

Installation and Maintenance Instructions

Gas fired condensing combi boiler

Greenstar 8000 Style

GR8700iW 30 C | GR8700iW 35 C | GR8700iW 40 C | GR8700iW 45 C | GR8700iW 50 C |
GR8700iW 30 CB | GR8700iW 35 CB | GR8700iW 40 CB | GR8700iW 45 CB | GR8700iW 50 CB



Table of contents

1	Explanation of symbols and safety instructions	4	5.5.1	Installer connections	42
1.1	Explanation of symbols	4	5.5.2	Cable preparations	43
1.2	General safety instructions	4	5.5.3	External controls - domestic installations	44
2	Regulations	6	6	Commissioning	44
3	Product Information	7	6.1	Pre-Commissioning checks	44
3.1	About the appliance	7	6.2	Water treatment	44
3.2	Scope of delivery	8	6.2.1	Filling the appliance and adding Inhibitor	45
3.3	Declaration of Conformity	8	6.2.2	Adjusting the operating pressure of the heating system	46
3.4	Appliance type overview	8	6.3	Starting the appliance	46
3.5	Product identification	8	6.3.1	Control panel overview	46
3.6	Pipework positions and flue outlet	9	6.3.2	Turn on the appliance	46
3.7	Product overview	10	6.3.3	Siphon filling mode	46
3.8	Product data for energy consumption	11	6.4	Chimney sweep mode	47
4	Pre-Installation	12	6.5	Combustion casing removal	47
4.1	System preparation	12	6.6	Checking gas inlet pressure	47
4.1.1	Artificially softened water	12	6.6.1	Checking the gas supply pressure	47
4.1.2	Water systems and pipework	12	6.7	Checking the gas rate	49
4.1.3	System layouts examples	13	6.8	Checking for gas leaks during operation	49
4.1.4	System fill	13	6.9	CO and combustion check	49
4.2	Mains supply	14	6.10	Checking flue integrity	51
4.2.1	Electrical supply	14	6.11	Flue gas analysis	51
4.2.2	Gas supply	14	6.12	Range rating the appliance	51
4.2.3	Water supply	15	6.13	Finishing commissioning	52
4.3	Appliance location and clearances	15	6.13.1	Fitting the appliance casing	52
4.3.1	Appliance location	15	6.13.2	Appliance/product guarantee	53
4.3.2	Rooms containing a bath or shower	16	7	Settings in the service menu	53
4.3.3	Appliance clearances	16	7.1	Operating the service menu	53
4.4	Flue systems considerations	17	7.2	Service menu	54
4.4.1	Flue length	18	7.2.1	Overview of the service menu	54
4.4.2	Flue options	18	7.2.2	Benchmark and Info menu	56
4.4.3	Plume management system	20	7.2.3	Settings menu	57
4.4.4	Flue terminal positions	22	7.2.4	Function check menu	60
4.4.5	Plume re-direct and plume management terminal positions	26	7.2.5	Reset menu	60
4.5	Condensate discharge	27	8	Inspection and maintenance	60
4.5.1	Appliance siphonic condensate trap	28	8.1	Inspection and maintenance considerations	61
4.5.2	Condensate pipework	28	8.2	Resources for inspection and maintenance	61
4.5.3	Internal connections	28	8.3	Inspection and maintenance steps	61
4.5.4	External connections	29	8.4	Component access	61
4.6	Pressure relief discharge	32	8.5	Fan pressure test	62
4.6.1	Pressure relief pipework	32	8.6	Check working gas inlet pressure	62
4.6.2	Alternative PRV connections - Combined PRV/condensate	32	8.7	Flue gas analysis	63
4.7	Cleaning primary systems	33	8.8	Checking the flue integrity	63
4.7.1	Flushing the system	33	8.9	Cleaning the siphon and heat exchanger	63
5	Installation	34	8.9.1	Checking the burner	63
5.1	Position the appliance	36	8.9.2	Checking the non-return valve in the air-gas manifold	64
5.1.1	Mounting frame fixing	36	8.9.3	Fan removal	65
5.2	Appliance connections	37	8.9.4	Cleaning the heat exchanger	65
5.3	Hanging the appliance	38	8.9.5	Checking electrodes	67
5.4	Flue turret/adaptor installation	40	8.9.6	Cleaning the siphon	67
5.5	Electrical connection	41	8.10	Setting the air/gas ratio	68
			8.10.1	Checking and, if required, adjusting the gas/air ratio	68

9	Replacement parts	70
9.1	Draining the appliance	70
9.2	Overheat thermostat removal	70
9.3	Pressure sensor removal	70
9.4	Pressure relief valve removal	71
9.5	Replacing the gas valve	71
9.6	Checking the strainer in the cold water pipe and the flow turbine.	72
9.7	Checking/replacing the motor of the 3-way valve.	72
9.8	Replacing the 3-way valve	72
9.9	Replacing the plate heat exchanger	73
9.10	Following inspection/maintenance	73
10	Fault finding and diagnosis	73
10.1	Operating and fault displays	73
10.1.1	General information	73
10.1.2	Fault code table	74
10.1.3	Faults that are not displayed	80
11	Environmental protection and disposal	82
12	Technical Specifications/Logs	83
12.1	Technical data	83
12.1.1	Specifications Combi	83
12.2	Ionisation current	86
12.3	Component resistance characteristics	87
12.3.1	Sensor values	87
12.4	Code plug	87
12.5	Pump characteristic map of the heating pump.	87
12.6	Limiting nominal heat output (range rating) (Settings menu, Heating, Max. heat output)	88
12.7	Electrical wiring	90
12.8	Gas Boiler System Commissioning Checklist and Warranty Validation Record	92
12.9	Inspection and maintenance checklist	93
12.10	Service and Interim Boiler Work Record	94

1 Explanation of symbols and safety instructions

1.1 Explanation of symbols

Warnings

In warnings, signal words at the beginning of a warning are used to indicate the type and seriousness of the ensuing risk if measures for minimizing danger are not taken.

The following signal words are defined and can be used in this document:

DANGER
DANGER indicates that severe or life-threatening personal injury will occur.

WARNING
WARNING indicates that severe to life-threatening personal injury may occur.

CAUTION
CAUTION indicates that minor to medium personal injury may occur.

NOTICE
NOTICE indicates that material damage may occur.

Important information

i
 The info symbol indicates important information where there is no risk to people or property.

Additional symbols

Symbol	Meaning
▶	a step in an action sequence
→	a reference to a related part in the document
•	a list entry
–	a list entry (second level)

Table 1

1.2 General safety instructions

Please read these instructions carefully before starting installation.

- These instructions are applicable to the Worcester appliance model(s) stated on the front cover of this manual only and must not be used with any other make or model of appliance.
- These instructions apply in the UK and Ireland only and must be followed except for any statutory obligations.
- This appliance must be installed by a competent registered gas engineer, such as a **Gas Safe** registered engineer including a **British Gas** engineer. Failure to install correctly could lead to prosecution.

- If you are in any doubt, contact the Worcester, Bosch Group help line (0330 123 3366).
- Distance learning and training courses are available from Worcester.
- The BENCHMARK Commissioning Checklist can be found on page 92 of this Installation manual.

Notices for the target group

These installation instructions are intended for gas, plumbing, heating and electrical contractors. All instructions must be observed. Failure to comply with instructions may result in material damage and personal injury, including danger to life.

- ▶ Read the installation, service and commissioning instructions (heat source, heating controller, pumps, etc.) before installation.
- ▶ Observe the safety instructions and warnings.
- ▶ Follow national and regional regulations, technical regulations and guidelines.
- ▶ Record all work carried out.

Intended use

The appliance may only be used for heating water or domestic hot water in domestic properties.

- ▶ Observe the details on the data plate and the specifications (installation manual) to ensure correct use of this appliance.
- ▶ Worcester Bosch offer flue gas systems which are suitable for use with the appliance. It is the responsibility of the installer of the flue to ensure this flue gas system operates correctly and in a safe manner.

If you smell gas

A gas leak could potentially cause an explosion. If you smell gas, observe the following rules:

- ▶ Prevent flames or sparks:
 - Do not smoke, use a lighter or strike matches.
 - Do not operate any electrical switches or unplug any equipment.
 - Do not use the telephone or ring doorbells.
- ▶ Turn off the gas at the meter or regulator.
- ▶ Open windows and doors.
- ▶ Warn your neighbours and leave the building.
- ▶ Prevent anyone from entering the building.
- ▶ Move well away from the building: call the National Gas Emergency Service on 0800 111 999.
- ▶ L.P.G. boilers: Call the supplier's number on the side of the gas tank.

⚠ Risk to life from carbon monoxide poisoning.

There is a risk to life from escaping flue gases

- ▶ Do not modify the flue gas system.
- ▶ Ensure that flue pipes and gaskets are undamaged.

If flue pipes are damaged or leaking:

- ▶ Turn off and isolate the appliance.
- ▶ Open windows and doors.
- ▶ If necessary, leave the building and warn your neighbours.
- ▶ Prevent anyone from entering the building.
- ▶ Rectify any damage to the flue system immediately.

⚠ Installation and maintenance

Installation and maintenance must only be carried out by a competent registered gas engineer, such as a Gas Safe registered engineer or British Gas engineer.

- ▶ Carry out a gas tightness test after completing work on gas-carrying components.
- ▶ Only use original spares.

⚠ Electrical work

Electrical work must only be carried out by a qualified electrician:

- ▶ Before starting electrical work;
 - Ensure that the electricity supply is safely isolated and secured to prevent inadvertent re-connection.
 Information on safe isolation can be found in the Health and Safety Executive guidance HSG85.
- Using test equipment approved to GS38 to confirm that the electricity supply is disconnected.
- ▶ Refer to the manufacturer's information when installing non Worcester components and systems to the Worcester appliance.

⚠ Handover to the user

When handing over, instruct the user how to operate the heating system and inform the user about its operating conditions.

- ▶ Explain how to operate the heating system and draw the user's attention to any safety relevant action.
- ▶ In particular:
 - Advise that alterations, servicing and repairs must only be carried out by a competent, registered gas engineer, such as a Gas Safe registered engineer or British Gas engineer.
 - Advise the user to have the appliance and system serviced annually to help ensure economy, safety and reliability.

- ▶ Point out the possible consequences (including personal injury, danger to life and material damage) of improper or inadequate inspection, cleaning and maintenance.
- ▶ Point out the dangers of carbon monoxide (CO) and recommend the use of CO detectors.
- ▶ Leave the installation instructions with the completed Benchmark Checklist (or a certificate confirming compliance with IS 813, Eire only) and the operating instructions with the user or at the gas meter.

⚠ Servicing

Advise the user to have the appliance and heating system thoroughly serviced annually by a competent, registered gas engineer, such as a Gas Safe registered engineer or British Gas engineer.

In the Republic of Ireland servicing work must be carried out by a Registered Gas Installer (RGI).

Approved spares must be used to help maintain the efficiency, safety and reliability of the appliance.

⚠ Benchmark Service Record

The service engineer must complete the Benchmark Service Record at the back of this manual after each service.



Benchmark places responsibilities on both manufacturers and installers.

The purpose is to ensure that customers are provided with the correct equipment for their needs, that it is installed, commissioned and serviced in accordance with the manufacturer's instructions by competent persons and that it meets the requirements of the appropriate Building Regulations. The Benchmark Checklist can be used to demonstrate compliance with Building Regulations and should be provided to the customer for future reference.

Installers are required to carry out installation, commissioning and servicing work in accordance with the Benchmark Code of Practice which is available from the Heating and Hot water Industry Council who manage and promote the scheme.

Visit hhic.org.uk for more information.

⚠ Health and safety

The appliance contains no asbestos and no substances have been used in the construction process that contravene the COSHH Regulations (Control of Substances Hazardous to Health Regulations 1988).

⚠ Combustion and corrosive materials

Do not store or use any combustible materials (paper, thinners, paints etc.) inside or within the vicinity of the appliance.

Chemically aggressive substances can corrode the appliance and invalidate any warranty.

⚠ Fitting and modification

Fitting the appliance and any controls to the appliance may only be carried out by a competent engineer in accordance with the current Gas Safety (Installation and Use) Regulations.

Flue systems must not be modified in any way other than as described in the fitting instructions. Any misuse or unauthorised modifications to the appliance, flue or associated components and systems could invalidate the warranty. The manufacturer accepts no liability arising from any such actions, excluding statutory rights.

⚠ General manual handling guidelines

- ▶ Only remove packaging at the time of the final installation.
- ▶ Always use Health and Safety guidance for manual handling of an appliance.
 - Never lift or carry more than the safe guidance limit on your own.
 - Always use appropriate methods and equipment when lifting/carrying an appliance.
- ▶ Never lift or carry packages by the shipping straps.
- ▶ During handling and unpacking, wear safety gloves to prevent injuries to your hands.
- ▶ Dispose of packing materials appropriately.

⚠ Important handling instructions

Care should be taken when transporting, lifting and carrying the appliance.

- ▶ Use a means of transport suitable for handling appliances (e.g. sack truck with strap, stair climbing or step trolley).
- ▶ When handling appliances, secure them against a fall.
- ▶ Let only trained personnel undertake the handling.
- ▶ The correct method for handling heavy objects should be strictly observed, at all times.

2 Regulations

Installation regulations

Current Gas Safety (Installation and Use) Regulations:

All gas appliances must be installed by a competent, registered gas engineer, such as a Gas Safe registered engineer or British Gas engineer in accordance with the current regulations.

Failure to install appliances correctly could lead to prosecution.

The appliance must be installed in accordance with, and comply to, the current:

- ▶ Gas Safety Regulations
- ▶ IET Regulations
- ▶ Building Regulations (England)
- ▶ Building Regulations (Wales)
- ▶ Building Standards (Scotland) (Consolidation)
- ▶ S.I. No. 183 and 292 - Energy Performance of Buildings Regulations (Ireland; current version)
- ▶ Health and Safety Document 635 (The Electricity at Work Regulations 1989) and any other local requirements
- ▶ EU Regulations No. 811/2013 - Energy Labelling

Building Regulations Part L1A (Current version) - new dwellings

If the installation is in a new build property or it is a first time installation in an existing property, the heating systems must conform to current building regulations Part L1A.

The exception to this are single storey, open plan dwellings where the living area is more than 70% of the total usable floor area. Then this type of dwelling can be controlled as one zone.

An alternative would be individual electronically controlled TRVs.

For dwellings with a floor area over 150m², separate time and temperature control for each zone is required. It is best practice to fit Thermostatic Radiator Valves (TRV's) to all radiators except the area where the room thermostat is sited.

Building Regulations Part L1B (Current version) - existing dwellings

For appliance replacements on an existing system, it is not necessary to zone the upstairs and downstairs separately, compliance with the zone requirements can be achieved by a single room thermostat or programmable room thermostat.

While the system is drained down, it is best practice to fit Thermostatic Radiator Valves (TRV's) to all radiators except the area where the room thermostat is sited.

British Standards

Where no specific instruction is given, reference should be made to the relevant British Standard codes of Practice.

- BS7074:1
 - Code of practice for domestic and hot water supply
- BS6891
 - Installation of low pressure gas pipework up to 28mm (R1)
- BS5546
 - Installation of gas hot water supplies for domestic purposes
- EN12828
 - Central heating for domestic premises
- BS5440:1
 - Flues and ventilation for gas appliances of rated heating not exceeding 70kW (net): Flues
- BS5440:2
 - Flues and ventilation for gas appliances of rated heating not exceeding 70kW (net): Air Supply
- BS7593
 - Treatment of water in domestic hot water central heating systems
- BS6798
 - Installation of gas fired boilers of rated input up to 70kW (net)
- BS7671
 - IET Wiring Regulations

Irish Standards

The current relevant Irish standards should be followed, including:

- ECTI
 - National rules for electrical installations
- IS 813
 - Domestic Gas Installations

LPG Installations

An appliance using LPG must not be installed in a room or internal space below ground level unless one side of the building is open to the ground.

Timber framed buildings

Where the appliance is to be fitted to a timber framed building the guidelines laid down in BS5440: Part 1 and IGE "Gas Installations in Timber Frame Buildings" should be adhered to.

Water supply:

All seals joints and compounds (including flux and solder) and components used as part of the secondary domestic water system must meet the requirements of the WRC and hold approval by a notified body, e.g. WRAS. The installation must also comply with the requirements of Part G of the Building Regulations.

CH Water

Salt based artificially softened water must not be used to fill the central heating system.

3 Product Information

3.1 About the appliance

The boiler has the following features:

- Pre-wired and pre-plumbed
- Galvanised steel inner frame
- Digital control system
- Automatic ignition
- Direct burner ignition electrodes
- Built-in frost protection
- Built-in fault finding diagnostics
- Automatic gas valve
- Modulating combustion air fan with speed regulator
- CH temperature sensor & control
- Pump anti-seizure protection
- Flue gas temperature sensor
- Condensate siphonic trap
- Plate type DHW heat exchanger
- Low Energy Modulating pump
- Range rated (the ability to change the maximum power output to suit the heat demand of the building)

Misuse

Appliance must be used as per the intended use statement. Operation outside the parameters of the intended use is considered misuse and could cause harm to people and damage to property.

Accessories should be as per accessories list. Minimum operational parameters are included in this document.

Using the appliance outside of its intended use may also invalidate the manufacturer's guarantee.

3.2 Scope of delivery

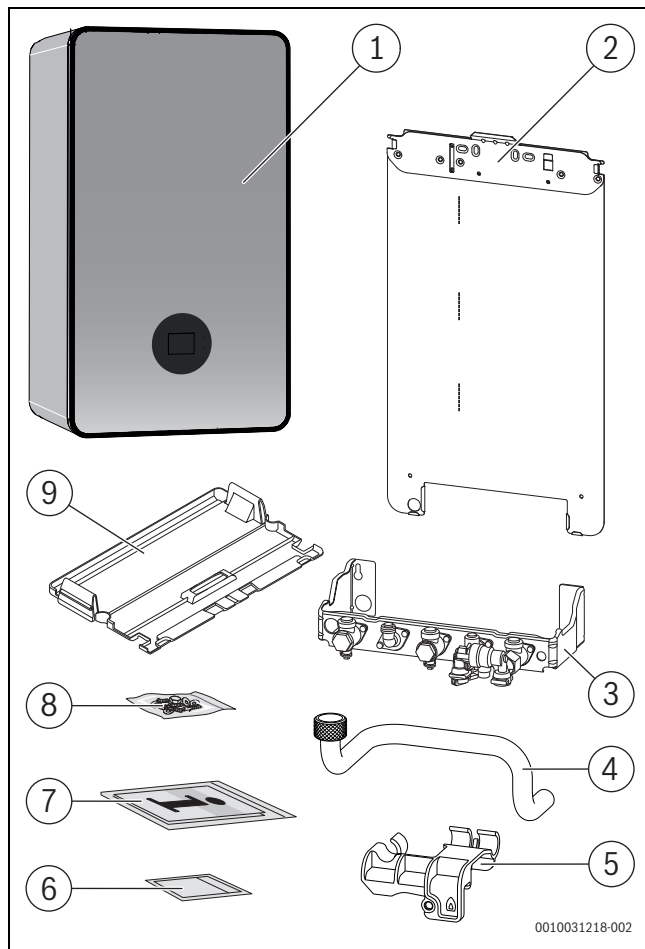

Fig. 1 Scope of delivery

- [1] Wall mounted gas condensing boiler
- [2] Mounting bracket
- [3] Mounting plate with Keyless Filling Link pre-installed
- [4] PRV discharge pipe
- [5] Mounting bracket
- [6] Guarantee card
- [7] Set of printed documents for product documentation
- [8] Fixing materials
- [9] Lower cover

3.3 Declaration of Conformity

The design and operation of this product comply with European Directives and the supplementary national requirements. Conformity has been demonstrated by the CE marking.

You can ask for a copy of the declaration of conformity for this product. For this see the contact address on the back cover of these instructions.

3.4 Appliance type overview

This appliance are for use with:

- Natural Gas or LPG (Cat.II 2H3P type C13, C33 & C53)

This document refers to the following appliance types:

Appliance type	Part number	Gas Council number
GR8700iW 30 C NG	7 738 100 795	47-800-03
GR8700iW 35 C NG	7 738 100 796	47-800-02
GR8700iW 40 C NG	7 738 100 797	47-800-01
GR8700iW 45 C NG	7 738 100 798	47-406-99
GR8700iW 50 C NG	7 738 100 799	47-406-98
GR8700iW 30 CB NG	7 738 100 832	47-406-97
GR8700iW 35 CB NG	7 738 100 833	47-406-96
GR8700iW 40 CB NG	7 738 100 834	47-406-95
GR8700iW 45 CB NG	7 738 100 835	47-406-94
GR8700iW 50 CB NG	7 738 100 836	47-406-93
GR8700iW 30 C LPG	7 738 100 839	47-800-13
GR8700iW 35 C LPG	7 738 100 840	47-800-12
GR8700iW 40 C LPG	7 738 100 841	47-800-11
GR8700iW 45 C LPG	7 738 100 842	47-800-10
GR8700iW 50 C LPG	7 738 100 843	47-800-09
GR8700iW 30 CB LPG	7 738 100 844	47-800-08
GR8700iW 35 CB LPG	7 738 100 845	47-800-07
GR8700iW 40 CB LPG	7 738 100 846	47-800-06
GR8700iW 45 CB LPG	7 738 100 847	47-800-05
GR8700iW 50 CB LPG	7 738 100 848	47-800-04

Table 2 Type overview

The name of the appliance consists of the following parts:

- GR8700iW: Type name
- 30, 35, 40, 45 or 50: Hot water output in kW
- C: Combi appliance
- B: Black front panel
- NG: Gas type (Natural Gas)
- LPG: Gas type (Liquid Petroleum Gas)

3.5 Product identification

Data plate

The data plate includes the product performance information, approval data and serial number. The data plate location can be found in the product overview.

Additional type plate

The product name and the most important product data are shown on the additional data plate. The additional type plate can be found on the outside of the product in an easily accessible location.

3.6 Pipework positions and flue outlet

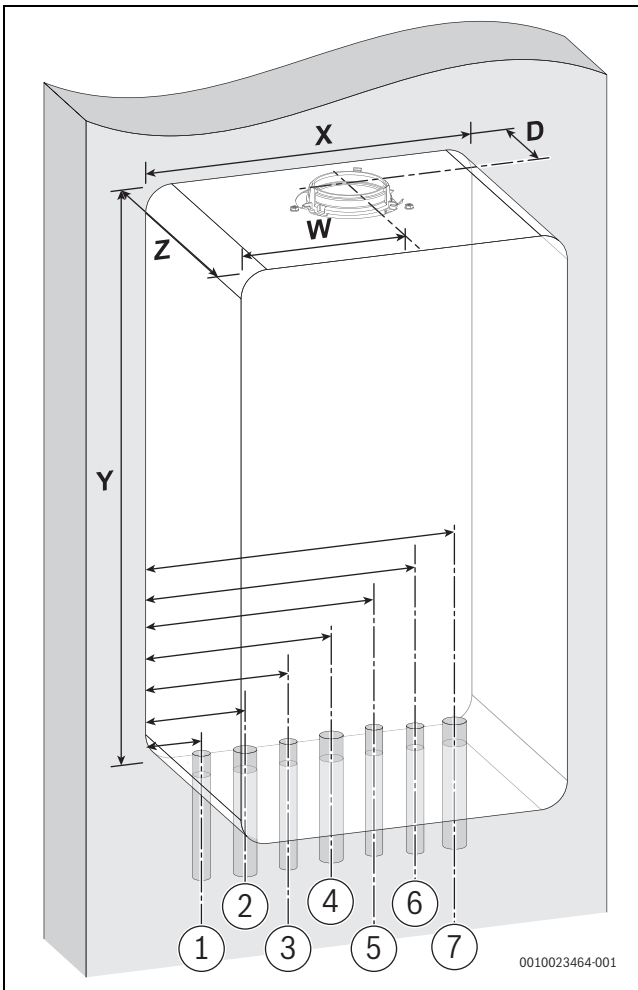

Fig. 2 Pipe and flue outlet dimensions

	Description	Dimensions [mm]
X	Appliance width	440
Y	Appliance height	780
Z	Appliance depth	365
W	Flue centre from appliance left side	220
D	Flue centre from rear of appliance	87

Table 3 Appliance and flue outlet dimensions

#	Function	From left case edge	Diameter of pipe
1	Condensate outlet	58mm	22mm • Rubber push fit connection
2	CH flow	90mm	22mm • Compression fitting
3	DHW outlet	155mm	15mm • Compression fitting
4	Gas inlet	220mm	22mm • Compression fitting
5	DCW inlet	285mm	15mm • Compression fitting
6	PRV discharge	314mm	15mm • Compression fitting
7	CH return	350mm	22mm • Compression fitting

Table 4 Pipe dimensions



For servicing purposes, keep condensate and pressure release valve discharge pipes away from other hydraulic components.

3.7 Product overview

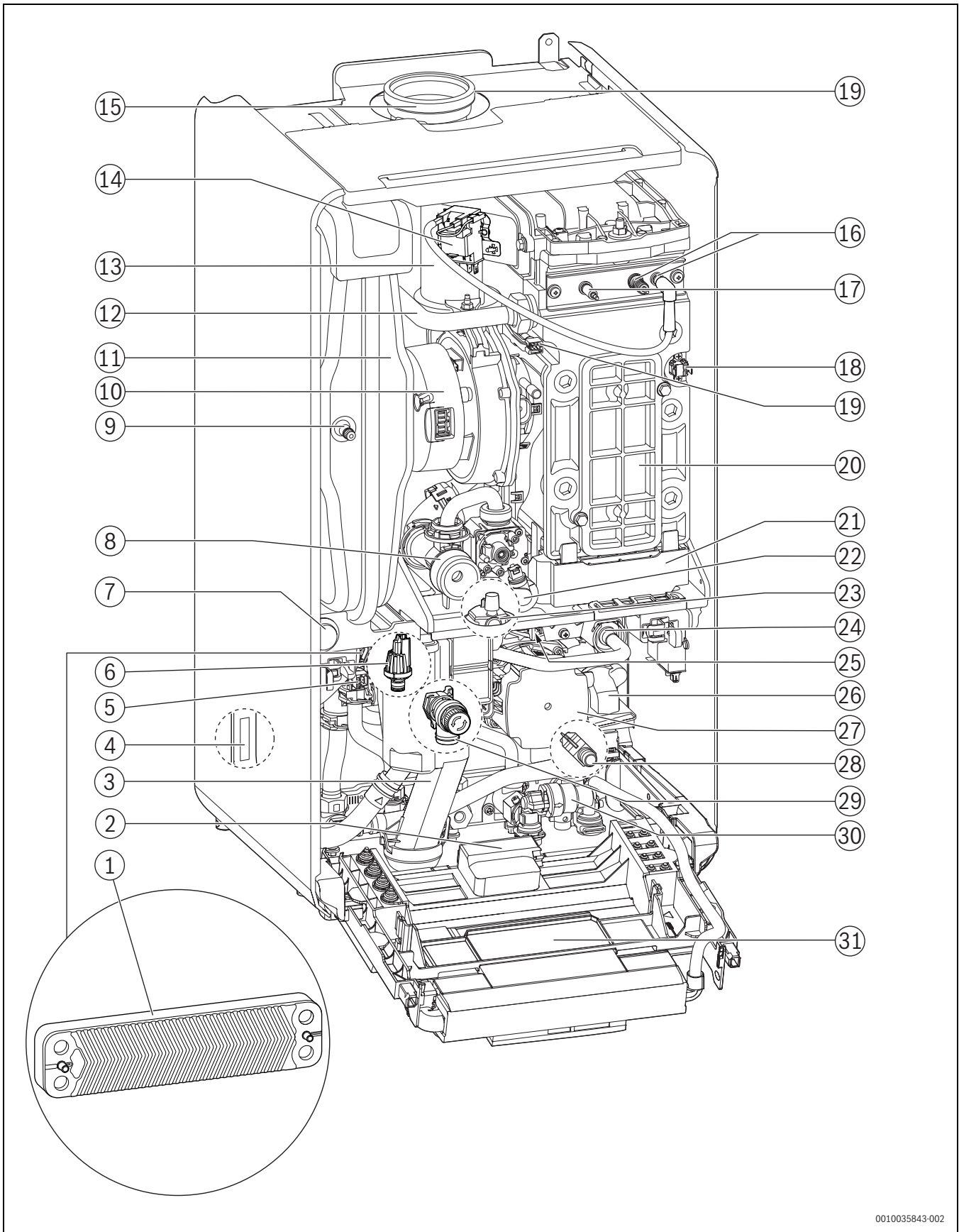

0010035843-002

Fig. 3 Product overview Combi boilers, combustion cover removed

- [1] Plate heat exchanger
- [2] Key accessory housing slot (wireless Gateway)
- [3] Condensate trap
- [4] Data plate 1
- [5] Hot water temperature sensor
- [6] Pressure sensor
- [7] Pressure gauge
- [8] Venturi (sealed)
- [9] Schrader Valve
- [10] Fan
- [11] Expansion vessel
- [12] Heating flow
- [13] Air-gas manifold with non-return valve
- [14] Ignition transformer
- [15] Flue
- [16] Ignition electrodes
- [17] Flame sensing electrode
- [18] Heating block temperature limiter
- [19] Flow temperature sensor at heating block
- [20] Inspection cover
- [21] Condensate sump
- [22] Gas valve
- [23] Automatic air vent valve
- [24] Flow turbine
- [25] Data plate 2
- [26] Diverter valve
- [27] Heating pump
- [28] Drain point
- [29] Pressure relief valve (heating circuit)
- [30] Filling Link
- [31] Control unit

3.8 Product data for energy consumption

The product data on energy consumption can be found in the operating instructions for the user.

4 Pre-Installation

NOTICE

Risk of damage to system or appliance!

Before installation

- ▶ All the following Pre-Installation sections must be read and requirements met before starting appliance or flue installations.

4.1 System preparation

4.1.1 Artificially softened water

The heating system must not be filled with water which has been treated using an ion exchange (salt based) water softener. Where these water softeners are installed, a permanent untreated water supply should be provided to maintain pressure in the heating system.

A bypass must be provided at the water softener to comply with BS:14743. Where a permanent untreated supply cannot be provided, the system must be initially filled using the bypass provided at the water softener. Occasional topping up of the system with artificially softened water is acceptable. Inhibitor must be added to the system. The pH levels must be between 6.5 and 8.0 at the time of commissioning. When a permanent untreated supply is not provided to the heating system filling point, the pH levels must be checked annually and recorded in the service record.

NOTICE

Risk of damage to appliance!

- ▶ The heating system must not be filled with water which has been treated using an ion exchange water softener.
- ▶ If the system is partially drained for maintenance or repair work, the system must be refilled by utilising the bypass valve at the water softener. The pH and inhibitor levels should be checked.

4.1.2 Water systems and pipework

Primary system plastic pipework:

- Any plastic pipework must have a polymeric barrier, complying with BS 7921 and installed to BS 5955 with 600mm (minimum) length of copper connected to the appliance.
- Plastic pipework used for under-floor heating must be correctly controlled with a thermostatic blending valve limiting the temperature of the circuits to approximately 50°C with 1000mm (minimum) length of copper or steel pipe connected to the appliance.

Primary system/connections/valves:

- Do not use galvanised pipes or radiators.
- All system connections, taps and mixing valves must be capable of sustaining a pressure of 3 bar.
- Radiator valves should conform to BS 2767:10.
- All other valves should conform to BS 1010.
- It is best practice to fit Thermostatic Radiator Valves (TRV's) to all radiators, except the area where the room thermostat is sited which must be fitted with lockshield valves that are left open.
- If the circulating pump speed is fixed and system circulation can be significantly adjusted or stopped by TRV's or zone valves, a system bypass should be installed to give at least a 3 metre circuit when activated. However; any appliance fitted with a modulating pump may not require a system bypass.
- Drain cocks are required at all the lowest points on the system.
- Air vents are required at all high points on the system.

Showers/Bidets:

- If a shower head can be immersed in water or comes closer than 25mm from the top edge of a bath or shower tray spill-over level then an anti-siphon device must be fitted to the shower hose.
- Bidets with direct hot and cold mains water can be used (with the approval of the local water authority) and must be the over rim flushing type with shrouded outlets to prevent the fitting of hand held sprays.

Hot water:

- Taps and mixing valves must be capable of sustaining a pressure up to 10 bar.
- Hot water temperature and flow rate are affected by the size and insulation of pipework making up the distribution system and are controlled by the hot water tap and the water main inlet pressure. A mixing valve can be fitted if a more permanent temperature setting is required.
- If using more than one outlet at once causes water flow starvation, fit flow balancing valves or Ball-O-Fix valves to the appropriate outlets.
- Thermostatic mixing valves (TMVs) must be fitted at the point of use as specified in G3 of the building regulations and if specific, accurate temperature control is required by the user.

Primary system considerations - Combi & System appliances

Sealed system

- The CH sealed system must be filled using a WRAS approved filling loop or comply with examples in section 4.1.4 "System fill".
- Where the system volume is more than 100 litres or exceeds 2.5 bar at maximum heating temperature an additional expansion vessel [2] must be fitted as close as possible to the appliance in the central heating return.
- Pressurise the extra expansion vessel [2] to the same value as the built-in expansion vessel [1] (default pre-charge pressure is 0.75 bar).

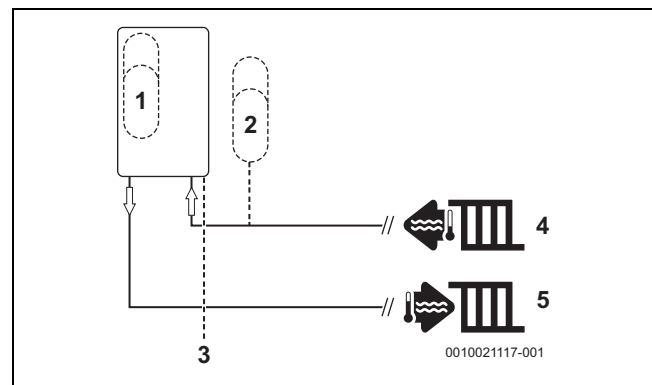

Fig. 4 Additional expansion vessel

- [1] Appliance expansion vessel
- [2] Additional expansion vessel
- [3] Pressure relief discharge
- [4] Heating return
- [5] Heating flow

Checking the size of the expansion vessel

To determine whether an additional expansion vessel is required: Follow the steps below:

- ▶ Calculate the total system volume (litres). Plotting a line vertically on the chart (→ Fig. 5).
- ▶ Determine the central heating maximum operating flow temperature (73 °C for condensing). Plot a line horizontally on the chart (→ Fig. 5).
- ▶ Determine the precharge in the expansion vessel based on static head, 1 metre = 0.1 bar (default = 10 metres).
- ▶ Select a curve from the key below (1-5).

If the dissected lines are in area A then no additional expansion is required.

If the dissected line is in are B then an additional expansion vessel must be installed (→ Fig. 4).

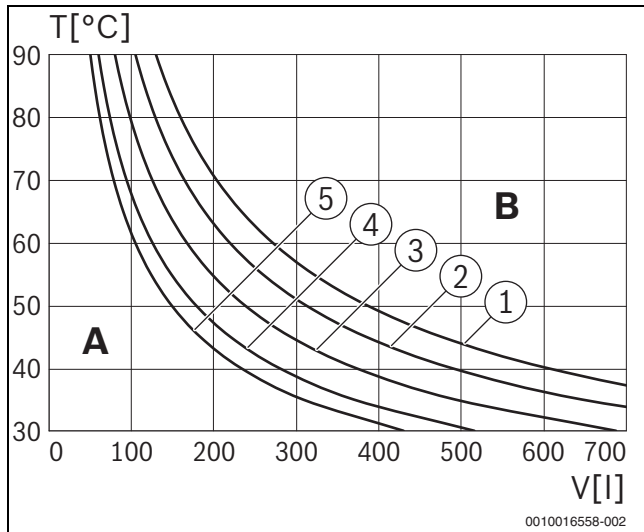

Fig. 5 Curves for the expansion vessel

- 1 Pre-charge pressure 0.5 bar (minimum)
- 2 Pre-charge pressure 0.75 bar (default setting)
- 3 Pre-charge pressure 1.0 bar
- 4 Pre-charge pressure 1.2 bar
- 5 Pre-charge pressure 1.3 bar
- T Maximum operating temperature [°C]
- V Total System Volume [l]

4.1.3 System layouts examples

Sealed primary system - Single central heating circuit:

Typical primary system example

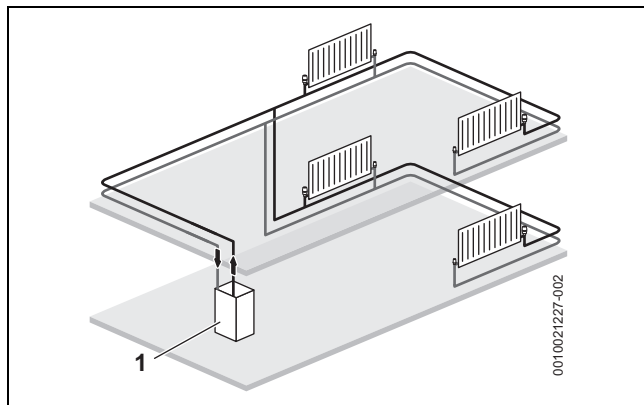

Fig. 6 Single central heating circuit example

- [1] Appliance

Sealed primary system - 2 x central heating zones:

- Requirement for new builds if the floor area of a property is over 150m².

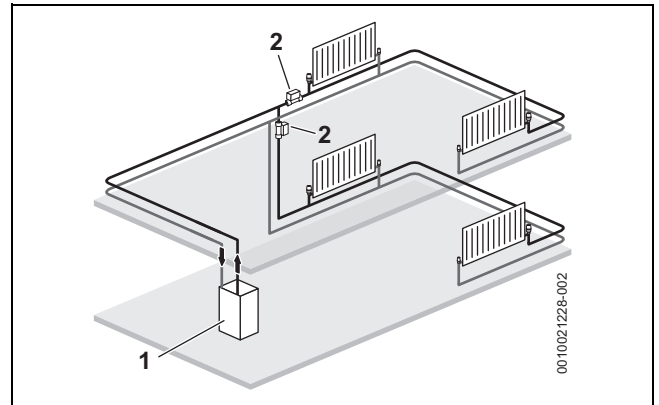

Fig. 7 Separated heating zones

- [1] Appliance
- [2] Zone valves

4.1.4 System fill

Filling primary sealed systems

NOTICE

Filling the primary sealed system

The system must not be filled with salt based softened water.

- ▶ Ensure the primary water filling point uses an untreated cold water connection from the mains supply, before a water softener.

- Filling the system must comply with one of the following methods shown.
- The filling point must be at low level and must never be a permanent connection to the mains water supply.
- Filling loops must be WRAS approved.
- If the external filling link is sited away from the appliance, then a pressure gauge should be installed at the filling point.



The pressure shown on the gauge may differ from that shown on the digital display. Final system pressure adjustments must be made whilst referencing the digital display.

Integral filling link

- An optional filling link accessory is available to fill the system (→ section "Integral keyless filling link", page 45).

External filling loop

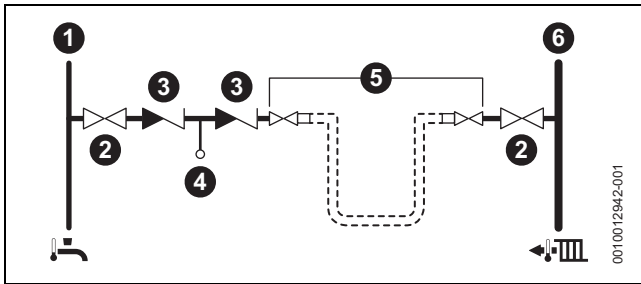

Fig. 8 External filling loop system fill example

- [1] Cold mains inlet pipe
- [2] Stop valve
- [3] Check valve
- [4] Test point
- [5] Hose union
- [6] Central heating flow pipe

4.2 Mains supply

4.2.1 Electrical supply

- Supply: 230V AC - 50 Hz
- This appliance must **not** be connected to a three phase supply.
- The wiring between the appliance and the electrical supply must comply with the latest IET wiring regulations that apply to wiring a fixed appliance for Class 1 equipment.
- The correct type of RCD must be employed where additional protection is required that is suitable for a low energy DC modulating pump according to IET wiring regulations.
- External 3A A fuse to BS1362.
- The appliance must be earthed.
- Cable: PVC insulated 0.75mm² (24 x 0.2mm) temperature rated to 90 °C, to BS EN50525.
- Any additional components that are connected to the appliance with mains electrical supply must not have a separate supply.
- Additional equipment wired to the appliance must comply with the latest IET wiring regulations.
- Appliance IP rating - IPX4D

4.2.2 Gas supply

- Appliances using Natural Gas (NG) must be connected to a governed meter.
- Appliances using Liquid Petroleum Gas (LPG) must be connected to a regulator.
- Installation and connection of the gas supply to the appliance must be in accordance with the latest version of BS6891.
- Gas pipe sizing should be calculated to ensure no more than the permitted mbar drop between the meter/governor to the appliance inlet (→ chapter 12.8).
- The meter or regulator and its pipework must be checked, preferably by the gas supplier. This is to ensure that the equipment is in good working order and can meet the gas flow and pressure requirements, in addition to the demand from any other appliance being served.

Pipe sizing (NG & LPG)



Gas pipework:

- ▶ Gas installation pipework must be designed to ensure the pressure loss between the meter outlet (NG) or storage and regulator (LPG) and the inlet to each appliance does not exceed 1mbar (NG) 2.5mbar (LPG) (→ table 16 "Allowed mbar pressure drop").

Basic pipe sizing calculation



Basic pipe sizing calculation.

- ▶ **This method is only an estimate - for more complex design please refer to latest version of BS6891 and training given in ACS.**

Natural Gas (NG):

Discharge rates for copper tube with 1mbar differential pressure between the ends for Natural Gas.

Discharge rates for Natural Gas (m ³ /hr) with straight horizontal copper tube					
Pipe length (m)	Discharge m ³ /hr	Pipe size (mm)			
		15	22	28	35
3		2.9	8.7	18	32
6		1.9	5.8	12	22
9		1.5	4.6	9.4	17
12		1.3	3.9	8	15
15		1.1	3.4	7	13
20		0.95	2.9	5.9	11
25		0.92	2.5	5.2	9.5
30		0.88	2.3	4.7	8.5

Table 5 Natural Gas (NG)



Natural Gas:

- ▶ When using this table to estimate the gas flow rate in pipework of a known length, the effective length will be increased by 0.5m for each 90° elbow and tee fitted and by 0.3m for each 45° bend.

Liquid Petroleum Gas (LPG):

Discharge rates for copper tube with 2.5mbar differential pressure between the ends for LPG.

Discharge rates for LPG (m ³ /hr & kW) with straight horizontal copper tube						
Tubing length (m)	Outside diameter					
	15mm		22mm		28mm	
	kW	m ³ /hr	kW	m ³ /hr	kW	m ³ /hr
3	38.4	1.49	207	8.01	412	15.92
6	26.1	1.01	135	5.21	230	8.86
9	20.5	0.79	108	4.19	215	8.33
12	17.9	0.70	94	3.62	187	7.25
15	15.5	0.60	82	3.20	168	6.51
18	13.5	0.53	74	2.86	145	5.61
21	12.9	0.50	67	2.58	135	5.24
24	12.0	0.47	61	2.58	126	4.87

Table 6 Liquid Petroleum Gas (LPG)



Liquid Petroleum Gas (LPG):

- ▶ When using this table to estimate the Gas flow rate in pipework of a known length, the effective length will be increased by 0.6m for each 90° elbow or tee and by 0.3m for each 45° bend or straight coupler.

4.2.3 Water supply

Water supply:

All seals joints and compounds (including flux and solder) and components used as part of the secondary domestic water system must meet the requirements of the WRC and hold approval by a notified body, e.g. WRAS. The installation must also comply with the requirements of Part G of the Building Regulations.

Use in hard water areas:

Normally there is no need for water treatment to prevent scale formation as the maximum temperature of the DHW heat exchanger is limited by the electronic control.

In areas where temporary water hardness exceeds 200ppm, consideration may need to be given to the fitting of a scale prevention device. In such circumstances, the advice of the local water authority should be sought.

Water mains pressure:

- Minimum mains water pressure, for maximum performance refer to section 12 "Technical Specifications/Logs".
- Maximum mains fed water static pressure is 10 bar. If necessary fit a pressure reducing valve.

NOTICE

Non-return, back flow prevention devices (including those associated with water meters) fitted to the mains water supply can cause a pressure build up which could damage the boiler and other household appliances.

NOTICE

Non-return valves in the cold water feed system.

If a non-return valve is fitted on the mains inlet, then pressure can increase significantly over normal standing pressure when the appliance carries out a DHW preheat or due to fast acting valves closing on other appliances/outlets.

- ▶ To ensure water pressure stays at a level that will not damage the boiler or other household appliances, we would recommend on installations where standing pressure exceeds 3bar, that a 3 bar pressure reducing valve and mini expansion vessel are fitted.
- Where the mains water supply has a non-return, back flow prevention valve fitted, a mini expansion vessel [3] should be connected to the mains water inlet pipe [1] between the non-return valve [2] and the appliance [4] as shown below.

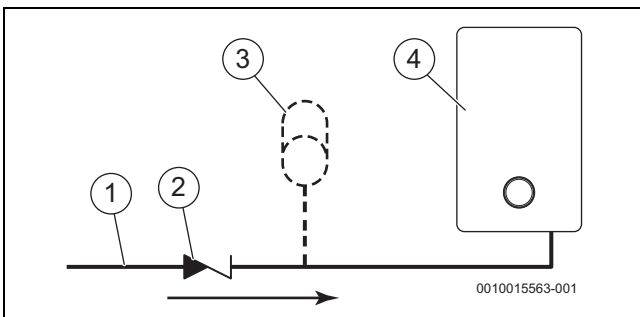

Fig. 9 Mini expansion vessel location

- [1] Mains water inlet pipe
- [2] Non-return valve
- [3] Mini expansion vessel - part no. 7 716 192 105
- [4] Appliance

4.3 Appliance location and clearances

4.3.1 Appliance location

- Follow local regulations for the location within the property that the appliance is to be installed.
- This appliance is only suitable for installing internally within a property at a suitable location onto a flat, fixed rigid surface capable of supporting the appliance weight.
- The appliance is not suitable for external installation.
- Protect installation area against dust and moisture.



No surface protection is required against heat transfer from the appliance.

! DANGER

Danger to life from explosion!

An increased and permanent ammonia concentration may lead to stress corrosion cracking on brass (e.g. gas valves, union nuts). As a result, there is a risk of explosion from gas escaping.

- ▶ Do not use wall mounted gas boilers in rooms where there is an increased or permanent ammoniac concentration (e.g. livestock stables or storage room for fertilisers).
- ▶ If contact with ammonia is unavoidable, make sure that there are no brass parts installed in the system.

! DANGER

Danger from explosive and flammable materials:

Storage of explosive and flammable materials.

- ▶ Do not store flammable materials (paper, curtains, clothing, primer, paint, ...) in proximity to the appliance.

NOTICE

Damage to appliance:

Contaminated combustion air.

- ▶ Do not use any cleaners containing chlorine or hydrogen halide (i.e. spray cans, primers, cleaners, paint and glue).
- ▶ Do not store or use these substances in the appliance or room.
- ▶ Avoid the build-up of dust.

NOTICE

Damage to appliance:

Extreme temperatures may cause damage to the heating system.

- ▶ Ensure the ambient temperature is above 0 °C and below 35 °C.

NOTICE

Damage to system:

The heating system pipework can be damaged by frost if installed in an internal unheated area, such as a loft, basement or garage.

The appliance internal frost protection only monitors the system water temperature within the appliance to provide protection for the appliance.

- ▶ Install a frost thermostat and pipe thermostat connected in series, to protect the system pipework. We recommend that the frost thermostat is sited in the coldest unheated area in which pipework is located and that it is set to call for

heat at 5 °C. The Pipe stat should be located on whichever pipe is furthest from the heated area where warmer water will be drawn from considering the direction of flow, and set to end the demand at 15 °C.

- ▶ The system pipework in the internal unheated area should be insulated.
- ▶ If the appliance is to be shut down for an extended period, drain the central heating system.



The appliance must be installed where:

- ▶ The area is well lit, allowing users to clearly see the appliance to carry out any work or checks.
- ▶ An engineer can gain clear and safe access to work on the product or component, including making adequate provision for visual inspection of flues in voids.
- ▶ The homeowner can gain clear and safe access to the controls or to check, top up or reset the appliance.
- ▶ Roof space installations must fully conform to BS 5410 part 1: roof space installations.
- ▶ Products in roof spaces must have permanent fixed lighting, a permanent fixed retractable ladder and a fixed floor area sufficient to allow access for normal use and servicing around the product and between the product and the access hatch.
We would also recommend that a remote pressure gauge and filling loop are sited where the customer can gain easy access to assist with checking and topping up.

4.3.2 Rooms containing a bath or shower



CAUTION

Risk of electric shock

- ▶ Any switch or appliance control using mains electricity must not be within reach of a person using the bath or shower.
- In all cases the installation **must be in accordance with the latest amendments to the latest edition of the IET Wiring Regulations (BS7671)**.
- Check the IP rating of any control units to be used on this appliance.
- Circuit breaking appliances should be used in accordance with the regulations.
- Figure 10 is for guidance only.

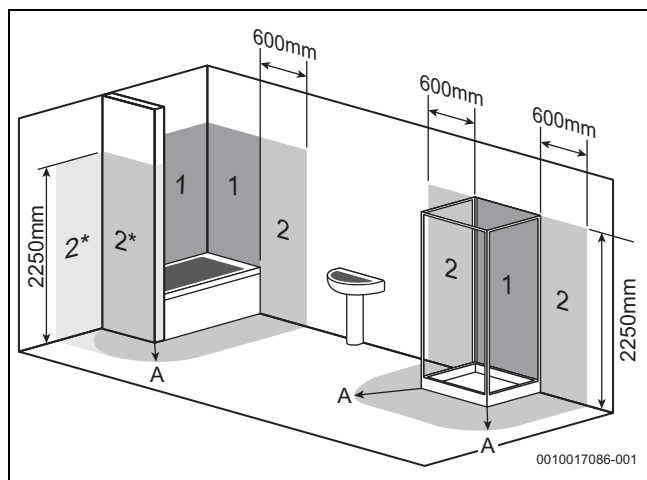

Fig. 10 Bathroom installations

- [1] Zone 1
- [2] Zone 2
- [2*] Without the end wall, zone 2 must extend 600mm from the bath
- [A] 600mm radius from the bath or shower

4.3.3 Appliance clearances

- The following details cover the installation, service and maintenance clearances for the appliance.



CAUTION

Risk of damage to appliance or property

The appliance will overheat if the clearance space around the appliance is restricted by objects.

- ▶ Do not restrict this space with the addition of cupboards, shelves etc. next to or around the appliance.
- ▶ Do not store any combustible materials on or next to the appliance, such as clothes, towels, paper or plastic bags.

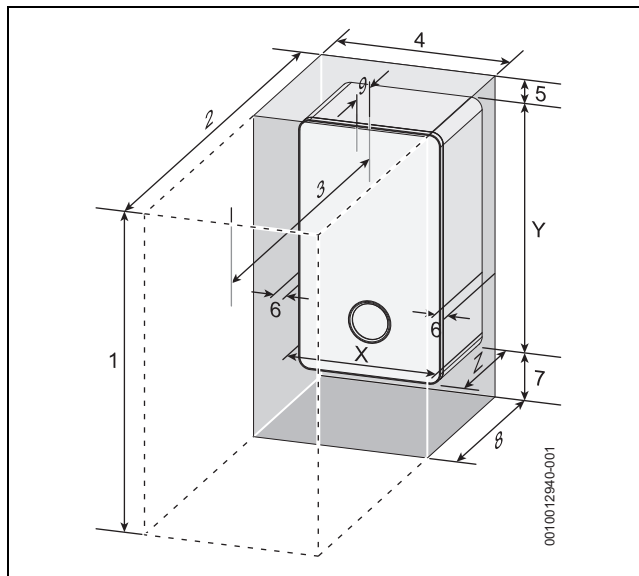

Fig. 11 Appliance minimum clearances

Minimum clearances		
Description		Dimensions [mm]
X	Appliance width	440
Y	Appliance height	780
Z	Appliance depth	365
Installation/Maintenance		
1	Overall clearance height	1,150/1,190*
2	Overall clearance depth	965
3	In front of appliance	450
4	Overall clearance width	450
5	Above the appliance	170/210*
6	Either side of appliance	5
7	Below the appliance	200
8	Compartment depth	385
9	Appliance to removable door	20

Table 7

[*] Height for either 60/100 flue or 80/125 flue

Reduced front maintenance minimum clearances

The front servicing clearance for this appliance can be reduced to 450mm.

For installations with a front servicing clearance less than 600mm (minimum of 450mm), the following additional criteria must be achieved.

- The bottom of the appliance case must be between 1000mm and 1500mm from the floor.
- There must be at least 450mm clearance in front of the appliance to floor level. Anything sited below the appliance must not protrude into this clear space.
- There must be at least 200mmmm clearance to any structure which is sited below the appliance.
- There must be at least 300mm clear space to either the left hand or right hand side of the appliance. This clear space must be from the required clear height above the appliance to floor level.
 - This clearance will not apply if the appliance is sited within 300mm of a door way and the door frame is the only obstruction.

i Minimum clearances must be observed to any obstruction/ surface, (dark shaded areas, figures 12 and 13).

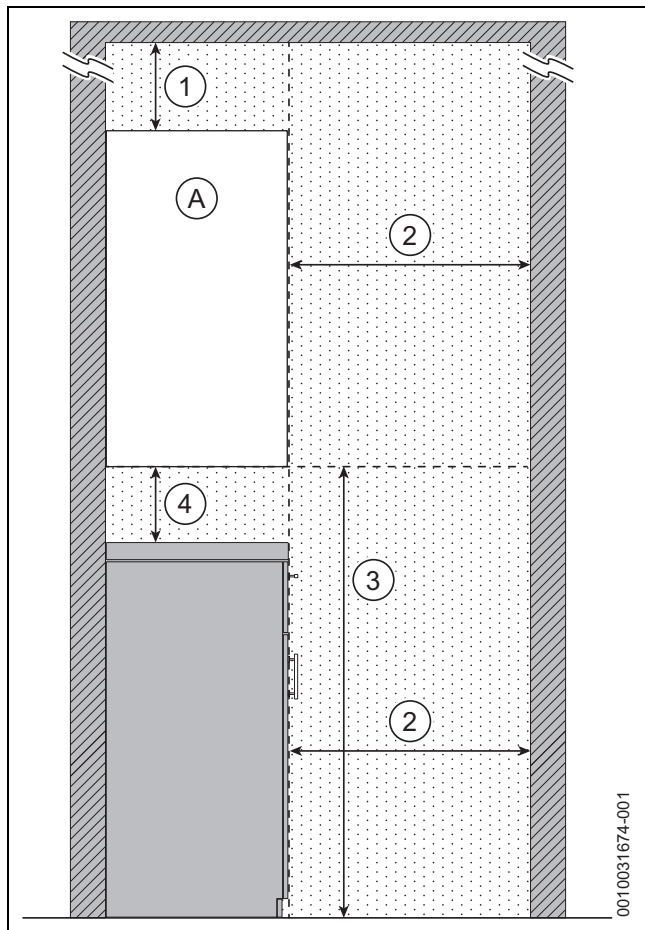

Fig. 12 Reduced front maintenance clearances - Side view

- [A] Appliance.
- [1] Above appliance - Same clearance required as for standard clearances of 60/100 flue or 80/125mm flue.
- [2] In front of appliance - Minimum 450mm.
- [3] Bottom of appliance to the floor - 1,000 - 1,500mm.
- [4] Below appliance - 200mmmm

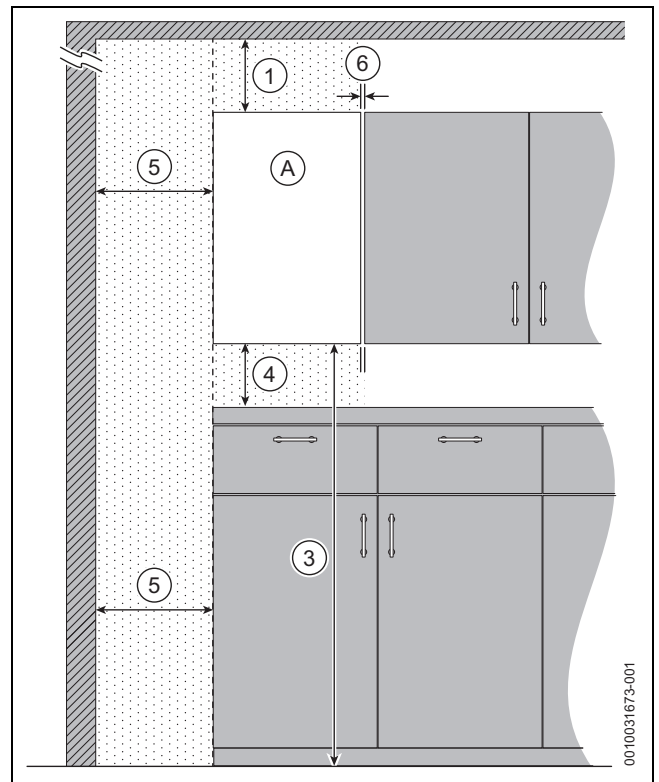

Fig. 13 Reduced front maintenance clearances - Front view

- [A] Appliance.
- [1] Above appliance - Same clearance required as for standard clearances of 60/100 flue or 80/125mm flue.
- [3] Bottom of appliance to the floor - 1,000 - 1,500mm.
- [4] Below appliance - 200mmmm
- [5] One side of appliance - Minimum 300mm.
- [6] One side of appliance - Minimum 5mm.

Appliances in compartments

Follow the latest requirements of BS6798 and BS5440 and note:

- Minimum clearances must be maintained.
- An access door is required to install, service and maintain the appliance and any ancillary equipment.
- If the appliance is installed in an unventilated airing/storage cupboard, there is no requirement to make a partition between the appliance and the storage space as long as the minimum clearances around the appliance are maintained.

4.4 Flue systems considerations

! WARNING

Flue systems

Possible flue gas escape

- ▶ Use Worcester, Bosch Group approved Condensfit II flue systems only, no other manufacturer's flue have been tested or approved for use with Worcester, Bosch Group appliances.





CAUTION

Concealed flue systems:

- ▶ Where a flue system is going to be concealed, provision must be made for service and inspection.
- ▶ Voids containing concealed flues must have at least one inspection hatch no less than 300mm square.
- ▶ Flue joints within the void must not be more than 1.5 metres from the edge of the inspection hatch.
- ▶ Inspection hatches should be located at changes of direction.
- ▶ If this is not possible, bends should be viewable from both directions.



Refer to the manual supplied with the Worcester, Bosch Group flue kit for complete installation instructions.

Flue kit part numbers

Part number	Flue Ø	Description
7 738 112 869	60/100	Telescopic horizontal flue kit (Silver)
7 716 191 082	60/100	Telescopic horizontal flue kit
7 716 191 171	60/100	Extended telescopic horizontal flue kit
7 733 600 048	60/100	Horizontal high level telescopic flue kit
7 719 003 702	80/125	Telescopic horizontal flue kit
7 719 002 430	60/100	Vertical balanced flue kit
7 719 002 431	80/125	Vertical balance flue kit

Table 8 Flue kit assembly part numbers

4.4.1 Flue length

The maximum flue length will depend on the following factors:

- 60/100mm flue system
 - Vertical/horizontal flue type
 - Appliance output
 - Plume management length
- 80/125mm flue system
 - Vertical/horizontal flue type
 - Appliance output

Horizontal maximum flue lengths

Output	Flue length [L] 60/100			Flue length [L] 80/125 No plume management available
	No plume management	+ 500mm of plume management	+ 4500mm of plume management	
50 kW	9,000mm	9,000mm	6,200mm	40,000mm
45 kW	8,000mm	8,000mm	5,200mm	35,000mm
40 kW	11,000mm	11,000mm	8,200mm	35,000mm
35 kW	10,000mm	10,000mm	7,200mm	29,000mm
30 kW	17,000mm	17,000mm	14,200mm	25,000mm

Table 9 Maximum flue lengths - Horizontal flues

Vertical maximum flue lengths

Output	Flue length [L]	
	60/100	80/125
50 kW	12,000mm	40,000mm
45 kW	12,000mm	35,000mm
40 kW	15,000mm	35,000mm
35 kW	14,000mm	29,000mm
30 kW	21,000mm	25,000mm

Table 10 Maximum flue lengths - Vertical flues

Flue system bends

NOTICE

Effective flue lengths of bends:

Each bend used has an equivalent straight flue length.

- ▶ Refer to table 11.

Bend	Effective flue length	
	60/100	80/125
45°	0.5m	0.5m
90°	1.5m	1.5m

Table 11 Effective length of bends

4.4.2 Flue options

The systems have different maximum flue lengths, refer to the following example flue options for those maximum flue lengths.

Horizontal high level flue assembly

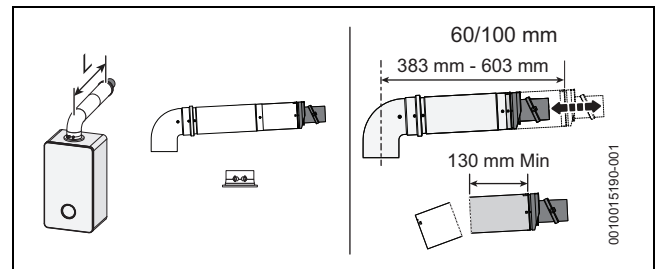

Fig. 14 Horizontal flue option

- Flue length [L] (initial bend included in length calculation)
 - 60/100 = 202 - 603mm
 - 80/125 = N/A

Telescopic horizontal flue assembly

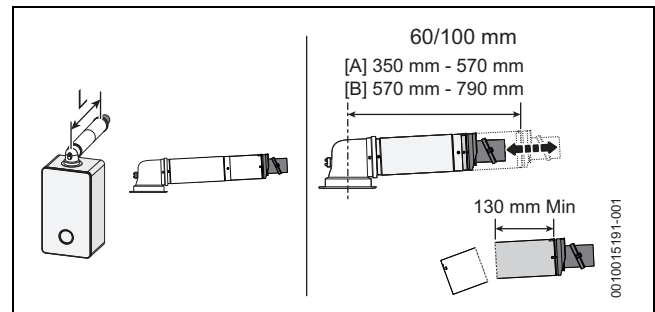

Fig. 15 Horizontal flue option

Telescopic horizontal flue assembly [A]

- Flue length [L] (adaptor bend included in length calculation)
 - 60/100 = 180 - 570mm
 - 80/125 = 405 - 600mm

Extended telescopic horizontal flue assembly [B]

- Flue length [L] (adaptor bend included in length calculation)
 - 60/100 = 570 - 790mm
 - 80/125 = N/A

Horizontal fixed length flue assembly

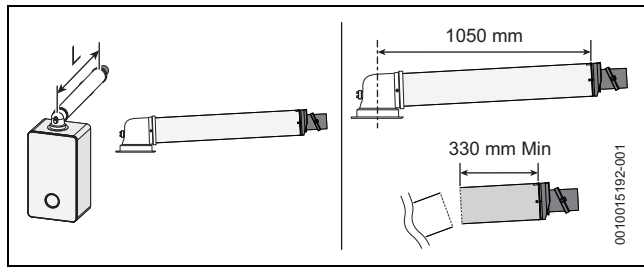

Fig. 16 Horizontal flue option

- Flue length [L] (adaptor bend included in length calculation)
 - 60/100 = 330 - 1,050mm
 - 80/125 = N/A

Extended horizontal flue

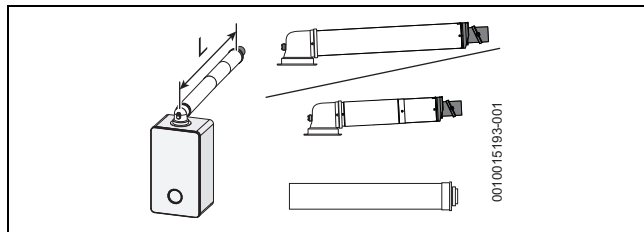

Fig. 17 Horizontal flue option

- Flue length [L] (adaptor bend included in length calculation)
 - Maximum flue length as stated in "Horizontal maximum flue lengths".

Horizontal flue with additional 90° elbow

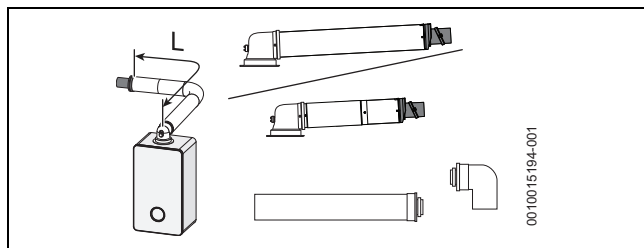

Fig. 18 Horizontal flue option

- Flue length [L] (adaptor bend included in length calculation)
 - Maximum flue length as stated in "Horizontal maximum flue lengths" minus the 90° bend equivalent straight flue length as stated in Table 11 "Effective length of bends".

Horizontal flue with additional 90° elbows

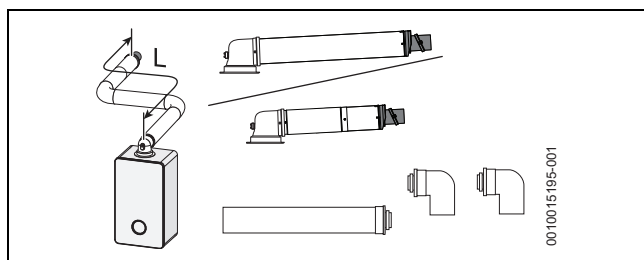

Fig. 19 Horizontal flue option

- Flue length [L] (adaptor bend included in length calculation)
 - Maximum flue length as stated in "Horizontal maximum flue lengths" minus 2 x 90° bends equivalent straight flue length as stated in Table 11 "Effective length of bends".

High level horizontal flue

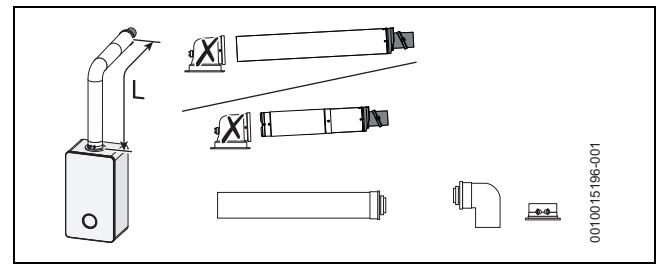

Fig. 20 Horizontal flue option

- Flue length [L] (initial bend included in length calculation)
 - Maximum flue length as stated in "Horizontal maximum flue lengths".

High level horizontal flue with additional 90° elbow

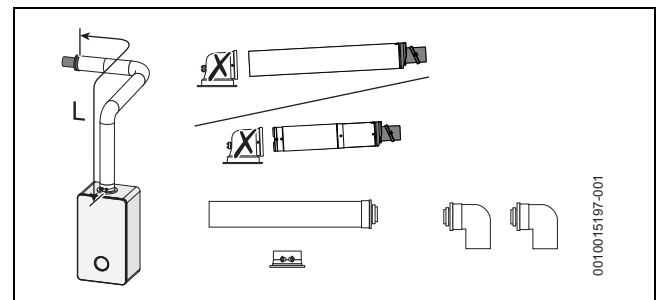

Fig. 21 Horizontal flue option

- Flue length [L] (initial bend included in length calculation)
 - Maximum flue length as stated in "Horizontal maximum flue lengths" minus the 90° bend equivalent straight flue length as stated in Table 11 "Effective length of bends".

High level horizontal flue with additional 90° elbows

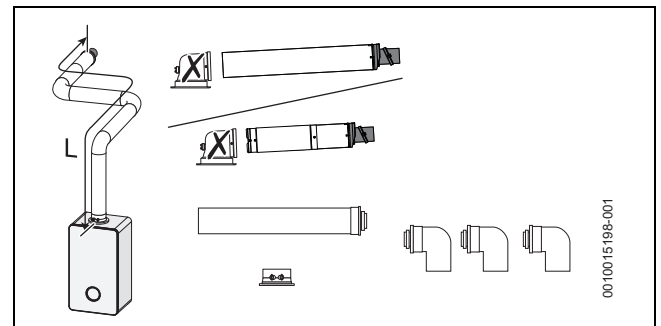

Fig. 22 Horizontal flue option

- Flue length [L] (initial bend included in length calculation)
 - Maximum flue length as stated in "Horizontal maximum flue lengths" minus 2 x 90° bends equivalent straight flue length as stated in Table 11 "Effective length of bends".

Vertical balanced flue assembly

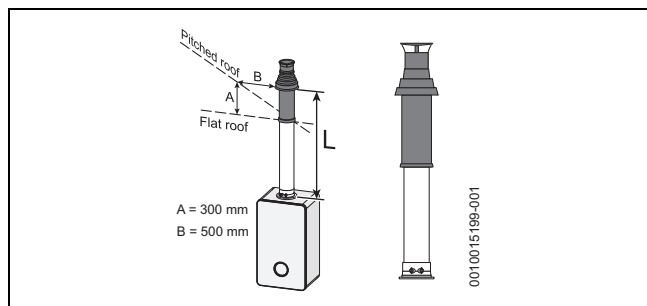

Fig. 23 Vertical flue option

- Flue length [L]
 - Maximum flue length as stated in "Vertical maximum flue lengths".

Vertical balanced flue with 90° elbow offset

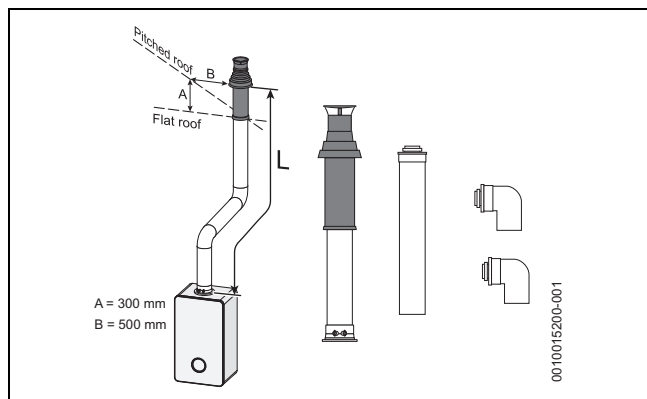

Fig. 24 Vertical flue option

- Flue length [L]
 - Maximum flue length as stated in "Vertical maximum flue lengths" minus 2 x 90° bends equivalent straight flue length as stated in Table 11 "Effective length of bends".

Vertical balanced flue with 45° elbow offset

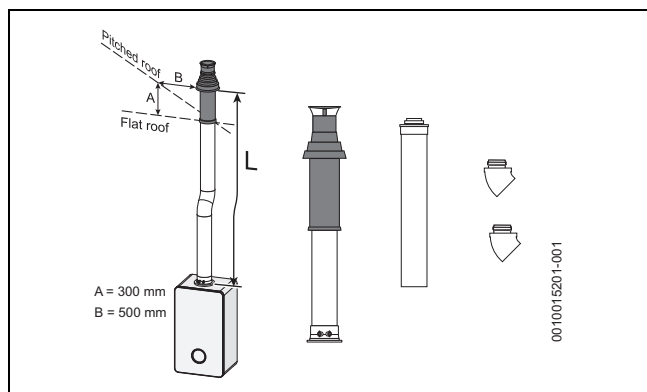

Fig. 25 Vertical flue option

- Flue length [L]
 - Maximum flue length as stated in "Vertical maximum flue lengths" minus 2 x 45° bends equivalent straight flue length as stated in Table 11 "Effective length of bends".

4.4.3 Plume management system

For every extra 1,000mm of plume management after the first 500mm, the internal 60/100 flue length must be reduced by 700mm, up to a maximum of 4,500mm of plume management.

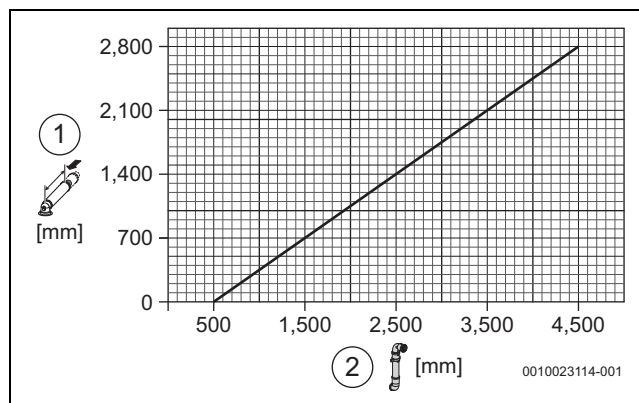

Fig. 26 Reduction to flue length as plume length increases graph

- [1] Reduction to flue length [mm] (maximum reduction 2,800mm)
- [2] Plume length [mm] (maximum plume length 4,500mm)

NOTICE

Plume management terminal:

- ▶ The plume management terminal must not be sited within 500mm of the air intake, and must not exceed the maximum straight length for a horizontal Ø 60/100mm flue with a 60mm plume management system.



Horizontal plume management runs

- ▶ The initial horizontal run from the terminal elbow must have a minimum 10° fall back, (stop tabs in the elbow prevent less than 10°) to the appliance for proper disposal of condensate.
- ▶ Any further horizontal runs after an elbow can be 3°.



WARNING

Minimum plume management length:

The minimum distance of 500mm must be maintained between air inlet and exhaust.

- ▶ Do not terminate the plume management inside the terminal exclusion zone (shaded area) shown in figure 27.

4.4.4 Flue terminal positions



CAUTION

Flue terminal positions

- ▶ All measurements are the minimum clearances required.
- ▶ Terminals must be positioned so to avoid combustion products entering the building.

Vertical flue terminal positions

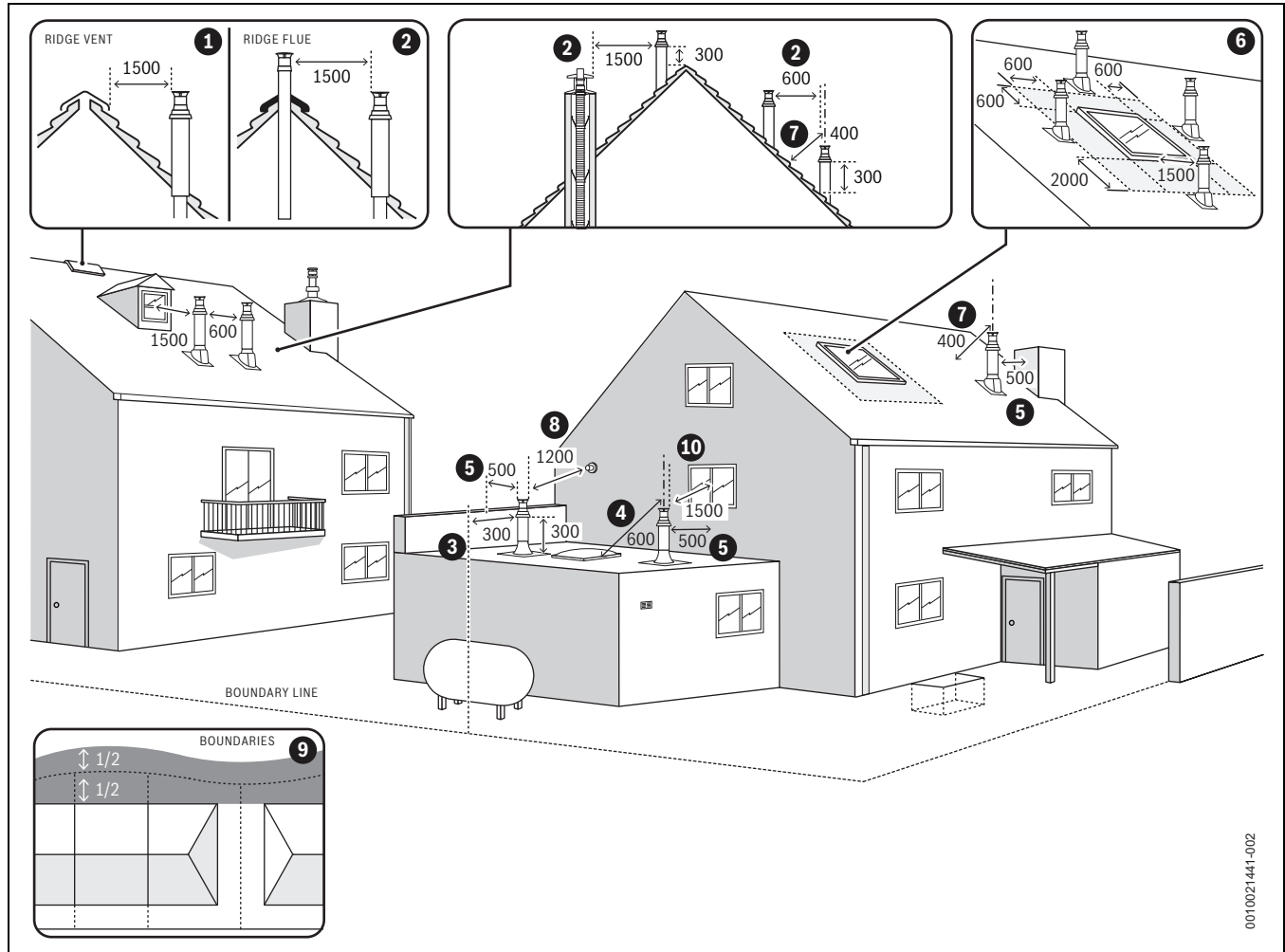

Fig. 28 Vertical flue terminal positions

0010021441-002

Key to figure 28:

- [1] 1,500mm measured between a vertical flue terminal and an opening or vented window. 500mm measured horizontally between a vertical flue terminal and an opening or vented window providing the flue terminal is at least 300mm above the opening.
- [2] Minimum clearance to an additional flue, 600mm to a room sealed flue or 1,500mm to an open flue.
- [3] 300mm clearance from a vertical flue terminal adjacent to a boundary line, unless it will cause a nuisance. BS 5440: Part 1 recommends that care is taken when siting a terminal in relation to boundary lines.
- [4] 600mm minimum clearance measured from an opening or vented skylight to a vertical flue terminal. If the terminal is within 1,500mm of the opening or vented skylight then it must be at least 300mm above the opening.
- [5] 500mm clearance measured horizontally from a vertical flue to a vertical structure.
Not required if the terminal is 300mm above the structure.
- [6] The flue must not penetrate the roof in the shaded area. The terminal must be at least 1,500mm from the opening or vent when sited below the window or 600mm when sited to either side or above.
- [7] 400mm measured diagonally from a pitched roof or 500mm in regions with heavy snow fall. 300mm measured vertically from the air intake to the closest intersection with the roof.
- [8] 1,200mm separation measured between a vertical flue and a horizontal flue terminal.
- [9] For the purpose of determining suitable flue terminal positions for gas appliances, the boundary can be considered to extend to the centre line of any adjacent routes or waterways e.g. paths, streets, rights of way, canals, rivers or railways.
- [10] 1,500mm measured between a vertical flue terminal and an opening or vented window. 500mm measured horizontally between a vertical flue terminal and an opening or vented window providing the flue terminal is at least 300mm above the opening.

Note:

- ▶ Where a vertical flue terminates in an area that is enclosed on 3 sides, the flue must be no more than 1,000mm below the lowest roof line. You must ensure that all clearances are maintained and that products of combustion disperse safely from the area.

Key to figure 29:

- [1] 200mm below eaves and 75mm below gutters, pipe and drains.
- [2] The dimension below eaves, gutters, pipes and drains can be reduced to 25mm, as long as the flue terminal is extended by 100mm past any overhang. The telescopic flue joint must be sealed with suitable silicone sealant if it is external to the building.
- [3] 300mm adjacent to a boundary line, unless it will cause a nuisance. BS 5440: Part 1 recommends that care is taken when siting terminal in relation to surfaces or boundary lines.
- [4] 1,200mm separation measured between terminals facing each other.
- [5] 600mm distance to a surface or boundary line facing a terminal, unless it will cause a nuisance. BS 5440: Part 1 recommends that care is taken when siting terminal in relation to surfaces or boundary lines.
- [6] The terminal must be at least 1,500mm from the opening or vent when sited below the window or 600mm when sited to either side or above.
- [7] 600mm diagonally to an opening door, air vent or opening window.
- [8] 1,200mm separation measured between a vertical flue and a horizontal flue terminal.
- [9] For the purpose of determining suitable flue terminal positions for gas appliances, the boundary can be considered to extend to the centre line of any adjacent routes or waterways e.g. paths, streets, rights of way, canals, rivers or railways.
- [10] 300mm to an internal or external corner. 300mm above a surface, such as the ground/ floor level or roof surface.
* If the terminal section is less than 150mm and has two screws securing it to the elbow, the terminal section will not require a supporting bracket.
- [11] 300mm above, below and either side of an opening door, air vent or opening window.
- [12] Below ground level in an open lightwell. The flue must be at least 600mm from the opposing surface and have at least 300mm clearance either side and below. The flue terminal must be no more than 1,000mm from the top of the lightwell.
- [13] Flues should clear any LPG storage by 1,000mm horizontally and 300mm above.
- [14] Proximity of flue duct outlet to boundaries, 2,000mm distance to an opening in adjacent building facing a terminal. BS 5440: Part 1 recommends that care is taken when siting terminal in relation to boundary lines.
- [15] 300mm from an opening or vented window, 150mm to a fixed unvented window.
- [16] The dimension below eaves, balconies and car ports can be reduced to 25mm, as long as the flue terminal is extended to clear any overhang. The telescopic flue joint of the terminal must be sealed with suitable silicon sealant if it is external to the building.
- [17] 300mm Horizontally from a terminal on the same wall.
- [18] 1500mm Vertically from a terminal on the same wall.

Note:

- ▶ Installations in car ports are not recommended.
- ▶ The flue cannot be lower than 1,000mm from the top of a light well due to the build up of combustion products.
- ▶ Dimensions from a flue terminal to a fanned air inlet to be determined by the ventilation equipment manufacturer.
- ▶ A flue terminal guard shall be fitted whenever a terminal or air inlet is fitted less than 2,000mm above ground, above a balcony or above a flat roof to which people have access.

4.4.5 Plume re-direct and plume management terminal positions



Maximum and minimum plume management lengths:

- ▶ A minimum distance of 500mm must be maintained between the plume management outlet and the flue air intake.
- ▶ The maximum plume management length is 4.5 metres for the appliances detailed on the front of this manual.
- ▶ The 45° bend is equivalent to 0.5 metres of straight plume management and the 90° bend is equivalent to 1.0 metres.

NOTICE

- ▶ All measurements are the minimum clearances required.
- ▶ Refer to “Horizontal flue terminal positions” for all concentric flue terminal positions unless the flue position is specified in figure 30 “Plume re-direct and plume management terminal positions”.
- ▶ Terminals must be positioned so to avoid combustion products entering the building.
- ▶ Support the flue at approximately one metre intervals and at a change of direction, use suitable brackets and fittings.

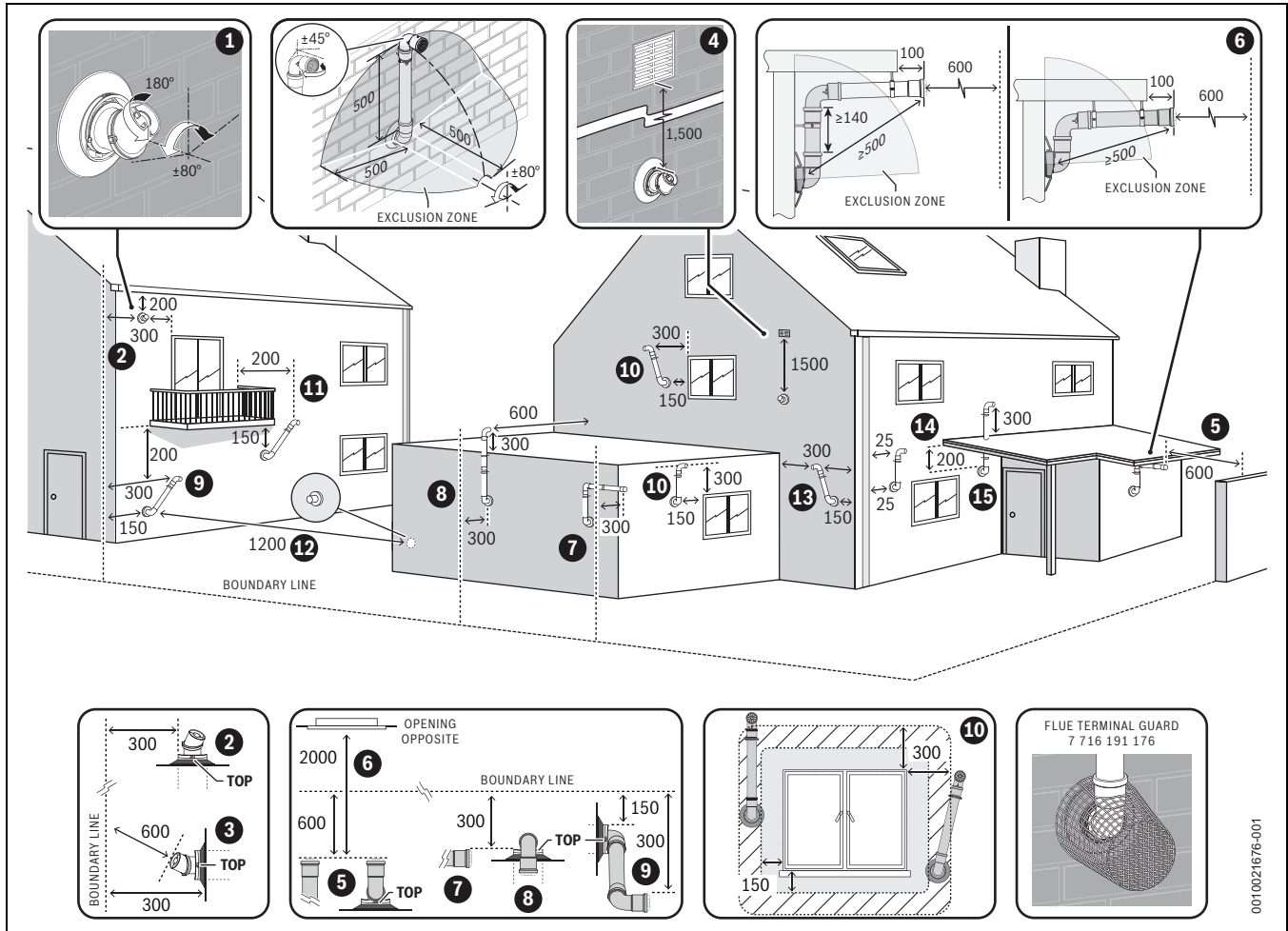

Fig. 30 Plume re-direct and plume management terminal positions

001 0021676-001

Key to figure 30 - Plume re-direct terminal positions:

- [1] This feature allows some basic plume re-direction options on a standard telescopic horizontal flue terminal.
300mm minimum clearances to an opening e.g. window.
However the minimum clearances to an opening in the direction that the plume management is facing, must be increased to 1,500mm.
Where the flue is less than 150mm to a drainpipe and plume redirection is used the deflector should not be directed towards the drainpipe.
- [2] 300mm adjacent to a boundary line, unless it will cause a nuisance. BS 5440: Part 1 recommends that care is taken when siting terminal in relation to surfaces or boundary lines.
- [3] Where the flow of products of combustion is not at right angles to the boundary, the 600mm dimension may be measured in the direction of flow as long as the terminal is not less than 300mm from the boundary.
- [4] When redirecting the flue discharge the terminal end must be at least 1,500mm from any opening in the direction of the discharge to prevent combustion products from entering the building.

Key to figure 30 - Plume management terminal positions:

- [5] 600mm distance facing a surface or a boundary line, unless it will cause a nuisance. BS 5440: Part 1 recommends that care is taken when siting a terminal in relation to surfaces or boundary lines.
- [6] Proximity of flue duct outlet to boundaries, 2,000mm distance to an opening in adjacent building facing a terminal. BS 5440: Part 1 recommends that care is taken when siting terminal in relation to boundary lines.
- [7] 300mm adjacent to a boundary line, unless it will cause a nuisance. BS 5440: Part 1 recommends that care is taken when siting terminal in relation to surfaces or boundary lines.
- [8] 300mm distance from a boundary line to the air intake as long as the exhaust terminal faces away from the boundary line. The exhaust terminal must have a minimum 300mm clearance to a surface below and there must be at least 600mm clearance when measured horizontally in a straight line from the exhaust terminal to any other surface.
- [9] Plume Management kit air intake can be reduced to 150mm providing the flue exhaust outlet is no less than 300mm adjacent to a boundary line.
- [10] Above, below and either side of an opening door, air vent or opening window.
Using a Plume Management kit the air intake measurement can be reduced to 150mm providing the flue exhaust outlet has a 300mm clearance.
- [11] Below balcony or overhang. The air intake clearance can be reduced to 150mm providing the flue exhaust outlet has a 200mm clearance.
- [12] 1,200mm between terminals facing each other¹⁾.
- [13] Internal/external corners. The air intake clearance can be reduced to 150mm providing the flue exhaust outlet has a 300mm clearance.
- [14] Clearances no less than 200mm from the lowest point of the balcony or overhang.
- [15] If a plume management kit is installed within the confines of a carport or other covered, partially enclosed extension, then the exhaust terminal must be positioned at least 1,200mm away from any opening into the building which is sited within the footprint of the carport.
If the exhaust terminal is extended at least 300mm beyond the footprint of the carport then the distance from the terminal to an opening within the carport can be reduced to 600mm.

1) 600mm in case two plume management kits are used on opposing terminals. Each terminal should use a minimum length of 500mm plume management.

The exhaust terminal can also be routed though the roof of the carport providing 25mm clearance is provided around the flue pipe to any flammable material and that it extends at least 300mm above the roof.

The air intake must have a minimum 150mm clearance to any opening in the building in order to ensure the integrity of the structure is maintained. If the exhaust terminates within the footprint of the carport then the carport must have at least 2 sides completely open. If the exhaust terminates at least 300mm beyond the footprint of the carport then the carport must have at least one completely open side. The exhaust terminal must be positioned to ensure that plume will not cause nuisance or damage to vehicles and that minimum clear distances in front of the terminal will not be impeded by vehicles.



Note:

- ▶ Installations in car ports are not recommended.
- ▶ The flue cannot be lower than 1,000mm from the top of a light well due to the build up of combustion products.
- ▶ Dimensions from a flue terminal to a fanned air inlet to be determined by the ventilation equipment manufacturer.
- ▶ Plume kits running horizontally must have at least a 3° fall back to the appliance for proper disposal of condensate, except or the initial horizontal run from the terminal.
The initial plume kit horizontal run will have at least a 10° fall back to the appliance, due to the terminal elbow design, for proper disposal of the condensate.

4.5 Condensate discharge



Full details on condensate discharge.

- ▶ Follow the latest version of **BS6798** and HHIC guidance.

For correct installation and trouble free operation of the appliance the following advice should be followed:

1. **To minimise the risk of freezing, wherever possible: the condensate drain should be installed internally.**
2. All condensate pipework must 'fall' from the appliance by a minimum of 3° (52mm per metre) to ensure adequate condensate flow.
3. The pipework route must allow air to be supplied back to the appliance for correct operation.
4. Connection to a rainwater down pipe must include an air break.

Also:

- Assessment of the risk of the condensate pipe freezing must be carried out and appropriate precautions taken where necessary. This must take into account the specific site conditions.
- The condensate pipework connected to the condensate drain outlet on the appliance should have a minimum internal diameter (ID) of 19mm.
- Keep external pipework as short as possible.
Further precautions against freezing must be taken if external pipe runs exceed 3m.
- External pipework should have a minimum internal diameter (ID) of 30mm.
- Minimise the number of bends and connectors.
- Remove burrs and debris after cutting the pipe.
- Remove surplus solvent from the interior of the pipe.
- The condensate pipework shall be run in standard drainpipe material, e.g. polyvinyl chloride (PVC), unplasticised poly vinyl chloride (PVC-U), acrylonitrilebutadiene styrene (ABS), polypropylene (PP) or chlorinated poly vinyl chloride (PVC-C).

4.5.1 Appliance siphonic condensate trap

The appliance has a large capacity condensate trap reducing the risk of condensate discharge pipework freezing up in prolonged cold temperatures.

The expanded siphonic operation discharges every 10 to 15 minutes. Resulting in:

- Increased velocity and flow rate.
- With less frequent siphonic actions per hour, the condensate pipework is empty for longer.
- Significantly reducing freezing potential for a 48 hour period at -15 °C, provided the installation parameters listed below are followed.

4.5.2 Condensate pipework

NOTICE

General consideration

- ▶ Where a new or replacement appliance is being installed, access to an internal “gravity discharge” point should be one of the factors considered in determining appliance location.
- ▶ Condensate pipe connection at the appliance:
The condensate pipe must have a nominally outside diameter of 22mm plastic pipe.
- ▶ Ensure there are no blockages in the pipe run.
- ▶ Ensure that the discharge method for the installation can effectively handle the condensate waste from the appliance.

Condensate pipework - Unheated internal areas

NOTICE

Unheated internal areas.

Although the large volume siphon will reduce the risk of freezing, condensate discharge may freeze in exposed areas during prolonged cold temperatures.

- ▶ Internal pipe runs in unheated areas such as lofts, basements and garages should be treated as external runs.
For additional information refer to “External Connections” section 4.5.4.

4.5.3 Internal connections



Good Practice

- ▶ The following guidance indicates the good practices that must be maintained for the Installation and Maintenance of a product.

Soil stack connection

→ Figure 31

In order to minimise risk of freezing during prolonged cold spells, the following methods of installing condensate drainage pipe should be adopted.

Wherever possible, the condensate drainage pipe should be routed and terminated so that the condensate drains away from the appliance under gravity to a suitable internal foul water discharge point such as an internal soil and vent stack. A suitable permanent connection to the foul waste pipe should be used.

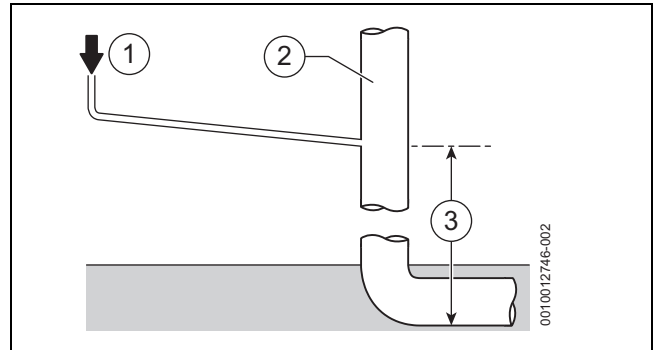

Fig. 31 Disposal to soil vent stack

- [1] Condensate discharge from appliance
- [2] Soil and vent stack
- [3] Minimum 450mm and up to 3 storeys

Waste pipe connection

→ Figure 32

Alternatively if the first option is not possible an internal kitchen, bathroom or washing machine waste pipe etc. can be used.

Ensure that the condensate drain pipe is connected “down stream” of the waste trap and that the condensate drain enters into the top of the pipe using a swept tee.

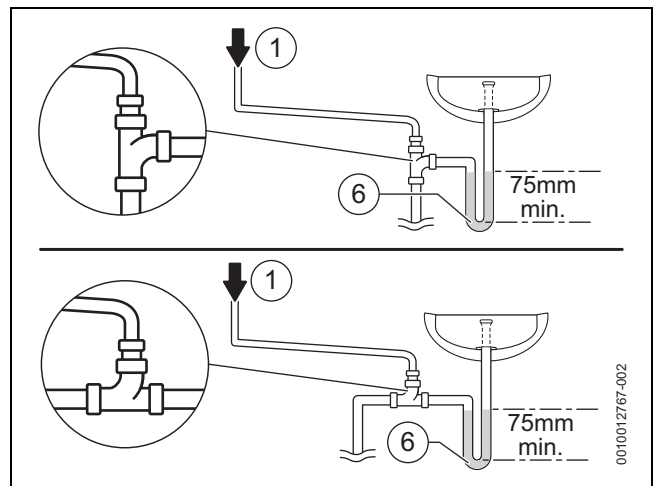

Fig. 32 Waste pipe disposal

- [1] Condensate discharge from appliance
- [6] 75mm sink waste trap

Condensate pump

→ Figure 33

Where direct connection to “gravity discharge” pipework is not physically possible, or where very long internal runs would be required to reach a suitable discharge point, condensate should be removed using a proprietary condensate pump, of a specification recommended by the condensate pump manufacturer.

- The pump outlet should discharge to a suitable “gravity discharge” outlet.
 - The condensate then flows, by gravity, through the 22mm plastic pipe to the condensate discharge point.

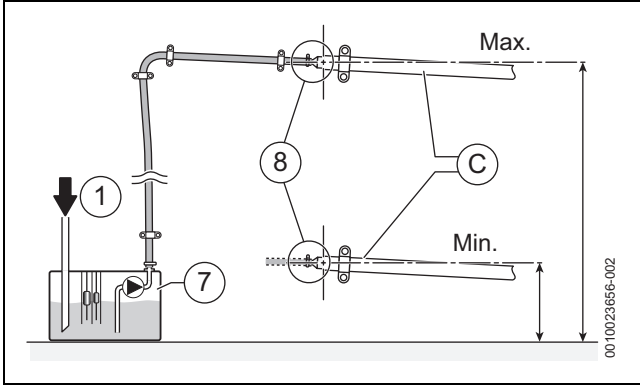

Fig. 33 Condensate pump example

- [1] Condensate discharge from appliance
- [7] Condensate pump
- [8] Pipework transition
- [C] Gravity discharge pipework



Proprietary condensate pump

- ▶ Ensure minimum and maximum pump lifting heights are followed as per condensate pump manufacturers instructions.

4.5.4 External connections

NOTICE

Septic tanks

Untreated condensate must not be allowed into septic tanks.

- ▶ Connection to systems which drain into a septic tank should be avoided due to the risk of affecting anaerobic bacteria.

NOTICE

Rainwater down pipe or external drain disposal

Untreated condensate must not be allowed to flow into streams or rivers.

- ▶ A rainwater down pipe or an external drain shall only be used for condensate disposal if the down pipe or external drain is connected to a combined foul and rainwater drainage system.
- ▶ Refer to BS 6798 for more information on condensate disposal.

NOTICE

Grey water recovery system

Contamination of recovered water

- ▶ Condensate disposal shall not be allowed into a grey water recovery system that is intended for re-use.

External disposal considerations

NOTICE

Freezing conditions

Frozen condensate will block the condensate drain pipe and stop the appliance from running.

- ▶ Pipe lengths should be kept to a minimum and routed as vertically as possible.

NOTICE

Condensate waste disposal

- ▶ Care should be taken when siting a soak-away to avoid causing damage to existing services and building footings.

If no other discharge method is possible then the use of an externally run condensate drainage pipe terminating at a suitable foul water discharge point, or purpose-designed soak away, may be considered. If this method is chosen then the following measures should be adopted:

- ▶ The external run be kept as short as possible and ideally should not exceed three metres. Additional precaution against freezing must be taken if the external pipe run does exceed three metres.
- ▶ The pipe should be run internally as far as possible before going externally and the pipe diameter should be increased to a minimum internal diameter (ID) of 30mm before it passes through the wall to the exterior.
- ▶ The hole through the wall for the condensate pipe should be sleeved and be sealed to the building fabric on the internal and external face using a suitable building material.
- ▶ The external pipe should take the shortest and least exposed route to the discharge point, and should “fall” as steeply as possible away from the appliance, with no horizontal runs in which condensate might stand.
- ▶ The use of fittings, elbows etc. should be kept to a minimum and any internal burrs on cut pipework should be removed so that the internal pipe section is as smooth as possible.
- ▶ All external pipe drainage will be improved if the end is cut at 45° as opposed to a straight cut.
- ▶ In situations where there are likely to be extremes of temperature or exposure, the use of a proprietary trace-heating system for external pipework, incorporating an external frost thermostat, should be considered. All other guidance above and the instructions for the trace heating system, should be closely followed.
- ▶ As well as trace heating, other methods for protecting pipework that are run externally should be considered to prevent freezing during prolonged cold periods.
 - Insulation materials can be used, these should be of class “O” grade with an outer coating that is weather proof and have a UV resistant finish. A minimum of 19mm thick insulation is recommended for 32mm external pipes.
 - The use of a drain cover (such as those to prevent leaf blockage) may offer further protection from wind chill.

Additional protection for transition through a wall.

The external pipework can be insulated to help prevent freezing during prolonged cold periods.

- Where insulation is required, the entire run of external pipework [5] should be insulated with a recess in the external face allowing better insulation protection coverage [4] as it transitions to the outside of the building.
- The hole through the wall must be sealed to the building fabric on the internal [1] and external [3] face using a suitable building material, (use a 40mm sleeve [2] to pass the condensate pipework through and then seal the internal and external faces).

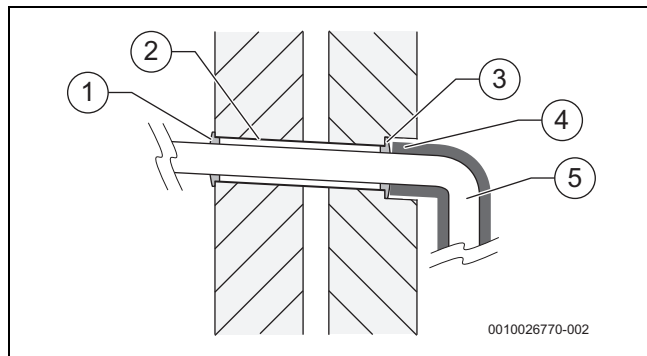

Fig. 34 Additional protection for transition through a wall

- [1] Internal face sealed (32mm pipe sealed to sleeve)
- [2] 40mm sleeve
- [3] External face sealed (32mm pipe sealed to sleeve)
- [4] Insulation recessed into the wall
- [5] Condensate discharge pipe



Good Practice

- ▶ The following guidance indicates the good practices that must be maintained for the Installation and Maintenance of a product.

Rain water down pipe with external air break

→ Figure 35

- Refer to following example to dispose of condensate to a rain water down pipe.
- An air break or rain water hopper must be utilised, between the appliance condensate outlet and the drainpipe, outside the property, to avoid flooding of the appliance should the downpipe become obstructed.

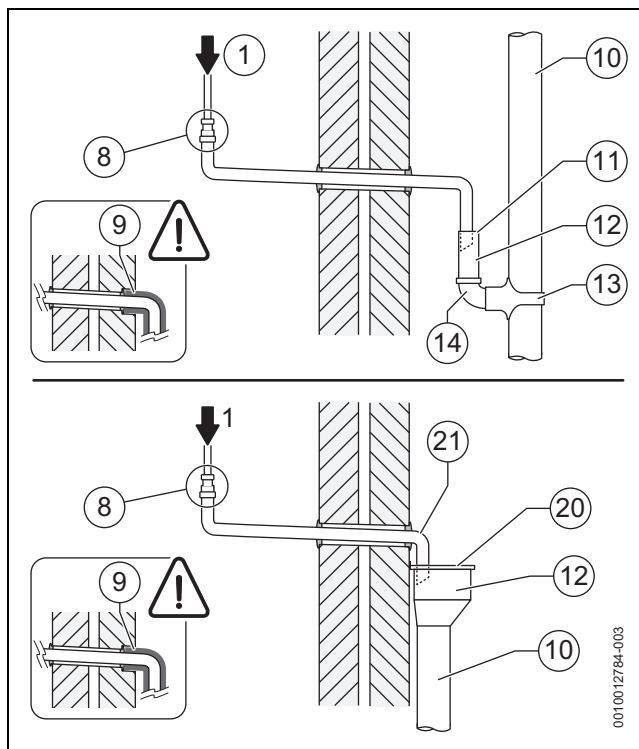

Fig. 35 Disposal into rain water down pipe

- [1] Condensate discharge from appliance
- [8] Pipework transition
- [9] Additional protection for transition through a wall. (→ page 30)
- [10] External rain water pipe to foul water
- [11] External air break
- [12] Air gap
- [13] Strap-on fitting
- [14] 43mm 90° male/female bend
- [20] Rain water hopper
- [21] Increase pipe size

Open drain or gully with external air break

→ Figure 36

Where the pipe terminates over an open drain or gully and there is a risk of ground flooding, then the additional requirement below is recommended:

- An air break should be installed in the external pipework as shown to avoid an airlock during ground flooding/adverse weather conditions which could prevent the condensate from discharging.

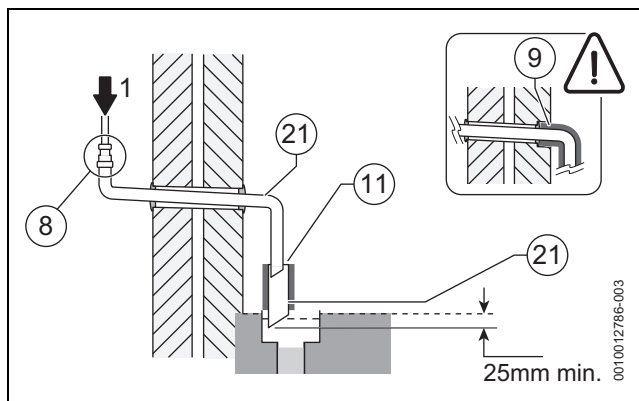

Fig. 36 Disposal to open drain or gully with air break

- [1] Condensate discharge from appliance
- [8] Pipework transition
- [9] Additional protection for transition through a wall. (→ page 30)
- [11] External air break
- [21] Increase pipe size

Condensate soak away considerations

Before deciding to use a purpose-made soak away the history of the locality and the ability of the surrounding area to disperse the condensate should be taken into account, e.g. areas prone to flooding and ground with a high clay content can result in poor drainage with an increased risk of water logging or freezing causing the condensate pipe to become obstructed by water or ice and the boiler to shut down,

Although it is possible to increase the size of the soak away and the area with limestone chippings in clay soil areas, if the clay content is high and prevents effective dispersal of the condensate then a soak away may not be a suitable means of condensate disposal and an alternative method should be used.

Condensate soak away with external air break

→ Figure 37

- Refer to following example to dispose of condensate to a soak away.
- The condensate soak away must be sited at least 500mm away from building footings.
- The condensate drainage pipe may be run above or below the ground to the soak away. The following example shows drainage pipe run above ground.
- The soak away must use a minimum of a 100mm Ø plastic tube with two rows of three 12mm holes on 25mm centres and 50mm from the bottom of the tube. The holes must face away from the house.
- The tube must be surrounded by at least 100mm of limestone chippings to a depth of 400mm.
- An air break must be installed in the external pipework as shown to avoid an airlock during ground flooding/adverse weather conditions which could prevent the condensate from discharging.



Minimum hole size for the condensate soak away must be 400mm deep by Ø 300mm.

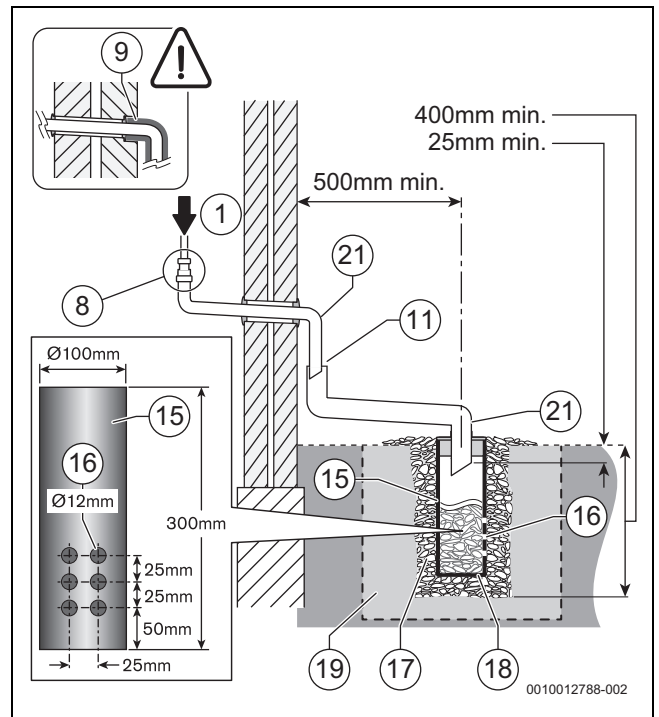

Fig. 37 Disposal to soak-away

- [1] Condensate discharge from appliance
- [8] Pipework transition
- [9] Additional protection for transition through a wall. (→ page 30)
- [11] External air break
- [15] 100mm minimum Ø plastic pipe
- [16] Drainage holes
- [17] Limestone chippings
- [18] Bottom of sealed tube
- [19] Increase size of soak away size and the area with limestone chippings if in clay soil area.
Not recommended for high clay soil areas.
- [21] Increase pipe size



Minimum Standard

- The following guidance indicates the minimum standards that must be maintained for the Installation and Maintenance of a product.

Appliances with large capacity condensate trap or CondenseSure accessory or have trace heating fitted.

The need to insulate the pipework through the wall is not normally required for appliances with a large capacity condensate trap or CondenseSure/trace heating fitted for external runs under three metres. These pipes should be sleeved though the wall and the insulation recessed when used.

Cavity wall considerations:

- Whilst insulating the pipe through a typical external wall is unlikely to be required for added protection against freezing in most circumstances, it might be a consideration where the property is located in particularly cold, exposed areas, has an uninsulated cavity or perhaps an unusual construction where there is a larger than normal cavity between the inner and outer wall.

Trace heating fitted:

- Check with trace heating manufactures instructions for additional requirements.

Large capacity condensate trap or CondenseSure fitted to the appliance:

- External pipework exceeding three metres in length or an installation with increased risk of freezing due to environmental factors:
 - Additional protection of insulating the entire run of the condensate pipework [2] should be carried out. The pipe should be insulated externally using suitable waterproof and weather resistant insulation.
 - The hole through the wall must be sealed to the building fabric on the internal [1] and external [3] face using a suitable building material.

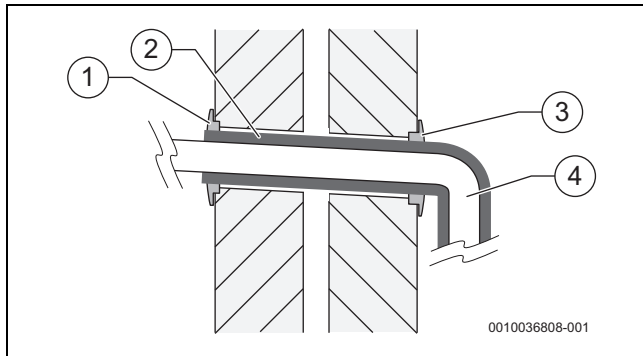

Fig. 38 Through the wall lagging example

- [1] Internal face sealed
- [2] Insulation
- [3] External face sealed
- [4] Condensate discharge pipe

4.6 Pressure relief discharge

4.6.1 Pressure relief pipework



CAUTION

Scalding risk from hot water or steam!

- The pressure relief valve (PRV) is an appliance safety device and may discharge hot water or steam when activated.
- The outlet pipe should be sited in such a way that it does not cause a hazard or an obstruction when discharging, for example above a window, entrance door or other public access way.
- The point of termination should provide a visual indicator in case the PRV discharges.

- The pressure relief discharge pipe [1 or 3] should be run in pipe which has a diameter of at least 15mm, that is made of copper or a material that will withstand PRV discharge temperatures and pressures, and which complies with BS 5254 or BS EN 1451.
- Plastic pipework must be properly supported with a maximum of 300mm between supports to prevent sagging.
- The PRV discharge pipe must run continuously downwards away from the appliance to a safe point of discharge.
- The pressure relief should discharge away from any electrical or other hazard, preferably to an external drain or soak-away.
- The pipe [1 or 3] should be finished with a partial bend, to face the external wall (as shown) to ensure safe discharge of hot water.
- In all normal circumstances a PRV discharge pipe installation as described above sufficiently meets all but the most exceptional circumstances.
 - Where the PRV discharge pipe could be susceptible to damage, vandalism, freezing etc that could cause either a blockage or restriction in the ability to discharge safely then a tundish should be considered. The tundish should be sited in a position where damage to the property or injury to occupants cannot occur from any spillage or discharge.

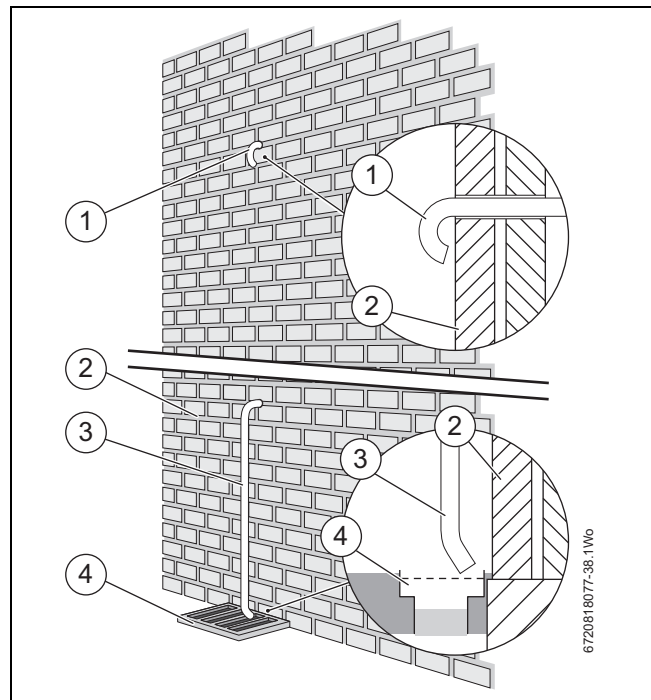

Fig. 39 Pressure relief pipework

- [1] Discharge pipe (turned back onto external wall example)
- [2] Outside wall
- [3] Discharge pipe (into drain or gully example)
- [4] External drain

4.6.2 Alternative PRV connections - Combined PRV/condensate

The PRV or a combined PRV/condensate discharge can be connected into a suitable internal waste system, the installer must ensure that all the pipework, including the waste pipe, is capable of withstanding PRV temperatures and pressures.

Connection to a waste water pipe is possible by using either:

- A shielded tundish with non-return valve used to discharge upstream of a trap (there must not be a trap directly in the PRV discharge pipe without a tundish).
- A PRV can discharge directly into a suitable waste pipe downstream of a trap. Connections must be on top of the pipe to ensure they do not block. A Hotun (or similar) can be fitted for visual indication if desired but is not necessary.

The guidance of BS 6798 sections 6.3.5 and 6.4.3.2a must be followed.



For installations where it is not possible to run the PRV discharge pipe continuously downwards away from the appliance, the remote PRV kit can be used to remove the PRV from the appliance and relocate it to a higher position.

4.7 Cleaning primary systems

NOTICE

Risk of damage to system or appliance!

Debris from the system can damage the appliance and reduce efficiency. Failure to comply with the guidelines for the use of water treatment with the appliance will invalidate the appliance guarantee and contravene the Building Regulations.

- ▶ It is a requirement of the Building Services Compliance Guide which is a second tier document to the Building Regulations to flush and inhibit the primary water system in accordance with BS 7593.
- ▶ The Building Services Compliance Guide recommends that a primary water cleanser is fitted to the system.
- ▶ Worcester Bosch recommend fitting a filter that will help remove both magnetite and non-magnetic debris. Worcester offers three filters that help remove both magnetite and non-magnetic debris; 22mm mini 7 733 600 266, 22mm version, part number 7 733 600 236 and a 28mm version, part number 7 733 600 237.

NOTICE

Risk of damage to system or appliance!

- ▶ Salt based, artificially softened water that adjusts the pH value MUST NOT be used to fill the system.
- ▶ Alternatively there are water softening/treatment products that do not adjust or alter the pH levels of the water. With these products it may not be necessary to provide an untreated water by-pass to the primary water filling point of the heat system

NOTICE

Sealing agents

Normally the addition of sealing agents to the system water is not permitted as this can cause problems with deposits left in the heat exchanger.

- ▶ Heating systems may lose small amounts of water over time. In cases where all attempts to find a system micro leak have failed, Worcester, Bosch Group supports the use of Fernox F4 leak sealer.

Before cleaning the system:

- ▶ Ensure that the system and pipework is in good working order.
- ▶ **Where possible keep the existing appliance/circulating pump in place when flushing the system before installing the new appliance. Alternatively use an after market power flushing system or similar to remove magnetite and other debris from the central heating system.**
 - Even new central heating systems contain contaminants that need to be removed before treating the system with inhibitor/anti-freeze.
 - When an appliance is installed onto a new system then it is possible to use the appliance whilst cleaning the system. A system filter must be fitted to the return to reduce the risk of contaminants entering the appliance.
- ▶ **Follow the guidance of BS7593.**

Inhibitor

Add a suitable inhibitor or combined inhibitor/anti-freeze, if the system is exposed to freezing conditions, to the heating system in accordance with the DWTA code of practice and manufacturer's guidelines.

Products approved to the BuildCert standard are deemed as compatible with the components and equipment within the appliance and system.

Water treatment products

Suitable water treatment products can be obtained from the following manufacturers:

ADEY	01242 546700 www.adey.com
FERNOX	0330 100 7750 www.fernox.com
SENTINEL	01928 704330 www.sentinelprotects.com/uk

Table 12

4.7.1 Flushing the system

Flushing the system using existing appliance/circulating pump or new appliance.



Existing appliances/circulation pumps

- ▶ An existing appliance/circulating pump should be used to flush the system before the new appliance is installed.



New appliances

- ▶ A new appliance must only be used to assist the cleaning of a **newly installed** system.

- ▶ Fill the system with cold water and check for leaks.
- ▶ Open all drain cocks and drain the system.
- ▶ Close drain cocks and add a suitable flushing agent **compatible with aluminium** at the correct strength for the system conditions in accordance with the manufacturer's instructions.
- ▶ Mark the position of the lockshield valves and open them fully.
- ▶ Fully open all TRVs.
- ▶ Circulate the flushing agent before the appliance is fired up.
- ▶ Run the appliance/system at normal operating temperature as directed by the manufacturer of the flushing agent.
- ▶ Drain and thoroughly flush the system to remove the flushing agent and debris. Do not drain the system through the PRV of new appliances.
- ▶ It may be necessary to use a power flushing machine to aid the cleansing procedure in some circumstances.
- ▶ Close the drain cocks and manual air vents.

For existing appliance/circulating pump actions.

- ▶ Add a suitable inhibitor to the system in accordance with the manufacturers instructions.
- ▶ Fill the system to between 0.8 and 1.7 bar via a WRAS approved filling loop.
- ▶ Vent any air from the appliance and system.

For new appliance.

- ▶ Once the new appliance has been installed follow the guidance in Filling the appliance and adding inhibitor section.

5 Installation

NOTICE

Risk of damage to appliance or accessories.

- ▶ All the previous pre-installation sections must be read and requirements met before starting the appliance or flue installations.



CAUTION

Risk of injury through incorrect lifting and carrying!

- ▶ Only lift a manageable weight, or ask for help.
- ▶ Bend the knees and keep the back straight with feet apart, when lifting or putting down heavy objects.
- ▶ DO NOT lift and twist at the same time.
- ▶ Lift and carry object close to the body.



Appliance on site

- ▶ Check contents of delivery are undamaged.
- ▶ Remove the appliance from its packaging check the contents against the scope of delivery.
- ▶ Once the appliance is unpacked the installation can commence.

Important handling instructions

- It is advised that two people are used to carry the carton from the vehicle to the point of delivery.
- Once the carton is in the property, the outer carton is removed first. Care should be taken when releasing the straps. If a sharp implement is used make sure the outer carton is not pierced and that the implement is used in such a way so that it may not cause personal injury.
- All sharp objects must be covered or the blade retracted after use and put away in a safe place. Care should be taken when lifting the appliance from the base and the proper technique for safe lifting of any heavy object should be strictly observed.

Unpacking

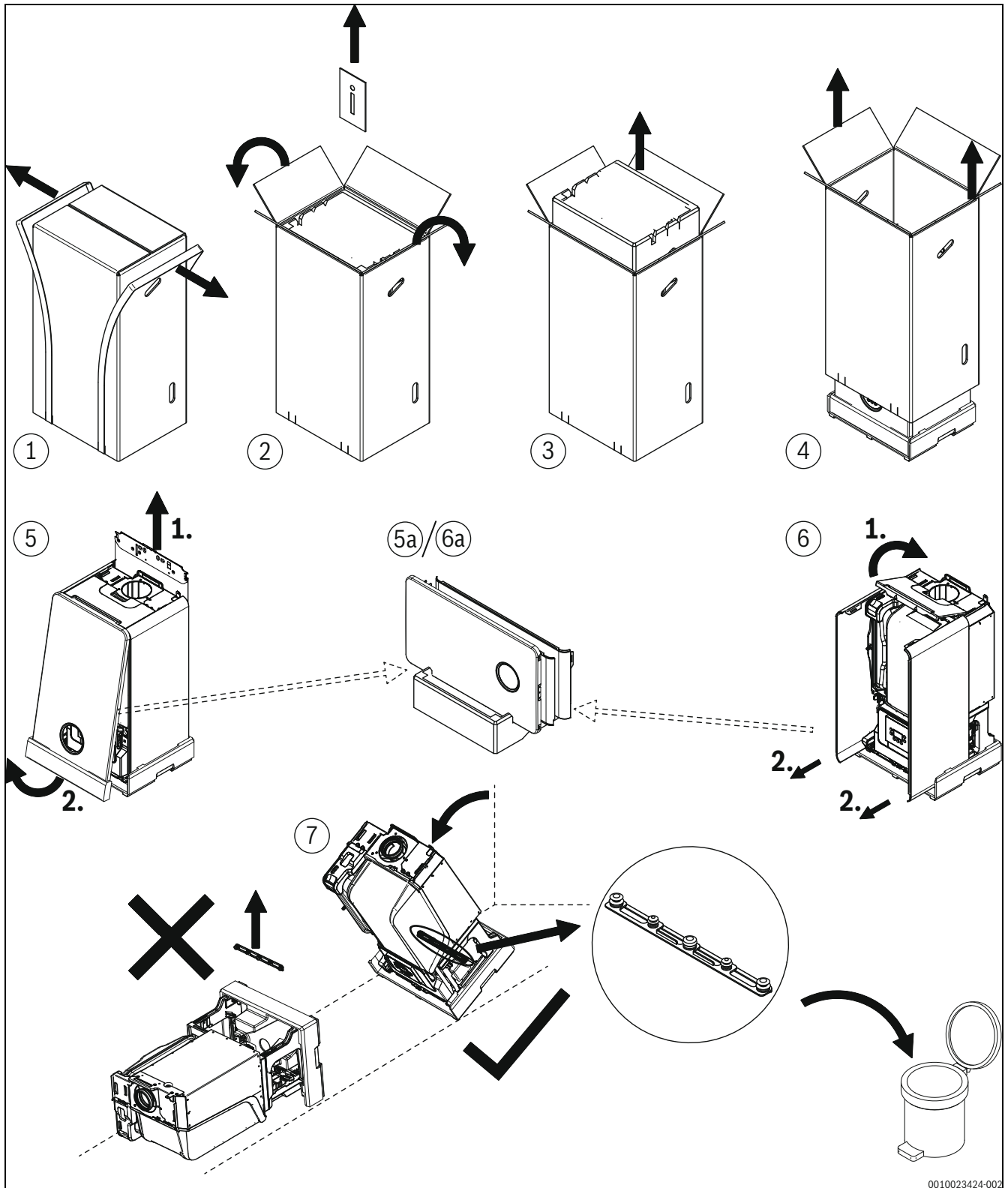

0010023424-002

Fig. 40 Unpacking

Additional requirements for roof space installations

- The unpacked appliance can now be moved into the loft space
- Two sets of steps should be used.
- Two people should share the lifting of the appliance up to the loft hatch, tilt and slid on its back into the loft space.
- Ensure that the roof space has permanent fixed lighting, a permanent fixed retractable ladder and a fixed floor area, from the hatch to the appliance installation point. This will allow access for installation, normal use and servicing.



Before installing the appliance, ensure that the system has been cleaned.

5.1 Position the appliance



WARNING

- ▶ Ensure the mains gas supply is isolated before starting any work and follow all relevant safety precautions.



Appliance positioning

- ▶ Ensure the appliance is mounted onto a flat, fixed rigid surface capable of supporting the appliance weight.
- ▶ Ensure all aspects of the installation are considered when positioning the appliance, flue run and discharge, condensate disposal, PRV discharge etc.



WARNING

Damage to property!

Damage caused by drilling into pipes, electrical cables, damp proof course or other hazards.

- ▶ Before drilling ensure that there are no obstructions or other hazards.

NOTICE

Damage to appliance!

Residue, metal shavings, and contaminants in the system pipework can damage the appliance.

- ▶ Flush the system pipework thoroughly to remove all residue.
- ▶ Follow the instructions with respect to cleaning primary systems.

Running pipes behind the appliance.

- Do not cross pipes over one another.
- Consider the routing of the flue pipe prior to fixing the position of additional pipework.
- Only follow the routing defined on the wall mounting template.

5.1.1 Mounting frame fixing



simple switch Existing wall fixings positions (CDi Classic)

- ▶ The existing wall fixings can be used only if they are still deemed by a competent person able to support the new appliance.



Wall mounting template

- ▶ The wall mounting template has been sized to allow for the minimum clearances around the appliance (→ chapter 4.3.3 "Appliance clearances").

→ Figure 41

The appliance wall mounting template shows the relative positions of the flue and the top and bottom fixings of the wall mounting frame.

- ▶ Fix the wall mounting template [3] to the wall in the desired position.
- ▶ Drill the holes [4] through the template for the primary fixing points as indicated on the template.
 - Additional fixing points for the appliance will be indicated on the wall mounting template.

Flue outlet position.

The appliance wall mounting template has the flue centre lines for the following flue systems:

- 60/100mm
- 80/125mm



Flue turret

- ▶ The flue turret has an in-built 3° angle giving the flue assembly the rise from the appliance to ensure the condensate flows back to the appliance.

Rear flue outlet [2].

- ▶ Mark centre line of flue to be used; the external diameter of the hole can also be marked if required.
- ▶ If extensions are to be added then the complete flue must rise at an angle of 3° from the appliance.

Side flue outlet [1].

- ▶ Mark from the centre line of the wall mounting template to the wall which the flue will pass through.
- ▶ Allow for a rise of 52mm per metre length of flue, to give a 3° angle.

Example hole size.

- If a 60/100mm diameter flue is to be used, a 125mm diameter hole is required.
- If using the weather sealing collar by pushing it through from inside the property, then a 150mm diameter hole is required to accommodate this.

Flue outlet position marked and ready to drill hole.

- ▶ Drill hole using a core drill or similar.
- ▶ Clear any debris from the site.

Appliance fixings and flue outlet drilled and ready.

- ▶ Remove the wall mounting template.

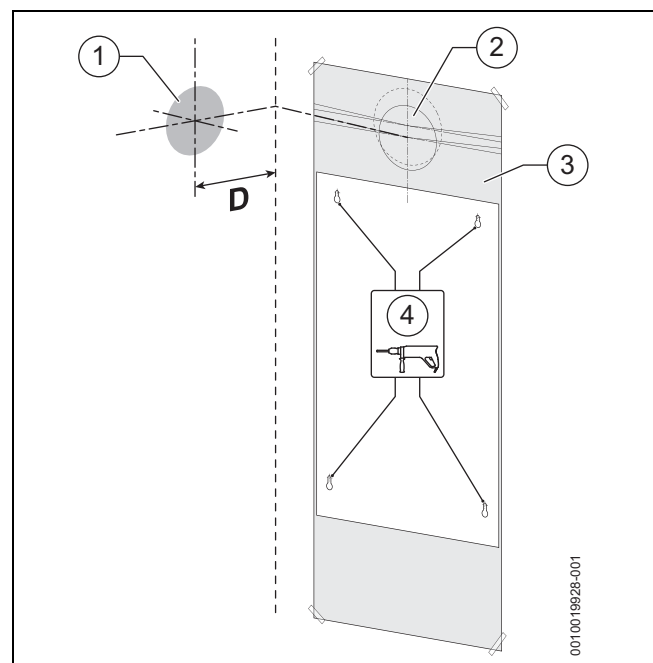

Fig. 41 Wall mounting template

- 1 Side exit flue example
- 2 Rear exit flue example
- 3 Wall mounting template
- 4 Primary fixing points
- D 87mm

Carry handles

For transportation of the appliance always use the carry handles [1] and [2] (with the control unit in the closed position).

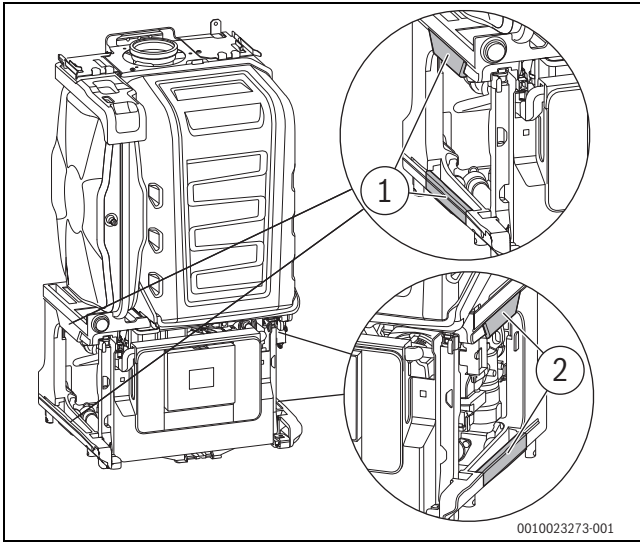

Fig. 42 Transport, lifting and handling

Preparing the appliance installation

NOTICE

Incorrect mounting can cause material damage.

If the appliance is mounted incorrectly, it may fall off the wall.

- ▶ Only install the appliance on a rigid, solid wall. This wall must be able to carry the weight of the appliance and must at least be as large as the bearing surface of the appliance.
 - ▶ Only use screws and wall plugs that are suitable for the wall type and weight of the appliance.
-
- ▶ Remove the packaging, observing all notices in the packaging.
 - ▶ Make sure that the gas type specified on the data plate is the same as the gas type supplied.
 - ▶ Make sure that the installation location is in the country of destination specified on the data plate.
 - ▶ Fasten the wall mounting plate to the wall using 4 screws and wall plugs.
 - ▶ Attach the pre-plumbing manifold to the lower screws and tighten.

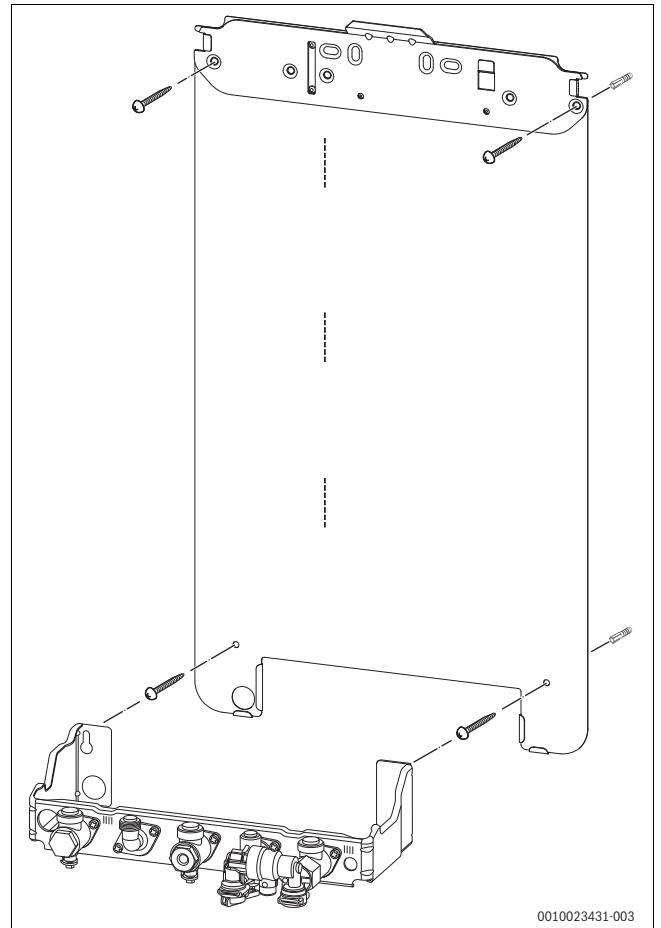

Fig. 43 Fitting the wall mounting plate and pre-plumbing manifold

5.2 Appliance connections

! WARNING

Appliance - gas connection

- ▶ **Ensure the mains gas supply is isolated before starting any work and follow all relevant safety precautions.**

NOTICE

Appliance - hydraulic connections

- ▶ Ensure all water pipework, to be connected, are isolated/drained and follow all relevant safety precautions.
- ▶ Be careful of plastic components when using a naked flame on pipework.

i

Surplus water may be present inside the appliance due to factory testing.

i

External condensate pipework or internal pipe runs in unheated areas such as lofts, basements and garages exposed to prolonged cold temperatures should be protected (→ chapter 4.5).

NOTICE

Commissioning without water damages the appliance!

- ▶ Operate this appliance only when filled with water.

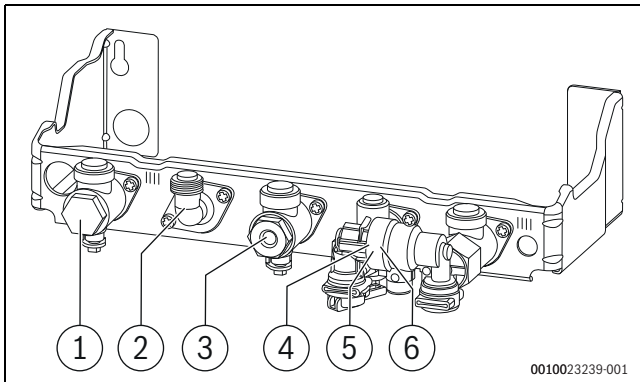

Fig. 44 Connections on the gas and the water side

- [1] Heating flow valve
- [2] Hot water
- [3] Gas isolator
- [4] Cold Water inlet
- [5] Keyless filling link
- [6] Heating return valve

Preparing the pre-plumbing manifold

- ▶ Fit sealing washers to service valves before hanging appliance.

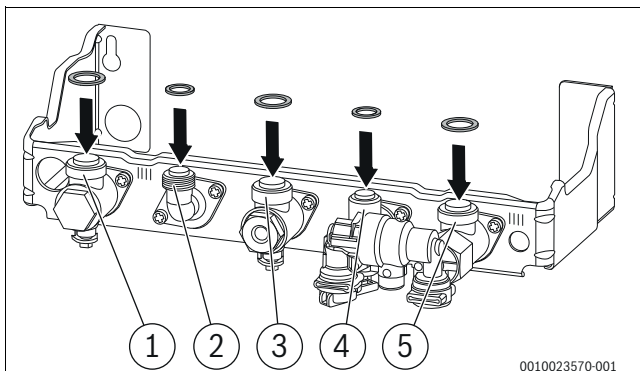

Fig. 45 Fitting the sealing washers

- [1] CH flow
- [2] DHW outlet
- [3] Gas inlet
- [4] Domestic Cold Water inlet
- [5] CH return



Before hanging the appliance onto the wall mounting frame ensure that the pressure relief discharge pipe is connected securely.

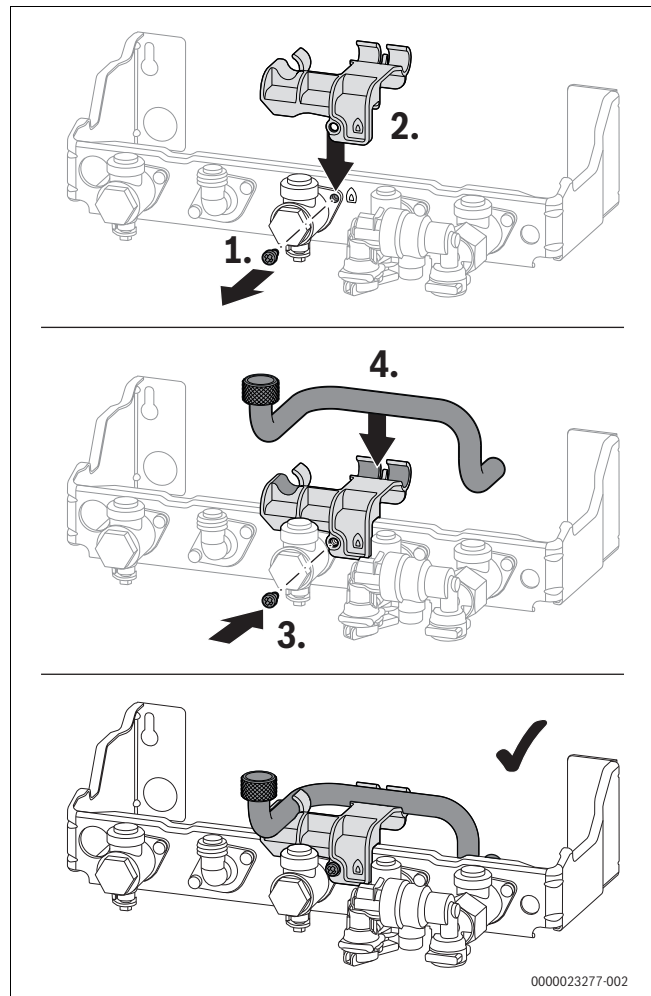

Fig. 46 Connect PRV discharge pipe

5.3 Hanging the appliance

Before hanging the appliance

- ▶ Remove the orange plastic protective cover strip fitted to the appliance internal pipes by tilting the appliance forward, taking care to protect the floor from residual water. It is not necessary to lay the appliance on its back.
- ▶ The appliance is a 2 person lift. Ensure that the control panel is in its closed position and the top and side panels are removed before lifting the appliance.

Hanging the appliance

- ▶ Ensure that top and side panels are removed.
- ▶ Fit the sealing washers to service valves.
- ▶ Hang the appliance on to the wall mounting frame by the centre hook.
- ▶ Unlock the condensate trap and remove from appliance (→ Fig. 96).
- ▶ Check the positioning of the sealing washers on the pipe connections.
- ▶ Tighten the union nuts on the pipe connections starting with the CH return on the right.



It is recommended th ng operation is carried out by 2 people, observing all precautions for safe lifting of heavy objects.

Do not lift by the top case panel. There are two handling holes incorporated into the inner casing left and right in the lower section of the appliance (→ Fig. 42).

CAUTION

Damage to boiler

Boiler may fall and/or not work properly.

- ▶ Make sure the boiler fits tightly the designated grooves [1] in the manifold.

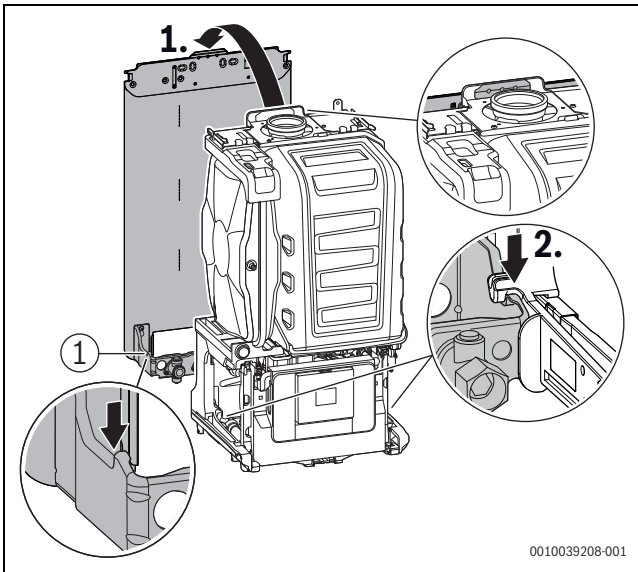

Fig. 47 Hanging the boiler

- ▶ Make connections between the boiler and the pre-plumbing manifold and the pre-plumbing manifold and the system pipes.
- ▶ Connect the CH flow pipes to the boiler's 22mm compression connections.
- ▶ Connect the CH return pipes to the boiler's 22mm compression connections.
- ▶ Connect the gas supply to the boiler gas cock 22mm compression.
- ▶ Connect cold water in and DHW out to the boiler's 15mm compression connectors.
- ▶ Connect the PRV discharge pipe to the heating pressure relief valve, ensuring that it is tightened securely.
- ▶ Connect the condensate discharge pipe work to the boiler's condensate outlet connections.

Fitting the drain pipe on the heating pressure relief valve

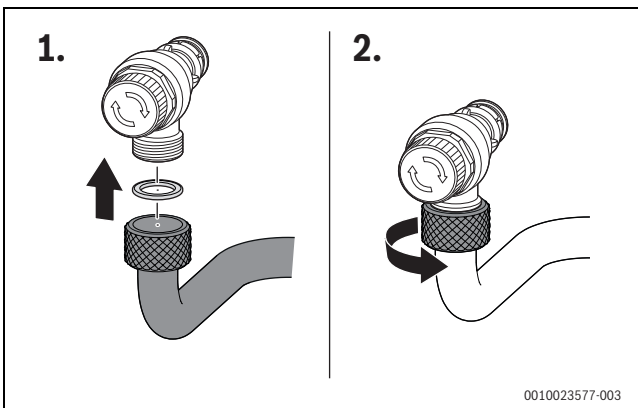

Fig. 48 Fitting the pipe on the (heating) pressure relief valve

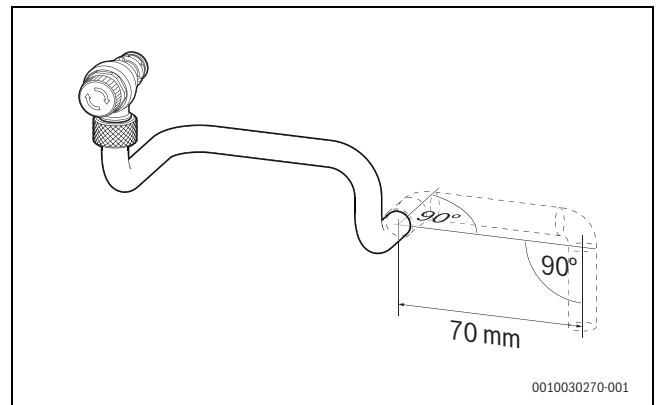

Fig. 49 Discharge pipe to existing CDI classic position (not in the hardware pack)

Fitting the condensate pipework

- ▶ Secure the pipe to the wall at the last joint.
- ▶ Ensure the pipe protrudes through the pre-plumbing manifold by 25mm.
- ▶ If exiting through the wall, to run externally, the pipe must have a 3° fall and be increased to a 32mm insulated pipe.

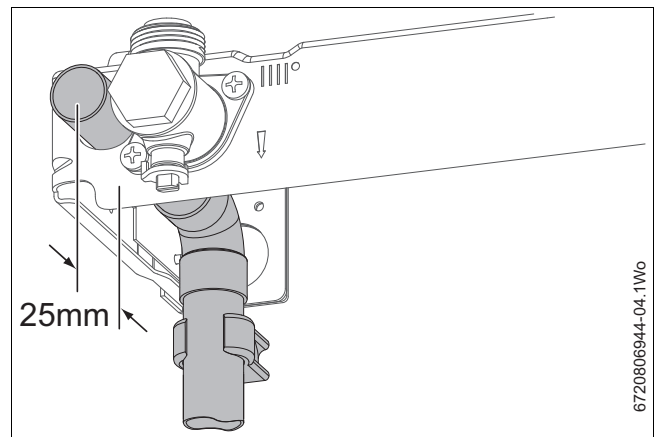

Fig. 50 Fitting the condensate pipes to the mounting plate

Condensate connection

Never terminate or discharge into any open source, including; sink, bath, shower, bidet, toilet etc.

i

Any external condensate pipe work of an excessive run should be protected with weather resistant insulation to help prevent freezing (→ chapter 4.5).

- ▶ Ensure that the condensate drain is 22mm diameter plastic pipe. It must fall at least 52mm per metre towards the outlet.
- Refer to Fig. 51, condensate connection:
- ▶ Align the installation side plastic pipe work through the pre-plumbing manifold.
 - ▶ Connect the installation side plastic pipe work to the end of the condensate hose.
 - ▶ Push the plastic pipe work inside the condensate hose at least 25mm.

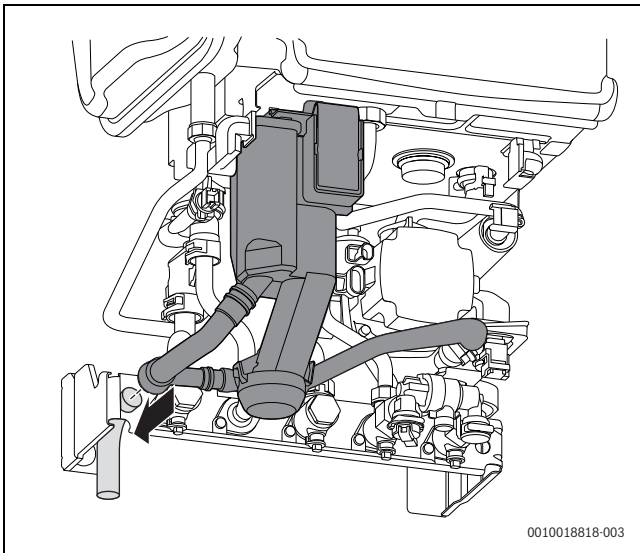

Fig. 51 Condensate connection

Filling the condensate trap

! DANGER

Danger to life from poisoning!

If the condensate trap is not filled, poisonous flue gas can escape.

- ▶ Fill the condensate trap with approx. 250 ml water via the flue pipe.

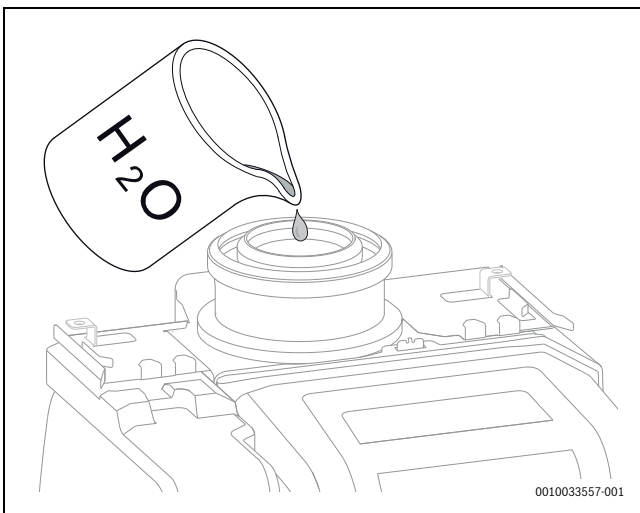

Fig. 52 filling the condensate trap with water

5.4 Flue turret/adaptor installation

NOTICE

Flue installation

- ▶ Refer to the Flue Kit Installation instructions provided with your flue kit to correctly install the flue with this appliance.
- ▶ Do not exceed the maximum straight length for a horizontal or vertical flue or a 60mm plume management system (if used) as stated in chapter 4.4.

i

Telescopic flue

- ▶ Cutting the flue to an exact measurement is not required as the telescopic flue terminal can allow for some adjustment.

i

Apply silicone lubricant to sealing surfaces, to ease assembly of flue components. Refer to the manual supplied with the flue kit for complete installation instructions.

- ▶ For plume management and effective flue lengths (→ chapter 4.4).

Additional notes and reminders:

- Ensure that all cut lengths are square and free from burrs and cutting/filing debris.
- Ensure that the flue and seals are not damaged.
- The flue is sealed when assembled correctly, the components are pushed fully home and secured.
- The flue rises from the appliance at an angle of 3° or 52mm per metre length.
- Support the flue at each flue extension joint and at each change of direction, use suitable brackets and fittings:
 - Support bracket kit (silver), part number 7 738 112 876
 - Flue bracket 100mm, part number: 7 716 191 177.
 - Flue brackets 100mm x 6, part number: 7 716 191 178.
 - Flue bracket 125mm, part number: 7 716 191 179.
- Ensure the external wall seal is fitted and properly located in the groove provided on the terminal. This seal must be installed in the groove unless the flue is extended beyond a gutter or balcony as shown in the installation instructions.

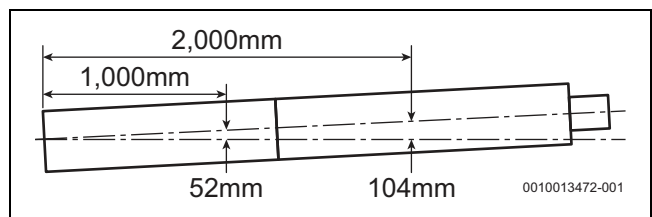

Fig. 53 Slope for condensate disposal

- ▶ Remove the three inner flue tube retaining screws [1].
 - The inner tube will be held in place in the appliance.
- ▶ Check the appliance flue seal [2] is correctly seated and apply silicone grease.

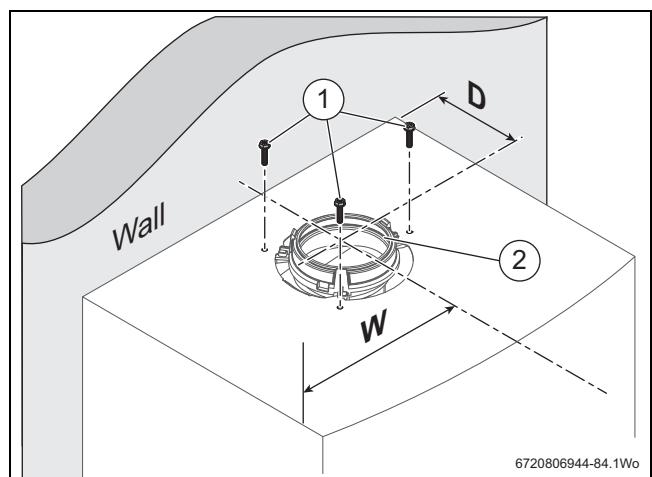

Fig. 54 Flue turret centre

- [D] 87mm
- [W] 220mm

- ▶ Align the flue turret/vertical adaptor to the appliance flue outlet with flat facing [3] to the rear of the appliance. The flue turret/adaptor should be pushed straight down, on to the appliance.

- ▶ The three inner flue tube retaining screws [1] are, re-used for the flue turret and replacement retaining screws [4] supplied with the adaptor kit are used to secure turret/adaptor to the appliance.

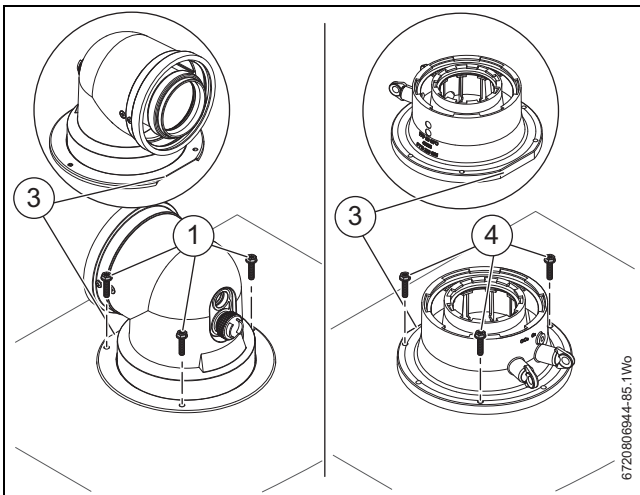

Fig. 55 Flue turret/adaptor connection

5.5 Electrical connection

⚠ DANGER

Risk of electric shock!

- ▶ Isolate electrical components from the power supply (230 V AC) (fuse, circuit breaker) and secure against unintentional re-connection before carrying out any work. Information on safe isolation can be found in the Health and Safety Executive guidance HSG85.
- ▶ Check for zero potential before proceeding with work, using test equipment approved to GS38 to confirm that the electricity supply is disconnected.

i

Electrical considerations:

- ▶ All electrical work must be carried out by a competent and authorised person.
- ▶ All work must comply with the current IET Wiring Regulations.
- ▶ The isolator shall be situated next to the appliance for new systems and, where practicable, replacement appliances.
- ▶ The mains electrical supply to the appliance must be through a fused double pole isolator.
- ▶ The isolator must have contact separation of 3mm minimum between poles. Any system connected to the appliance must not have a separate electrical supply.
- ▶ Any additional components that are connected to the appliance that require 230 Volts must be connected to the same supply as the appliance.
- ▶ The correct type of RCD must be employed where additional protection is required that is suitable for a low energy DC modulating pump according to IET wiring regulations.
- ▶ External fuse 3A Amps.
- ▶ When stripping the wires, ensure copper strands do not fall into the control box.

NOTICE

Risk of damage from hot appliance components.

Hot appliance components can damage electrical cables.

- ▶ Ensure all electrical cables are in the correct cable guides and away from hot appliance components.

i

Cable routing

- ▶ Route cables through support guides and retaining clips.
- ▶ Run power cables separately from signal cables. Interference from power cables can induce spurious faults on signal cables, ensure that there is at least 100mm separation from each other.
- ▶ Ensure the cables are of sufficient length to allow the control box to be moved to the service position.

If the power cable is of insufficient length and is to be replaced, access the connection terminal (→ Fig. 56)

- ▶ Replace with the following cable type:
 - H05V2V2F x 0.75 mm² (heat resistant PVC, for fixed installation appliances, in accordance with the latest edition of national and local wiring regulations)
 - A spare strain relief is supplied in the hardware pack, if required.
- ▶ Connect the cable so that the protective conductor (earth) is longer than the other wires.

5.5.1 Installer connections

Connect external accessories

- ▶ Flip down the control appliance (→ Fig. 56).
- ▶ Open the cover.

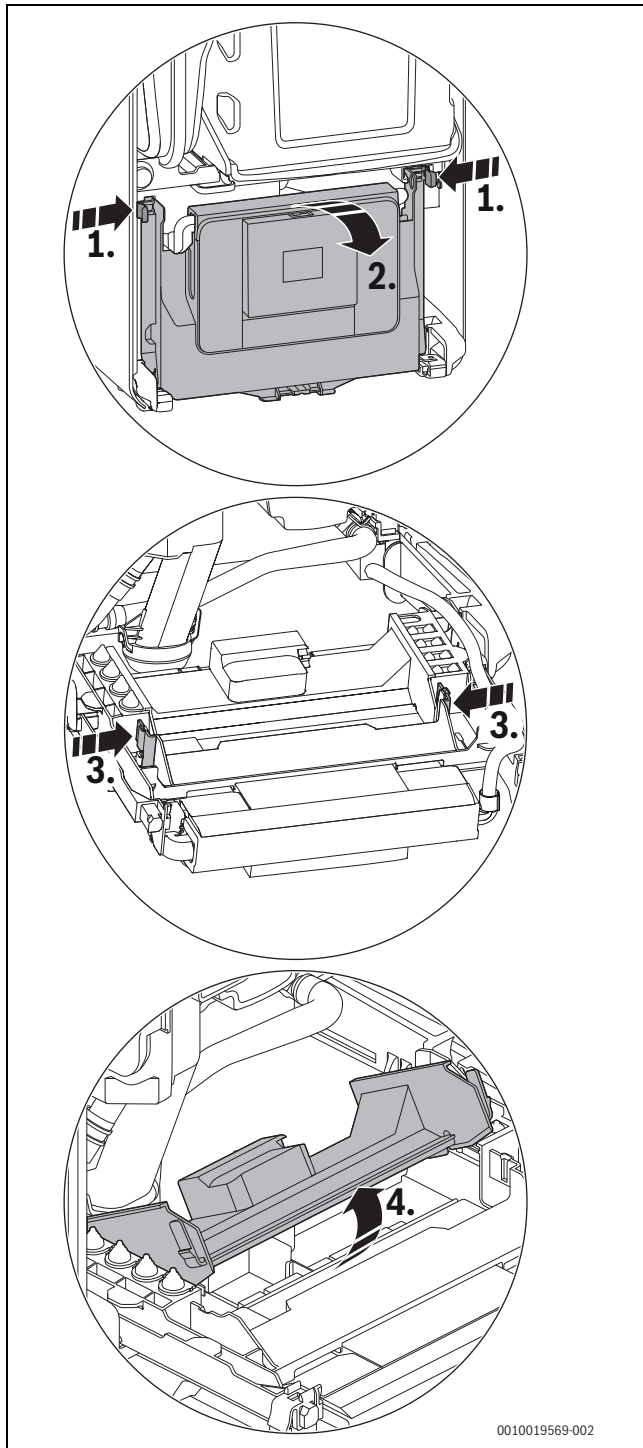

Fig. 56 Opening the cover

Access to the electrical connections once the cover is opened.

- ▶ For splash water protection (IP): cut the strain relief to match the diameter of the cable.

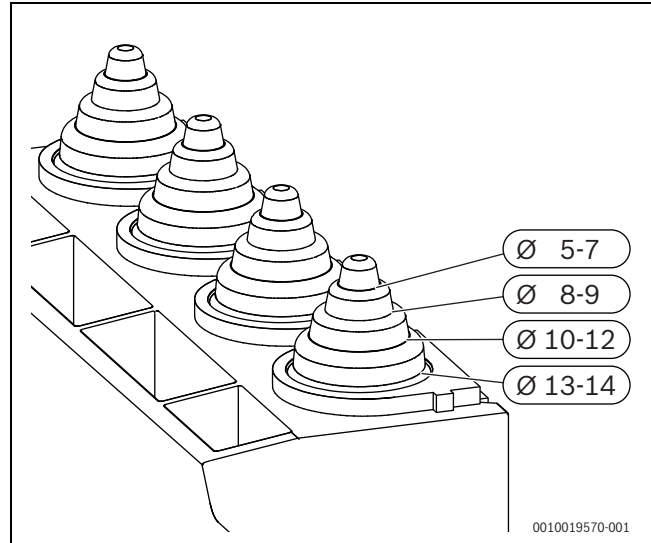

Fig. 57 Adapting the strain relief to the cable diameter

- ▶ Guide the cable through the strain relief.
- ▶ Connect the cable to the terminal strip for external accessories.
- ▶ Secure the cable on the strain relief.

Power supply (power cables) terminal strip

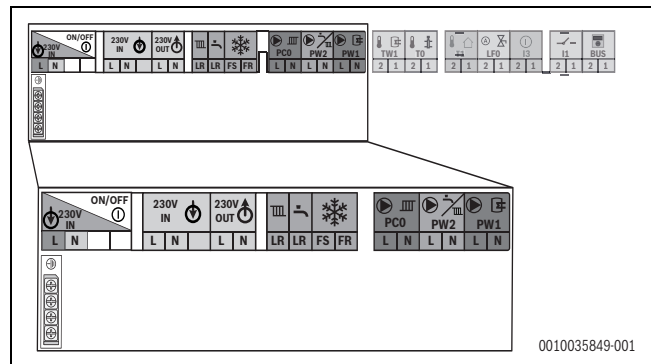

Fig. 58 Power supply (power cables) terminal strip

Power supply (power cables) connections

Symbol	Function
	Protective earth bar ▶ Connect the protective earth for power supply.
	Power supply (power cable) Pre-wired cable (Live and Neutral)
	No functionality; not used
	230V mains output to external controls/wiring centre ▶ If required: connect power supply for external controls.
	Switch live (Live Return) to appliance • CH demand input • DHW demand input (pre-heat time control)
	External frost thermostat • FS output (frost thermostat supply) • FR input (frost thermostat return)

Symbol	Function
	No functionality; not used
	No functionality; not used
	No functionality; not used

Table 13 Power supply (power cables) terminal strip for external accessories

Low voltage (signal cables) terminal strip

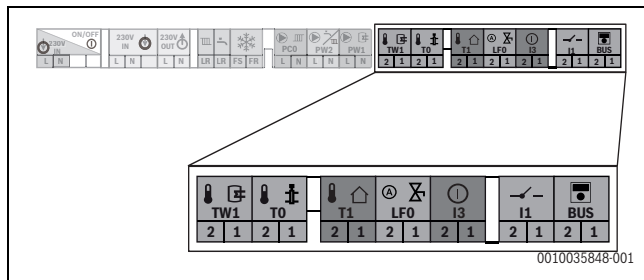

Fig. 59 Low voltage (signal cables) terminal strip

Low voltage (signal cables) connections

Symbol	Function
	Low-loss header temperature sensor
	DHW solar pre-heat accessory
	Outdoor weather compensation sensor (used when accessory outdoor sensor is connected) ▶ Connect the outside temperature sensor.
	Auto filling link contact ▶ Connect the auto filling link cable. ▶ Switch on the automatic filling facility in the service menu under Settings > Special function and program it according to the heating system.
	Without function
	On/Off thermostat input
	External control system with EMS bus control, Worcester intelligent wall mounted controls. ▶ Connect 2 core cable.

Table 14 Low voltage (signal cables) terminal strip for external accessories

Connecting the automatic filling (accessory)

- ▶ Flip down the control unit(→ Fig. 56).
- ▶ Plug cables to solenoid valve.



Cables are not polarity sensitive.

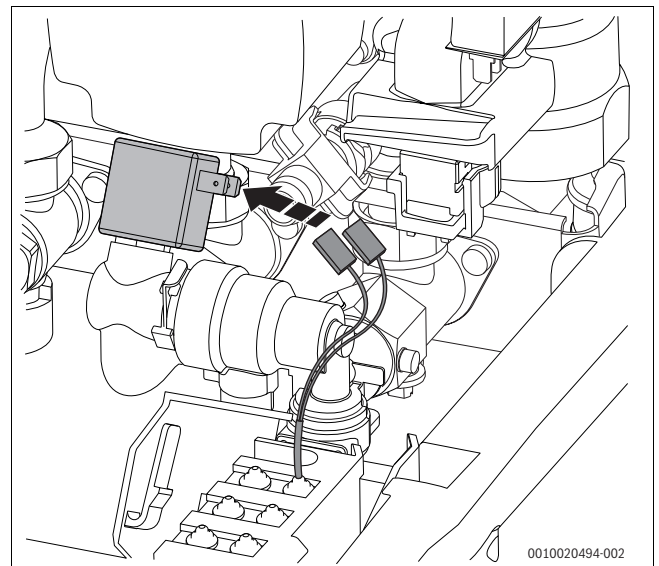

Fig. 60 Connecting the automatic filling facility

5.5.2 Cable preparations

NOTICE

Damage to control unit!

Small pieces of wire can cause shorts and damage to electronics.

- ▶ When stripping wires always ensure copper strands do not fall into the control box.

Power supply (power cables), example → figure 61

- ▶ Ensure the conductors (C) can reach the appropriate terminal connection and that the protective (earth) conductor is longer than the other wires.
 - Power cables connected to the appliance may have different conductor lengths depending on the termination point.

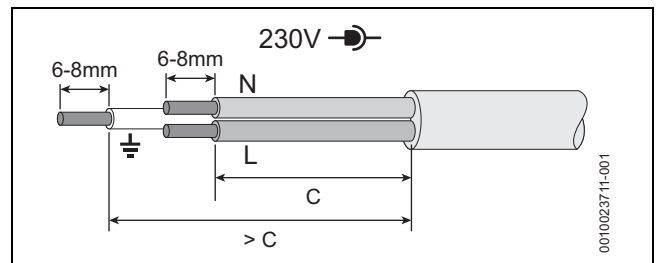

Fig. 61 Power supply (power cables) preparation

Low voltage (signal cables), example → figure 62

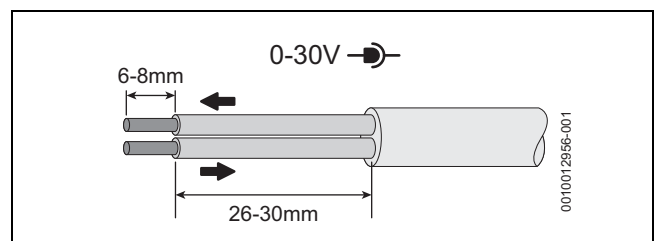

Fig. 62 Low voltage (signal cables) preparation

5.5.3 External controls - domestic installations

Appliance external control connections example



External 230V single channel timers:

- ▶ Leave DHW pre-wired link in place.
- ▶ The electrical power supply to the external equipment [2] is supplied from 230V OUT - L (Live), N (Neutral) and \perp (earth) terminals.
- ▶ The Switch Live from the external equipment [3]:
 - Heating/zone controls connects to \perp LR terminal, remove CH pre-wired link only.
 - Control for appliance Pre-heat function, optional. Hot water time controller connects to \perp LR terminal, remove pre-wired link (only use when a Worcester controller has been fitted that does not have DHW pre-heat time control available or no Worcester controller fitted).
- ▶ External frost thermostat connections [4]:
 - The Live supply is terminal FS
 - The Switch Live is terminal FR

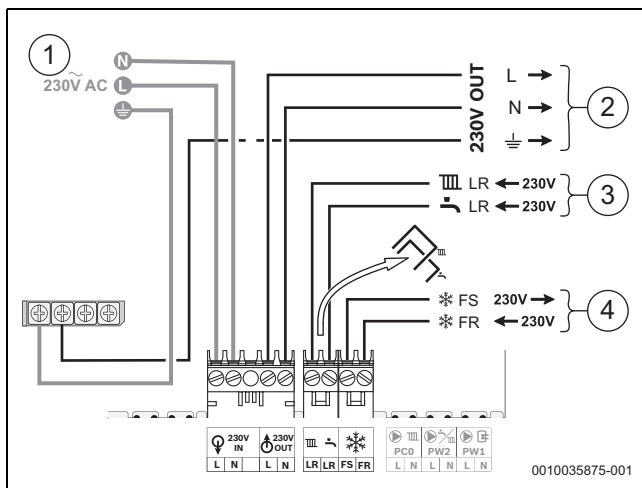

Fig. 63 External controls connections example

- [1] 230V mains supply to the appliance.
- [2] 230V supply from the appliance to the external controls.
- [3] CH & DHW Switch Live (Demand) from the external controls.
- [4] External frost protection Live supply and Switch Live (Demand).

6 Commissioning

6.1 Pre-Commissioning checks



DANGER

Risk of electric shock!

- ▶ Isolate electrical components from the power supply (230 V AC) (fuse, circuit breaker) and secure against unintentional re-connection before carrying out any work. Information on safe isolation can be found in the Health and Safety Executive guidance HSG85.
- ▶ Check for zero potential before proceeding with work, using test equipment approved to GS38 to confirm that the electricity supply is disconnected.

Checks before commissioning:

- ▶ Check that the service and water pipes are connected correctly.
- ▶ Check the gas type specified on the identification plate matches that of the gas supply and that the gas supply is properly purged.

- ▶ Check that the appliance is filled with water and under pressure (0.8 to 1.7 bar) and that there are no leaks.
- ▶ Check that the electrical connections of the appliance are correct:
 - Mains electrical supply - 230V, 50Hz
 - Compliant earth connection
 - Correct polarities.
 - External equipment and controls are wired in correctly.
- ▶ Check that the flue is correctly fitted, airtight, free from any obstruction and the connections are secure.
- ▶ Check that the condensate pipework is connected properly and that there are no leaks.

NOTICE

If the appliance is not to be commissioned immediately then, after successfully completing all of the checks and any rectification work:

- ▶ Isolate the electricity supply.
- ▶ Isolate the gas supply.
- ▶ Close the water shut-off valves to the appliance.
- ▶ Label appropriately.

6.2 Water treatment

Primary system flushing (Central Heating)

Ensure that the system has been cleaned:

- Following the guidance of BS 7593:
 - Code of Practice for treatment of water in hot water central heating systems.
- Overview available in Pre-installation, Cleaning primary systems section.

Inhibitor (Central Heating):

Add a suitable inhibitor that is compatible with aluminium (or combined inhibitor/anti-freeze, if the system is exposed to freezing conditions), to the heating system in accordance with the DWTA code of practice and manufacturer's guidelines.



The pH value of the system water must be between 6.5 and 8 or the appliance warranty will be invalidated.



The inhibitor or combined inhibitor/anti-freeze must not cause damage to the materials within the appliance (aluminium, mild steel, stainless steel, copper and brass) and any other materials/components within the system.

- ▶ Record the date when the inhibitor was added to the system on the guarantee card.
- ▶ The concentration level of inhibitor in the system should be checked every 12 months or sooner if system content is lost.

NOTICE

Sealing agents

Normally the addition of sealing agents to the system water is not permitted as this can cause problems with deposits left in the heat exchanger.

- ▶ In cases where all attempts to find a system micro leak have failed, Worcester, Bosch Group supports the use of Fernox F4 leak sealer.

6.2.1 Filling the appliance and adding Inhibitor



Before pressurising the system.

Additional expansion vessel fitted to the system.
The appliance integral expansion vessel is pre-charged to 0.75 bar. A Schrader type valve is fitted to the expansion vessel to allow for pressure adjustment if required.

- ▶ If an extra expansion vessel is fitted to the central heating system, ensure that it is set to the same pressure as the appliance internal expansion vessel, refer to separate instructions supplied with the extra expansion vessel.

Filling the system - Sealed systems

NOTICE

- ▶ Salt based softened water must not be used to fill the central heating system.
- ▶ Check drain cocks and manual air vents are closed and all radiator valves are open. Add a suitable inhibitor or combined inhibitor/anti-freeze, if the system is exposed to freezing conditions, to the heating system water in accordance with the manufacturers instructions.
- ▶ Turn on the water main and open the system valves.
- ▶ Fill the system to between 0.8 and 1.7 bar via a WRAS approved filling loop or one of the Integrated filling link accessories.
 - Refer to Integrated filling link accessory instructions for operation and use.
- ▶ The Automatic Air Vent will release any air trapped in the appliance.
- ▶ Manually vent all radiators, tighten when completed and check the system for any leaks and correct if required.
- ▶ Top up the system pressure if the pressure drops below 0.8 bar.
- ▶ Isolate and remove filling loop connections to the system.
 - Refer to Integrated filling link accessory instructions for any further actions required after filling the system.



Optional automatic filling link is available as an accessory. It can be used to fill the system.

- ▶ Integrated filling link is supplied with the appliance (→ overview, page 8).



Filling the system - When initially filling the appliance, before power is applied, use the pressure gauge to set the system pressure. Once the appliance electrical pre commissioning is complete and the appliance is switched on refer to the digital pressure display on the appliance.



The analogue pressure gauge within the appliance is for indication purposes only, and is intended to assist when initially filling the system. Pressure shown on this gauge should not be compared to readings shown on the digital display as they will differ, especially when the circulation pump is running. Final adjustments to system pressure must be made whilst referring to the digital pressure display.

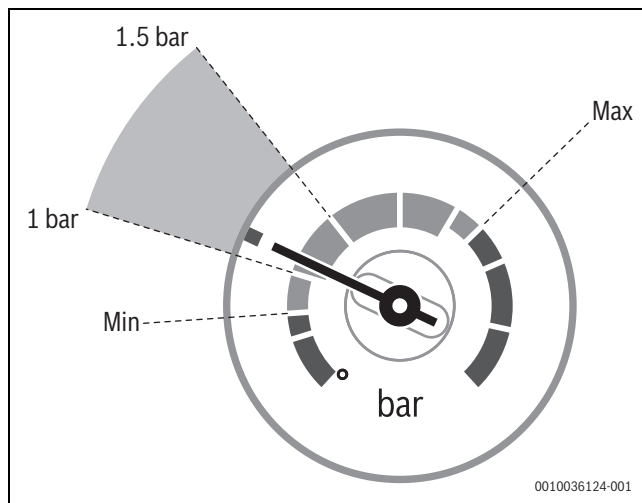

Fig. 64

Integral keyless filling link

Locate the filling link and follow the instructions for re-pressurising the system.

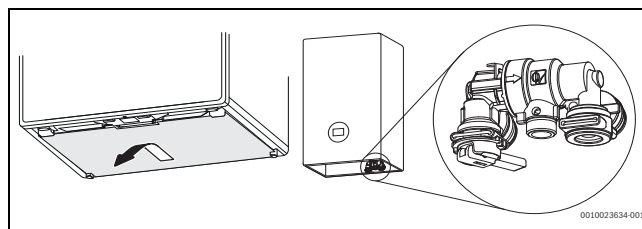

Fig. 65 Enable access to keyless filling link

- ▶ Re-pressurise the system.
 - Pull the lever [1] down to start the filling process.
 - The pressure indicator on the pressure display will start to move towards the green bar.
- ▶ When the pressure indicator reaches the middle of the green bar [2] and the pressure is between 1 and 1.5 bar
 - Release the lever [1] to stop the filling process.
- ▶ Top up the system pressure, if as a result of the air bleeding the pressure drops off.

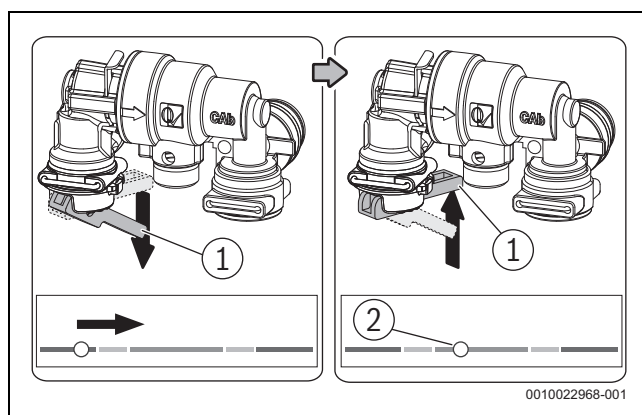

Fig. 66



If the indicator is on the right hand side red pressure zone as a result of over filling:

- ▶ Bleed one radiator until the pressure indicator returns to the green bar.

6.2.2 Adjusting the operating pressure of the heating system

Pressure shown on the digital display	
1 bar	Minimum charge pressure (when system is cold)
1 - 1.5 bar	Optimal charge pressure
3 bar	Maximum charge pressure at maximum heating water temperature must not be exceeded (pressure relief valve opens).

Table 15

If the displayed pressure is below 1 bar when the system is cold:

- ▶ Top up the water until the indicator is between 1 bar and 1.5 bar again.

If pressure is not being maintained:

- ▶ Check tightness of expansion vessel and heating system.

6.3 Starting the appliance

NOTICE

Damage to appliance or system!

Running the appliance:

- ▶ Never run the appliance when the appliance/system is empty or partially filled.

6.3.1 Control panel overview

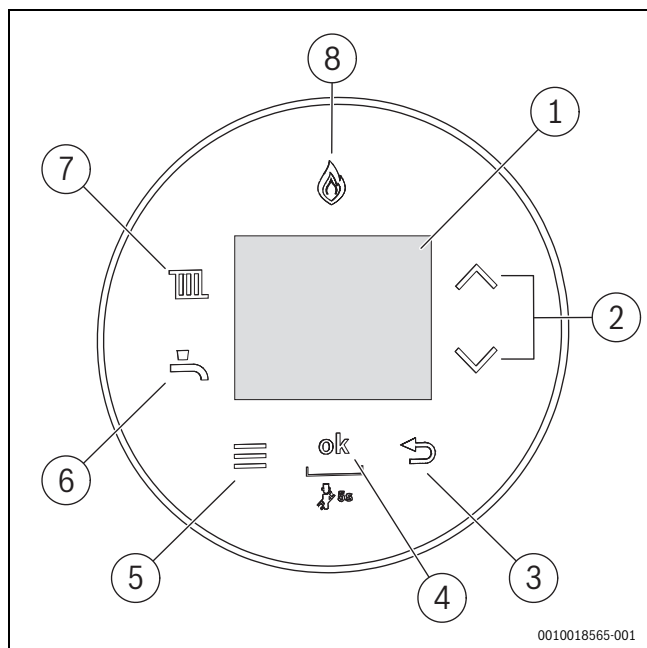

Fig. 67 Control panel

- [1] Display
- [2] ▲ and ▼ keys: To navigate through menus and increase/decrease settings
- [3] ↵ key: Return/back
- [4] ok key: Save settings, Chimney sweeper key: press 5 s for chimney sweeper mode
- [5] Menu key
- [6] Hot water key: Hot water mode on/off, adjusting the hot water temperature
- [7] Heating key: Heating mode on/off, set the maximum flow temperature
- [8] Burner display: Illuminates when the burner is alight.



See the operating instructions for a description of the user menus.

6.3.2 Turn on the appliance

Set the language the first time the appliance is turned on.

- ▶ To scroll through the languages, press the ▲ or the ▼ key.
- ▶ To select the desired language, press the **ok** key.



When the display shows **Siphon fill. prog.**, the siphon filling program is active. The condensate siphon in the appliance is filled (→ chapter 6.3.3).

Detailed operating settings



Appliance operation

- ▶ Refer to Operating Instructions for full details on setting the CH flow temperature, DHW temperature set point and the operating settings menu information.



WARNING

Risk of scalding!

- ▶ This appliance is supplied with the CH control set at approximately 65 °C, a temperature that should be suitable for most installations that comply with current Building Regulations. When the boiler switches from CH to DHW, the temperature of the hot water may briefly exceed the DHW set point if the CH temperature is set higher than the DHW temperature. If the CH temperature is changed to above 65 °C, it is advisable to fit a thermostatic mixing valve (TMV) at the point of use (e.g. before the bath hot tap or shower) to protect vulnerable people from scalding.

6.3.3 Siphon filling mode

The siphon filling mode is activated automatically or manually by the installer on the appliance in the menu settings. The siphon filling mode is activated in the service menu under **> Settings > Special function > Siphon fill mode**.

While the siphon filling mode is active, access to the **Hot water** menu, the **Heating** menu and the service menu is possible.

The siphon filling mode is activated automatically in the following cases:

- The appliance is switched on using the fuse spur.
- The burner was not in use for at least 28 days.
- After conversion from summer to winter mode.

The next time there is a heat requirement for heating, the appliance is held at low thermal output for 15 minutes. The siphon filling mode remains active until the appliance has completed 15 minutes of operation with increased min. capacity.

During the siphon filling program, **Siphon fill. prog.** appears on the display.

The siphon filling mode is interrupted when the chimney sweep mode is started.

6.4 Chimney sweep mode



You have 30 minutes to take your measurements or to make your settings. After this time the appliance returns to normal operation. When running in the chimney sweep mode, the appliance will operate both the central heating and the domestic hot water circuits. This is to allow sufficient time for this part of the commissioning procedure. It will be necessary to run water through the domestic hot water circuit to ensure that the appliance will not overheat whilst in chimney sweep mode.

In chimney sweep mode the rated output of the appliance can be selected.

- ▶ Press the **ok** key when the countdown is completed and **Chimney sweep** is displayed.
- ▶ Confirm the query with **Yes**.
- ▶ Set the desired rated output using the **▲** or the **▼** keys. The value is accepted after 2 seconds and marked with a tick.
- ▶ To exit the chimney sweep mode, press the **ok** key or the **↶** key.

Adjustment with casing removed in chimney sweep mode

1. Set the chimney sweep mode and start up the appliance at maximum rated output.
2. Set the chimney sweep mode and set the appliance at minimum rated output.

6.5 Combustion casing removal

- ▶ Remove the combustion cover.

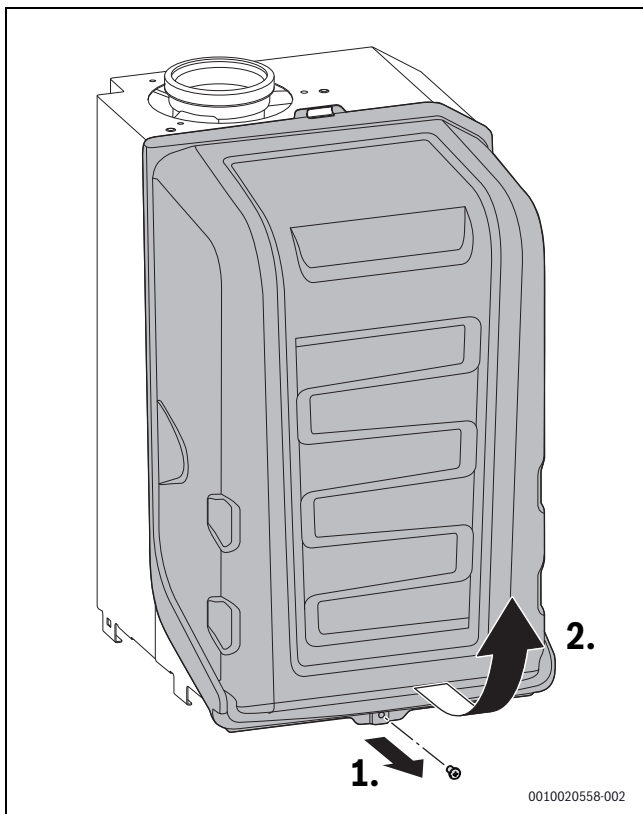

Fig. 68 Removing the combustion cover

6.6 Checking gas inlet pressure

6.6.1 Checking the gas supply pressure

- ▶ Switch off the appliance and close the gas isolator.
- ▶ Unscrew the screw on the test point for the gas supply pressure and connect a pressure gauge.

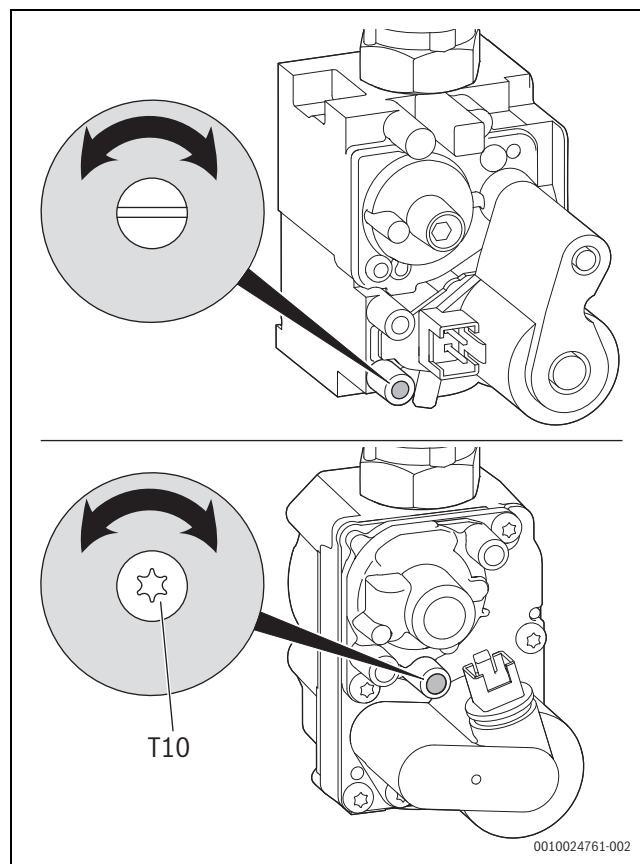

Fig. 69 Gas valve test points (above: SIT valve, below: Honeywell valve)

- ▶ Open the gas isolator and switch on the appliance.
- ▶ Ensure that there is heat transfer by opening the radiator valves and zone valves.
- ▶ Set the chimney sweep mode and start up the appliance at maximum rated output.
- ▶ Check the required gas supply pressure according to table 16.



Commissioning must not take place outside of the permissible pressure range.

- ▶ Identify the cause and rectify the fault.
 - ▶ If this is not possible: isolate the appliance on the gas side and notify the gas supplier.
-
- ▶ Exit the chimney sweep mode.
 - ▶ Switch off the appliance, close the gas isolator, remove the pressure gauge and tighten the screw.

- ▶ Check for gas tightness.

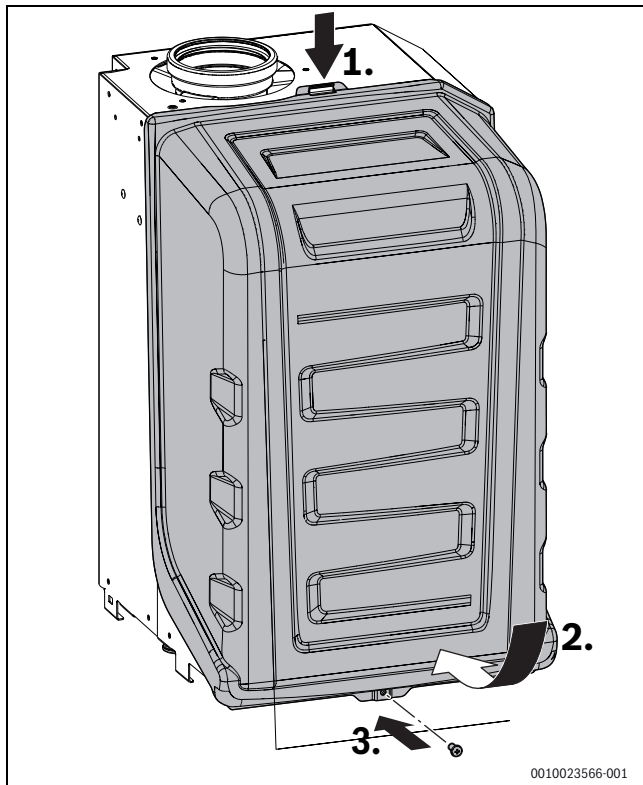

Fig. 70 Refit combustion casing

- ▶ Refit the combustion casing.
- ▶ Ensure this cover is engaged onto top bracket [1] before securing screw [3].

Gas pressure within the system

i The appliance must be running at maximum output rate when performing the gas rate check (→ chapter 6.4).

i Combi appliances

- ▶ Running a hot water tap does not guarantee the boiler will operate at maximum output throughout the test.

Refer to the figures below for natural gas or LPG gas pressures. The pressure drop from the meter or at the LPG gas supply to the gas valve inlet test point must not be more than:

- 40 kW or below (≤ 40 kW): 2.5 mbar for Natural Gas
- above 40 kW (> 40 kW): 3.5 mbar for Natural Gas
- 4 mbar for LPG

Meter/ LPG supply	Allowed mbar pressure drop			
	Across pipe work	Appliance inlet	Across appliance	Gas valve
Natural Gas				
19–23	1	18–22	≤ 40 kW: 1.5 > 40 kW: 2.5	≤ 40 kW: 16.5–20.5 > 40 kW: 15.5–19.5
LPG				
32–45	2.5	29.5–42.5	≤ 40 kW: 1.5 > 40 kW: 2.5	≤ 40 kW: 28–41 > 40 kW: 27–40
mbar range				

Table 16

If the pressure drops are greater than shown below, then this would indicate a problem with the pipe work or connections within the system.

NOTICE

Do not continue commissioning until the correct gas pressure is achieved.

Gas supply pressure drop

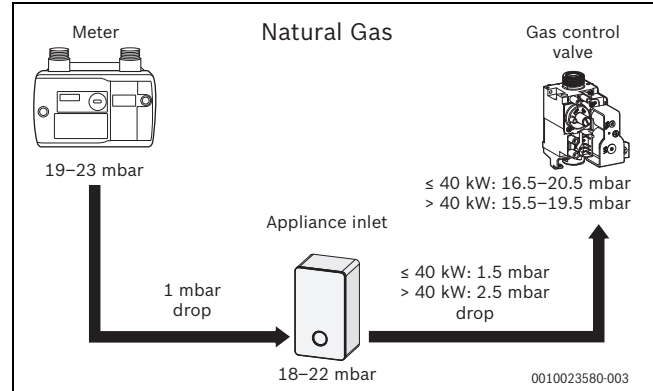

Fig. 71 Natural Gas pressures

≤ 40 kW	> 40 kW
GR8700iW 30 C	GR8700iW 40 C
GR8700iW 35 C	GR8700iW 45 C
	GR8700iW 50 C

Table 17 Pressure drop NG

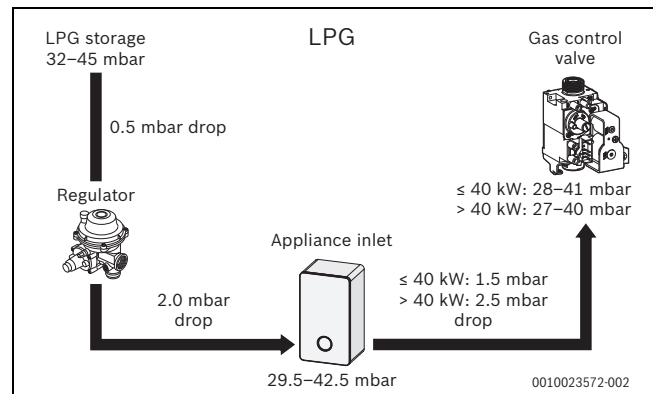

Fig. 72 LPG pressures

≤ 40 kW	> 40 kW
GR8700iW 30 C	GR8700iW 40 C
GR8700iW 35 C	GR8700iW 45 C
	GR8700iW 50 C

Table 18 Pressure drop LPG

6.7 Checking the gas rate



The appliance must be running at maximum output rate when performing the gas rate check, (→ chapter 6.4).

- ▶ The gas rate should be measured at the gas meter after the appliance has been operating for **a minimum of 10 minutes** at maximum output.
- ▶ Refer to Technical data section of this manual for the appliance gas rates and CO/CO₂ ratios.
- ▶ Where a gas meter is not available (e.g. LPG) the CO/CO₂ must be checked.
- ▶ Gas rate must be checked with the appliance in service, maximum output test mode.
- ▶ Carry out gas rating as per the latest advice in the Gas Safety (Installation and Use) Regulations.
- ▶ Ensure all other gas appliances are isolated when carrying out the gas rate check on the appliance.
- ▶ Set the chimney sweep mode and start up the appliance at maximum rated output.
- ▶ Where a gas meter is not available (e.g. LPG) the CO/CO₂ must be checked to the units shown in the setting of the air/gas ratio.
- ▶ If pressure and gas rate are satisfactory press the **ok** key or the **↔** key and the boiler will return to normal operation.

6.8 Checking for gas leaks during operation

- ▶ Use an approved gas sniffer or leak detection fluid to check all connections for possible leaks. Leak detection fluid must be certified as a gas leak testing agent.
- ▶ Do not allow leak detection fluid to come into contact with the electrical components.

6.9 CO and combustion check

The following combustion and flue integrity checks are mandatory and these values must be recorded on the Benchmark check list, at the end of these instructions.

Once the gas rate and pressure have been confirmed as acceptable then the CO and combustion checks can be undertaken.

The flow chart is given for guidance, the details of the checks are given in the following sections:

- Checking flue integrity (→ chapter 6.10).
- Flue gas analysis (→ chapter 6.11).

NOTICE

Before CO and combustion checks:

- ▶ Verify the appliance is connected to the correct gas type.
- ▶ Ensure the appliance is supplied with the correct gas inlet pressure and gas rate as specified previously in the Commissioning section.
- ▶ Visually check the integrity of the whole flue system and confirm that all the components are correctly assembled, fixed and supported.
- ▶ The flue gas analyser must be the correct type as specified in BS 7967. Before use the analyser must have been calibrated as specified by the manufacturer. The installer must be competent in the use of the analyser.
- ▶ Check and zero the analyser in fresh air as specified by the manufacturer.
- ▶ The air/gas ratio valve is factory set and must not be adjusted during commissioning unless this action is recommended following contact with the Worcester, Bosch Group help line 0330 123 3366.

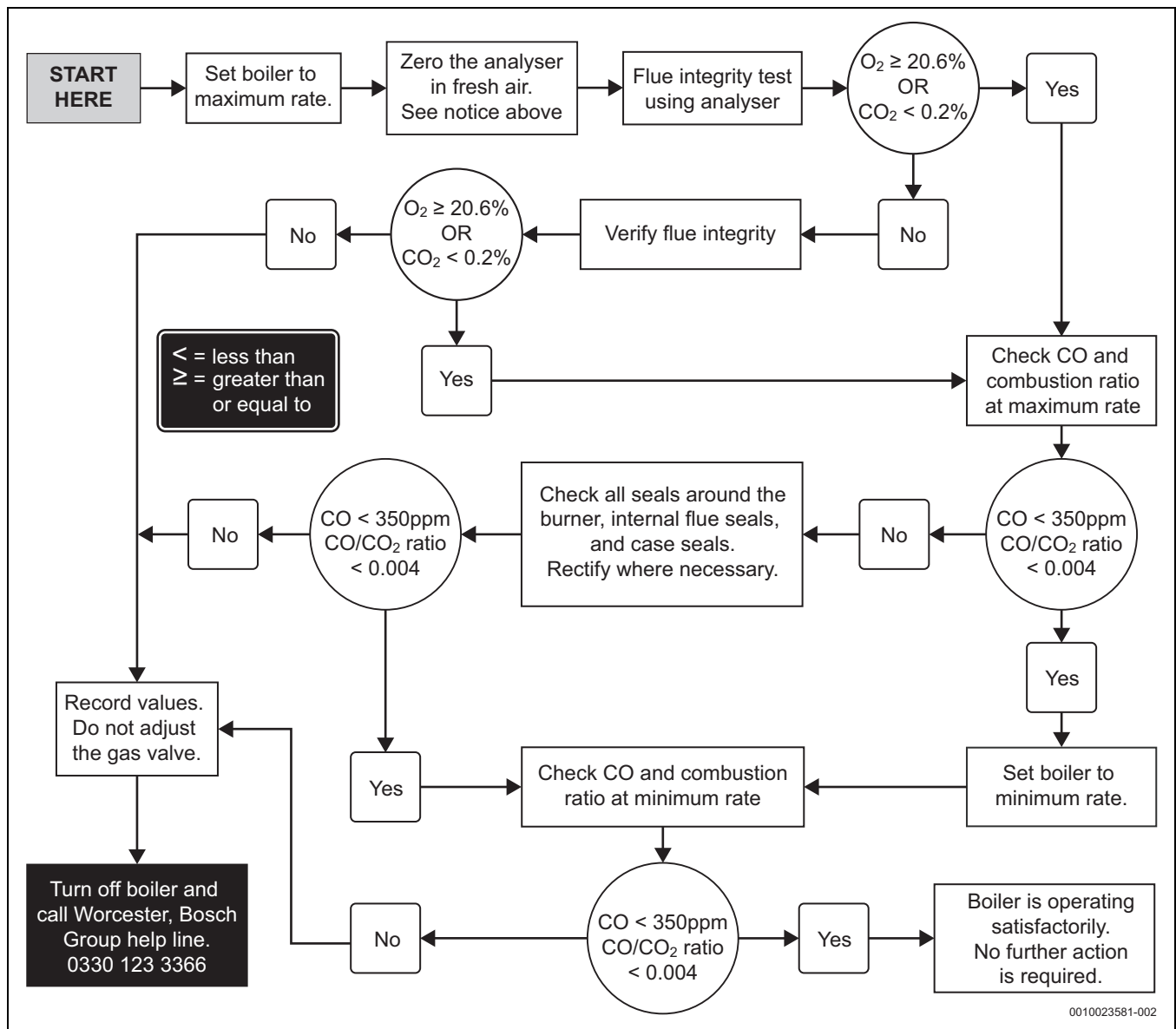

Fig. 73 Commissioning checks flow chart

6.10 Checking flue integrity



Flue integrity check

- ▶ The combustion casing must be fitted whilst this test is carried out.
- ▶ Refit the test point plugs after the test has been completed.

The integrity of the flue system and performance of the appliance can be checked via the flue turret/adaptor sample points.

Air inlet sample point location on flue turret/adaptor.

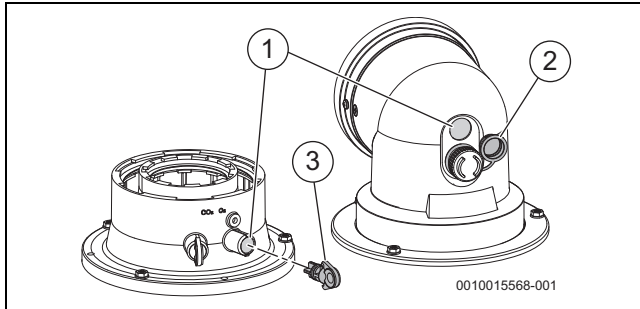

Fig. 74 Flue integrity check test point

- [1] Air inlet sample point
- [2] Flue turret air inlet blank plug (with retaining ring)
- [3] Flue adaptor air inlet blank plug

- ▶ With the appliance combustion casing on and the appliance running at maximum output in chimney sweep mode (→ chapter 6.4 "Chimney sweep mode"), remove the blanking plug [2 or 3] for the air inlet sample point [1].
- ▶ Insert the analyser probe into the air inlet sample point [1].
- ▶ Allow the readings to stabilise and check that:
 - O₂ is equal to, or greater than 20.6%
 - CO₂ is less than 0.2%
- ▶ If the readings are outside these limits then this indicates that there is a problem with the flue system or combustion circuit.

6.11 Flue gas analysis

NOTICE

Combustion testing

- ▶ Combustion testing must be carried out by a competent qualified person. Testing must not be attempted unless the person carrying out the combustion check is equipped with a calibrated Flue Gas Analyser conforming to BS 7967 and is competent in its use.



Flue gas analysis

- ▶ Ensure that the gas inlet pressure has been checked and is satisfactory.
- ▶ Refit the test point plugs after the test has been completed.

The flue gas analysis performance of the appliance can be checked via the flue turret/adaptor sample points.

Refer to figure 75 for the location of the flue gas sample point on flue turret/adaptor.

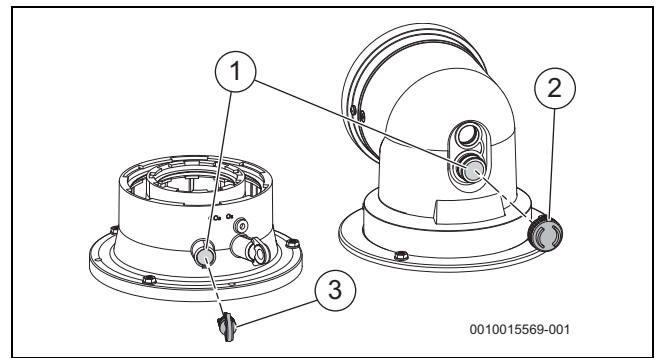

Fig. 75 Combustion test

- [1] Flue gas sample point
- [2] Flue turret flue gas blank plug
- [3] Flue adaptor flue gas blank plug

The CO and combustion ratio are checked;

- In chimney sweep mode at maximum output.
- In chimney sweep mode at minimum output.

Appliance to maximum output

- ▶ Set the appliance running at maximum output in chimney sweep mode (→ chapter 6.4 "Chimney sweep mode").

Appliance to minimum output

- ▶ Set the appliance running at minimum output in chimney sweep mode (→ chapter 6.4 "Chimney sweep mode").
 - Allow the appliance to stabilise at minimum output.

Measuring the CO and combustion ratio.

- ▶ Remove the blanking plug [2 or 3] for the flue gas sample point [1].
- ▶ Insert the analyser probe into the flue gas sample point [1].
 - Ensure that the probe reaches the centre of the flue gas exhaust, adjust the cone on the probe so that it seals the sample point and correctly positions the end of the probe.
- ▶ Check the CO and combustion readings.

6.12 Range rating the appliance

The maximum heat output of this boiler can be adjusted to suit the exact requirements of the building. The process of adjusting the maximum heat output is commonly referred to as range rating. The new boiler is set at the maximum output and should be adjusted when it is installed and commissioned. In accordance with the standards, the declared space heating efficiency, useful efficiency and NO_x values efficiency for this range rated boiler are not measured at the maximum output. To achieve the published efficiency and NO_x values, the gas rate should be reduced (→ chapter 7.2.3, menu item Max. heat output, page 57).

6.13 Finishing commissioning

6.13.1 Fitting the appliance casing



The front casing is to be secured at the bottom with one screw (as supplied) against unauthorised removal (electrical safety).

- ▶ Always secure the casing with this screw.



- ▶ Remove the protective films from the boiler display before handing over to the user.

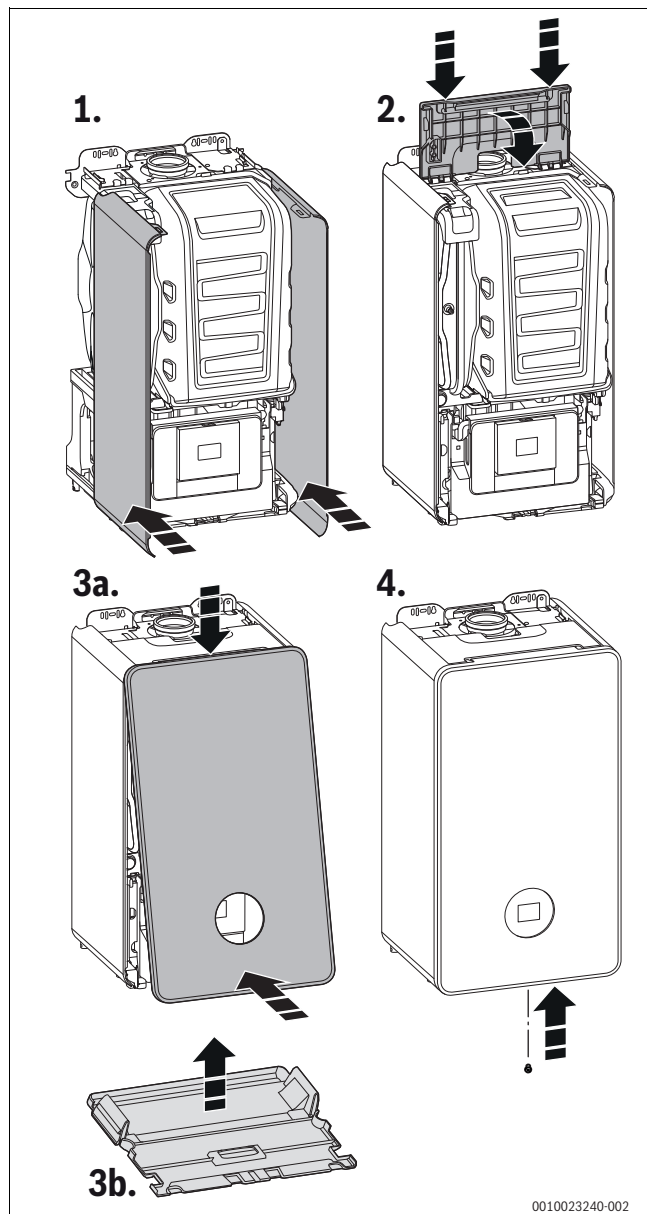

Fig. 76 Fitting the appliance casing

- [1] side covers
- [2] top
- [3] front
- [4] bottom



At the time of commissioning, complete all relevant sections of the Benchmark Checklist located in the Technical Specifications/Logs section of this document.

Appliance handover:

- ▶ Complete the Benchmark Gas Boiler Commissioning Checklist.
- ▶ Show the customer the special features of the appliance.
- ▶ Show the customer the efficiency tips in the User Instructions.
- ▶ Set up the appliance controls and show the customer how to operate all the control unit/s for central heating and DHW operation.
 - Also show where in the appliance/controls documentation where this information can be found.
- ▶ Where applicable, instruct the customer on:
 - how to check the system pressure and re-pressurise if necessary.
 - how to set the TRVs.
 - how to reset the appliance.
- ▶ Show the customer the fault finding section in the User Instructions.
- ▶ Show the customer where the serial number/appliance information is located, they will need this information if they call in with a problem (Benchmark Commissioning checklist on page 92 contains all relevant appliance information).
- ▶ Give the customer details of how to contact the installer/ gas emergency numbers.
- ▶ Show the customer how to safely isolate the appliance.
- ▶ Advise the customer where they can find information on the Worcester, Bosch Group website www.worcester-bosch.co.uk.
- ▶ Ensure that all documentation, is left with the appliance or homeowner.
 - Appliance documentation.
 - Controls documentation.
 - Any other equipment documentation that is connected to the appliance or system.
- ▶ Appliance not in use
 - If the appliance is not going to be used immediately and may be exposed to freezing conditions, advise the customer of the precautions necessary to prevent damage to the appliance, system and building.
 - If the appliance is unused and exposed to freezing conditions, safely isolate all the mains supplies and drain the system and appliance, label accordingly.
- ▶ Show the customer the location of the condensate pipe run in unheated or external areas that may be at risk of freezing during prolonged cold spells.
- ▶ **User recommendation:**
 - Advise the user to have the appliance and heating system thoroughly serviced annually by a competent, registered gas engineer, such as a Gas Safe registered engineer or British Gas engineer. In the Republic of Ireland servicing work must be carried out by a Registered Gas Installer (RGI).
 - Present, where relevant, maintenance aids and reminders within the appliance menus.
 - Arrange an inspection/maintenance contract with an approved heating contractor.

6.13.2 Appliance/product guarantee

This appliance/product has a guarantee against faulty materials or workmanship for a period from the date of installation subject to the terms and conditions.

For full terms and conditions, please visit:

www.worcester-bosch.co.uk/guarantee-terms-and-conditions

Guarantee registration

Your appliance/product carries a guarantee against faulty material or manufacture subject to Terms and Conditions.

To read the full Terms & Conditions please visit us on-line at www.worcester-bosch.co.uk/guarantee.

Your statutory rights are not affected by the manufacturer's guarantee



7 Settings in the service menu

Many appliance functions can be set and checked in the service menu. It includes:

- **Info:** viewing information
- **Settings:** general and appliance-specific settings
- **Function check:** settings for function checks and start of function checks
- **Reset:** restoring the factory settings, resetting the maintenance intervals
- **Demo mode:** mode for testing and demonstrating the functions. Power off appliance for exit.

7.1 Operating the service menu

Opening the service menu

- ▶ Press the  key and the  key simultaneously until the service menu appears.



Closing the service menu

- ▶ Press the  key or the  key.



-or-

- ▶ Press the  key.

Navigating through the menu

- ▶ To highlight a menu or a menu item, press the  key or the  key.
- ▶ Press the **ok** key.
The menu or the menu item is displayed.
- ▶ To return to the next higher menu level, press the  key.

Changing the setting values

- ▶ Select the menu item with the **ok** key.
- ▶ To select the desired value, press the  or the  key.
- ▶ Press the **ok** key.
The new value is saved.

Exiting the menu item without saving values

- ▶ Press the  key.
The value is not saved.

7.2 Service menu

7.2.1 Overview of the service menu

Benchmark

- Flow temp.
- DHW flow rate
- Hot water temp.

Info

- Current status
- Current fault
- Fault history
- Boiler
 - Max. heat output
 - Flow temp.
 - Set flow temp.
 - Low-loss hdr.tmp
 - Heating mod.
 - Act. burner mod.
 - Burner output
 - Ionisation current
 - Pump mod.
 - Outside temp.
 - HC1 pump
 - Burner starts
 - Hours run
 - System pressure
- Hot water
 - Max. output
 - DHW flow rate
 - DHW act. temp.
 - Hot water temp.
 - Inlet temp.¹⁾
 - DHW set temp.
- Autom. filling
 - System pressure
 - Last refill dur.
 - Status
 - Refilling active
- System
 - Contr.device ver.
 - Progr. unit ver.
 - SW sub-ver.
 - Code plug no.
 - Code plug ver.
 - Key¹⁾
- Solar
 - Collector temp.
 - Cyl.temp.bottom
 - Collector pump
 - Solar fault

Settings

- Hydraulics
 - Low-loss header
 - DHW configuration
 - HC1 configuration
 - Pump config.
- Heating
 - Mx.heat.outp %
 - Standby time
 - Anticyc. temp. off
 - Anticycle temp. on
- Hot water
 - Turbine signal del.
 - DHW start del.
 - CH delay
 - Man. TD line
 - TD-Temperature
 - Max. TD duration
- Pump
 - Pump range map
 - Pump ctr. mode
 - Min. output
 - Max. output
 - Pump overrun
 - Min.syst.pressure
 - Target pressure
- Special function
 - Ventilation func.
 - Siphon fill. prog.
 - 3-WV mid. pos.
 - Filling valve avail.
 - Start filling
 - Autom. filling
 - Min. Sys. Pres.
 - Target Sys. Pres.
 - Max. refill time
 - Htg. sys.type
 - Reset refilling
- Maintenance
 - Maintenance type
 - Without
 - Boiler run time
 - Burner run time
 - Service date²⁾
 - Landlord¹⁾
 - End date
 - Maint. reminder
 - Installer tel. no.
- Limit values
 - Max. flow temp.
 - Max. DHW temp.
 - Min. boiler outp.

1) Only with solar accessory kit

2) Only available with installed Key Timer (accessory)

- Heating curve
 - Enable
 - Htg. curve base
 - Htg. curve end
 - Summer mode
 - Frost prot.
 - Frost temp. limit
 - Solar
 - Max. solar temp.
 - Solar pump type
 - Start solar system
-

Function check

- Activate test
 - Burner
 - Ignition
 - Fan
 - Pump
 - 3-way valve
 - HC1 pump
 - Ionisat. oscill.
 - Solar pump
-

Reset

- Default setting
 - Fault history
 - Hidden menu: Reset Maintenance Landlord
-

Demo mode

7.2.2 Benchmark and Info menu

Menu item	Comment/restriction
Flow temp.	Flow temperature in °C
DHW flow rate	Hot water flow rate in l/min
Hot water temp.	Outlet temperature in °C

Table 19 Benchmark menu

Menu item	Comment/restriction
Current status	
Current fault	→ Tab. 10.1.2, page 74
Fault history	
Boiler	
Max. heat output	Max. heating output in kW
Flow temp.	Flow temperature in °C
Set flow temp.	Setting value of the flow temperature
Low-loss hdr.tmp	Only if installed. Momentary flow temperature in low loss header in °C
Heating mod.	Burner modulation (heating) in %
Act. burner mod.	
Burner output	Current burner output in kW
Ionisation current	Current ionisation current in µA
Pump mod.	Actual system pump modulation in %
Outside temp.	Current outside temperature in °C
HC1 pump	Current status on/off
Burner starts	Number of burner starts since commissioning
Hours run	Elapsed time of the system since commissioning
System pressure	Current system pressure in bar
Hot water	
Max. output	Max. hot water output in kW
DHW flow rate	Current hot water flow rate in l/min
DHW act. temp.	Actual hot water temperature in °C
Hot water temp.	Current water temperature in °C
DHW set temp.	Setting value of the hot water temperature
System Fill	
System pressure	Current system pressure in bar
Last refill dur.	Duration of last refill
Status	There are two stages: ready and not ready
Refilling active	Automatic filling on
System	
Contr.device ver.	Software version of the control unit
Progr. unit ver.	Software version of the control unit
Code plug no.	Coding plug number
Code plug ver.	Coding plug version
Key	Type of installed key, e.g. "Connect-Key"
Solar	
Collector temp.	Collector temperature
Cyl.temp.bottom	Cylinder temperature at bottom
Collector pump	Collector pump
Solar fault	Current faults

Table 20 Info menu

7.2.3 Settings menu

The menu is adapted to your system automatically. Some menu items are only available if the system has been set up accordingly. The menu items are only displayed in systems in which the corresponding system components are installed, e.g. automatic filling facility or Key Timer.



The factory settings are **highlighted** in the following table.

Menu item	Settings/adjustment range	Comment/restriction
Hydraulics		
Low-loss header	<ul style="list-style-type: none"> Low loss header not installed in the system Low loss header installed, temperature sensor connected to the wall mounted boiler Low loss header installed, temperature sensor connected to the heating circuit module Low loss header installed, but no temperature sensor is connected 	Position of the low loss header temperature sensor
DHW configuration	<ul style="list-style-type: none"> Not installed 3-way valve installed System?: Cyl. prim. pump inst. after low loss hdr. System?: Cyl. primary pump installed 	
HC1 configuration	<ul style="list-style-type: none"> No heating circuit 1 (HK1) on the appliance (HK1 not available or not connected via the heating circuit module) No own pump (flow rate for HK1 is realised by the heating pump) Own HC1 pump downstream the low loss header Dedicated pump installed 	
Pump config.	<ul style="list-style-type: none"> None Heating pump 	
Heating		
Max. heat output (range rating)	<ul style="list-style-type: none"> 30 kW: 50 ... 55* ... 100% 35 kW: 50 ... 58* ... 100% 40 kW: 42 ... 49* ... 84% 45 kW: 40 ... 47* ... 79% 50 kW: 35 ... 42* ... 70% [*] Range rated	Maximum released heating output [%]. Reducing the output increases the efficiency and reduces NO _x emissions. On natural gas appliances: <ul style="list-style-type: none"> ▶ Measure the gas rate. ▶ Compare the measurement with the setting tables (→ chapter Technical data, page 83 and chapter 12.6, page 88. ▶ Correct deviations.
Standby time	<ul style="list-style-type: none"> 3 ... 5 ... 60 min 	The time interval determines the minimum delay between starting and restarting the burner.
Anticyc. temp. off	<ul style="list-style-type: none"> 2 ... 6 ... 15 K 	Temperature standby period.
Anticycle temp. on	<ul style="list-style-type: none"> -15 ... -6 ... -2 K 	The difference between the current flow temperature and the set flow temperature until the burner is switched on or off.
Hot water		
Turbine signal del.	<ul style="list-style-type: none"> 0.50 ... 4.00 s 	The delay prevents sudden changes in the water supply pressure from causing the burner to briefly operate although no water is drawn off.
DHW start del.	<ul style="list-style-type: none"> 0 ... 50 s 	The delay concerns heating operation in systems in which the DHW outlet of the solar-heated DHW cylinder is connected to the cold water inlet of a combi boiler. DHW heating by the combi boiler will be suppressed expecting that solar thermal DHW will reach the hot water temperature sensor prior eliminating the need to run the boiler. This avoids unnecessary operation of the combi boiler. Set the heating delay in accordance with system conditions.
CH delay	<ul style="list-style-type: none"> 0 ... 1 ... 30 min 	The heating mode is disabled for this period of time following DHW heating.

Menu item	Settings/adjustment range	Comment/restriction
Man. TD line	<ul style="list-style-type: none"> On Off 	
TD-Temperature	<ul style="list-style-type: none"> 60 ... 70 ... 80 	
Max. TD duration	<ul style="list-style-type: none"> 10 ... 30 min 	
Pump		
Pump range map	<ul style="list-style-type: none"> Output dependent 0: pump rate proportional to thermal output Delta-P dependent 1: constant pressure 150 mbar Delta-P dependent 2: constant pressure 200 mbar Delta-P dependent 3: constant pressure 250 mbar Delta-P dependent 4: constant pressure 300 mbar Delta-P dependent 5: constant pressure 350 mbar Delta-P dependent 6: constant pressure 400 mbar 	<ul style="list-style-type: none"> ► Set low pump curve to save energy and avoid possible flow noise (→ chapter 12.5, page 87)
Pump ctr. mode	<ul style="list-style-type: none"> Energy saving Heat demand 	<ul style="list-style-type: none"> Saving energy: intelligent heating pump stop in heating systems with weather-compensated controller. The heating pump is only switched on when needed. In case of a heat requirement: the flow temperature controller switches the heating pump. When there is a heat energy demand, the heating pump starts up with the burner.
Min. output	<ul style="list-style-type: none"> 10 ... 100% 	Pump rate at minimum thermal output. Only available with pump characteristic map 0.
Max. output	<ul style="list-style-type: none"> 10 ... 100% 	Pump rate at maximum thermal output. Only available with pump characteristic map 0.
Pump overrun	<ul style="list-style-type: none"> 1 ... 2 ... 60 min 24 h 	Run-on time of the heating pump: pump run-on time begins at the end of the heat requirement.
Special function		
Ventilation func.	<ul style="list-style-type: none"> Off Auto On 	<p>The ventilation function can be activated after maintenance.</p> <p>During ventilation, the following appears in the info area of the standard display Ventilation func.</p>
Siphon fill. prog.	<ul style="list-style-type: none"> Off (only permissible during maintenance) On, boiler min. On, heating min. 	<p>The siphon filling program is activated in the following cases:</p> <ul style="list-style-type: none"> On, boiler min.: the appliance is being switched on. On, heating min.: The burner was not in use for at least 28 days. The operating mode is switched from summer to winter mode. <p>The next time there is a heat requirement for heating, the appliance is held at low output for 15 minutes. The siphon filling program remains active until the appliance has completed 15 minutes of operation at low output.</p> <p>During the siphon filling program the following appears in the info area of the standard display Siphon fill. prog.</p>
3-WV mid. pos.	<ul style="list-style-type: none"> No Yes 	The function ensures that the system is fully drained and that the motor can be easily removed. The 3-way valve remains at the centre position for approx. 15 minutes.
Filling valve avail.	<ul style="list-style-type: none"> No Yes 	
Start filling (only available when "Autom. filling" is "Yes" and filling valve is blocked)	<ul style="list-style-type: none"> No Yes 	

Menu item	Settings/adjustment range	Comment/restriction
Autom. filling (only available when "Filling valve avail." is "Yes")	<ul style="list-style-type: none"> • No • Yes • Min. Sys. Pres.: 0.5...0.7...0.8 bar • Target Sys. Pres.: 1.0 ... 1.7 bar • Max. refill time: 120 ... 240 s • Htg. sys.type Small/Medium/Large¹⁾ • Reset refilling No/Yes 	<p>The automatic filling function ensures that the operating pressure is maintained. If the operating pressure drops below the set value, the filling valve opens until the set set pressure is reached.</p> <p>To protect against leakage e.g., the filling valve closes in the following cases:</p> <ul style="list-style-type: none"> • No pressure increase can be measured. • The set filling time is exceeded.
Maintenance		
Maintenance type	<ul style="list-style-type: none"> • Without • Burner run time • Boiler run time • Service date • Landlord 	<p>Landlord:</p> <p>This menu item allows a date to be set for annual service/maintenance (End date). The service display appears as a reminder 30 days before the scheduled date. A contact telephone number (Installer tel. no.) is shown together with service display. The tenant should call this number to arrange a suitable maintenance date. A second reminder appears at the scheduled date. If the service display is not reset by the service engineer, the control unit limits the functions 14 days after the scheduled date.</p> <p>Reduced functions are set at Maint. reminder:</p> <ul style="list-style-type: none"> • DHW reduced: reduced comfort (max. 35 °C flow temperature) • Boiler off: central heating and hot water functions are set off.
Limit values		
Max. flow temp.	• 30 ... 88 °C	Limits the adjustment range for the flow temperature.
Max. DHW temp.	• 30 ... 60 °C	Limits the adjustment range for the hot water temperature.
Min. boiler outp.	• " Minimum rated output " ... "maximum rated output"	Minimum heat output
Heating curve		
Enable	<ul style="list-style-type: none"> • Off • On 	When connecting a weather-compensated control unit, no adjustment to the appliance is required. The system control unit optimises this setting. This service function activates a simple, weather-compensated controller with a linear heating curve. Depending on the on/off input, the heating is switched on or off.
Htg. curve base	• 20 ... 90 °C	This is only displayed if the controller was activated. This can be used to set the base point of the heating curve, which corresponds to a outside temperature of +20 °C.
Htg. curve end	• 20 ... 90 °C	This is only displayed if the controller was activated. This can be used to set the end point of the heating curve, which corresponds to a outside temperature of -10 °C.
Summer mode	• 0 ... 16 ... 30 °C	This is only displayed if the controller was activated. This can be used to set the temperature threshold at which outside temperature the heating system is to switch to summer mode.
Frost prot.	<ul style="list-style-type: none"> • Off • On 	
Frost temp. limit	• 0 ... 5 ... 10 °C	Temperature value for the system frost protection. This service function is only available if the frost protection function was activated. If the outside temperature does not exceed the frost threshold temperature, then the heating pump in the heating circuit switches on.

1) Small: < 8 radiators, medium: 8 – 15 radiators, large: > 15 radiators.

Table 21 Settings menu

7.2.4 Function check menu

Menu item	Settings/adjustment range	Comment/restriction
Activate test		
Burner	<ul style="list-style-type: none"> • Off • On 	This service function enables testing of the burner.
Ignition	<ul style="list-style-type: none"> • On • Off 	Permanent ignition. Test the ignition with permanent ignition without gas supply. ► To prevent damages to the ignition transformer, never leave this function on for longer than 2 minutes.
Fan	<ul style="list-style-type: none"> • On • Off 	Permanent fan operation. Fan operation without gas supply or ignition.
Pump	<ul style="list-style-type: none"> • On • Off 	Permanent pump run (internal or external pumps).
3-way valve	<ul style="list-style-type: none"> • Hot water • Heating 	Permanent position of the 3-way valve.
HC1 pump/DHW circ. pump	<ul style="list-style-type: none"> • On • Off 	Permanent HK1 pump run (downstream the low loss header).
Ionisat. oscill.	<ul style="list-style-type: none"> • On • Off 	Check the ionisation measurement function at the flame.
Solar pump	<ul style="list-style-type: none"> • On • Off 	Permanent pump run.

Table 22 Function check menu

7.2.5 Reset menu

Menu item	Settings/adjustment range	Comment/restriction
Default setting	Restore?	All settings of the heat source are reset to the respective default setting. The system needs to be re-commissioned following this reset.
Service display	Reset?	Only available when service is selected.
Fault history	Reset?	Reset the maintenance first. The fault history of the heat source is deleted. If currently a fault is present, it is immediately entered again.

Table 23 Reset menu

8 Inspection and maintenance

DANGER

Risk of electric shock!

- Isolate electrical components from the power supply (230 V AC) (fuse, circuit breaker) and secure against unintentional re-connection before carrying out any work. Information on safe isolation can be found in the Health and Safety Executive guidance HSG85.
- Check for zero potential before proceeding with work, using test equipment approved to GS38 to confirm that the electricity supply is disconnected.

CAUTION

Mains supplies:

- Safely isolate both the gas and electrical supply before starting any work on the appliance and observe all relevant safety precautions.

NOTICE

Personnel and equipment

- Any service work must be carried out by competent registered engineers.
- Service work must not be attempted if a calibrated CO/CO₂ analyser and manometer are not available.

WARNING

Hot surfaces!

If the appliance has been operating components may be hot.

- Ensure precautions are taken when working on the appliance.

CAUTION

Annual maintenance checks:

Annual maintenance checks have to be conducted to ensure the continued safe and reliable operation of the boiler.

- During each maintenance check, the gas valve, all gas joints and test points should be checked for leakage using an analyser/sniffer.
- If a leak is found on the gas valve then it needs replacing as a gas valve is a non-repairable component.



CAUTION

Component replacement:

- ▶ After replacement of a gas related component, where a gasket or seal has been disturbed or replaced, check for gas tightness using a gas sniffer/analyser.
- ▶ Also after re-assembly, carry out the following checks:
 - Fan pressure.
 - Flue gas analysis.

8.1 Inspection and maintenance considerations

- To ensure continued efficient operation the appliance must be checked at regular intervals.
- The frequency of servicing will depend upon the particular installation conditions and usage, however, at least an annual service is recommended.
- The extent of the service work required on the appliance is determined by the operating condition of the appliance when tested by qualified engineers.
- After each service, the service interval record sheet at the rear of this manual, must be completed.

See the following instructions for detail of some of the service requirements:

- ▶ Check all joints and connections in the system and remake any that show signs of leakage. Refill and re-pressurise if applicable as described in the commissioning section.
- ▶ When it is frequently necessary to add water to maintain pressure in the installation, even though no leaks have been discovered, perform an expansion vessel check.
- ▶ Check that the condensate system is not obstructed, clean and refill the condensate siphon.
- ▶ If the appliance is in a compartment or cupboard check that the specified clearances around the appliance is clear.
- ▶ Check that the flue system is unobstructed and undamaged, clean/replace as necessary.
 - If fitted ensure the flue terminal guard is also unobstructed and undamaged.
- ▶ Operate the appliance and take note of any irregularities.
 - Refer to the fault finding pages for rectification procedure.

8.2 Resources for inspection and maintenance

- The following measuring devices are required:
 - Electronic flue gas analyser for CO₂, O₂, CO and flue gas temperature
 - Pressure gauge 0 - 30 mbar (minimum resolution 0.1 mbar)
- ▶ Use heat conducting paste 8 719 918 658 0.
- ▶ Use approved greases.

8.3 Inspection and maintenance steps

→ chapter 12.9

Maximum system pressure

- ▶ 2.5 bar must not be exceeded when the heating system water is at maximum temperature. If this pressure is exceeded then an additional expansion vessel must be fitted into the system return as close as possible to the appliance.
- ▶ If the system does not retain the pressure, the pressure relief valve (PRV) and the heating system should be checked for leaks.

8.4 Component access

Removing bottom panel

1. Push in the clip securing the bottom panel.
2. Pull bottom panel sideways to release from service position and remove.

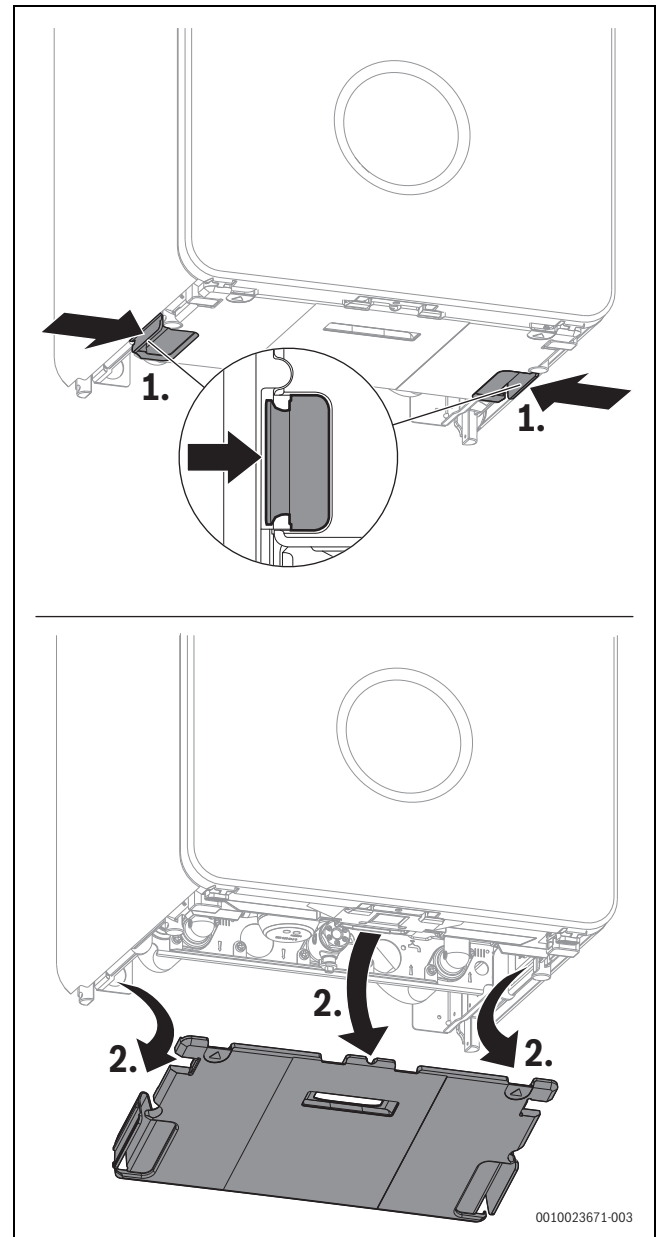

Fig. 77 Removing bottom panel

Removing front cover

1. Remove screw from bottom of front panel.
2. Push in the green clips securing both sides the outer case.
3. Pull bottom of front cover forwards and upwards to release the clip on top of the boiler and remove outer case.

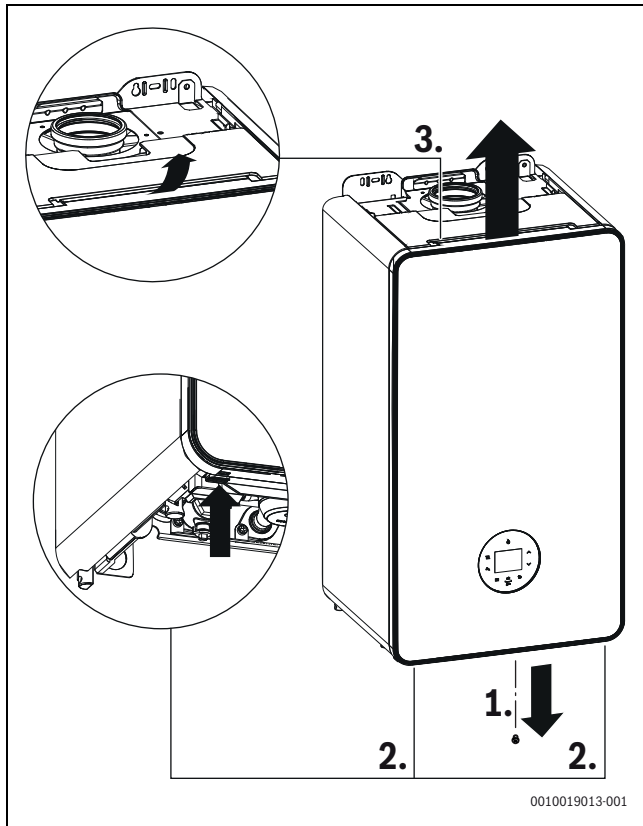

Fig. 78 Removing outer case

8.5 Fan pressure test

NOTICE

Fan pressure test

- ▶ The appliance must be running at maximum output in chimney sweep mode for the fan pressure test (→ chapter 6.4).

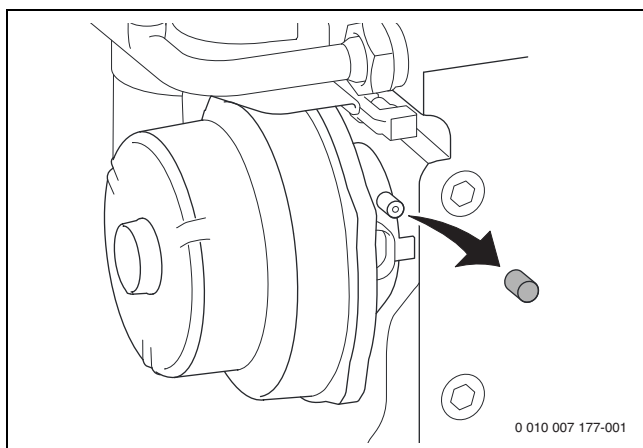

Fig. 79 Fan pressure test point



This test is to determine if the heat exchanger requires cleaning or additional actions.



Fan pressure test reading.

- ▶ The pressure reading will be in negative values.

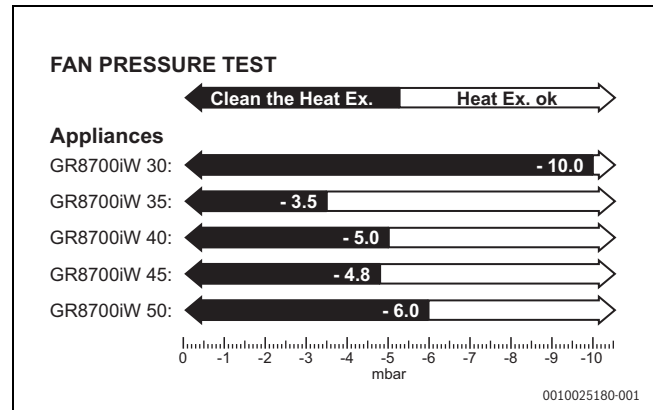

Fig. 80 Fan pressure test values

Appliance fan pressure test values

Natural Gas appliances

Appliance	×	←	↓ Value [P]
GR8700iW 30	0 mbar	to	-10,0 mbar
GR8700iW 35	0 mbar	to	-3,5 mbar
GR8700iW 40	0 mbar	to	-5,0 mbar
GR8700iW 45	0 mbar	to	-4,8 mbar
GR8700iW 50	0 mbar	to	-6,0 mbar

Table 24 Natural Gas appliances

[×] Cleaning required

[✓] No cleaning required

If the manometer reading is higher then the appliance output value [P] mbar.

- ▶ The heat exchanger/exhaust path/siphon does not require attention.

If the manometer reading shows the heat exchanger requires cleaning, then carry out the following checks.

- ▶ Check that the siphon is not restricted or blocked.
- ▶ Check the exhaust paths for restrictions.
- ▶ Clean the heat exchanger with a suitable cleaning tool, refer to cleaning section.
- ▶ Re-check the fan pressure readings.
If the boiler, after completing the above checks, fails the fan pressure test then contact Worcester, Bosch Group for advice.
- ▶ Replace test point cover after completing pressure check.

8.6 Check working gas inlet pressure

NOTICE

Gas inlet pressure

- ▶ Do not continue with the other checks if the correct gas inlet pressure can not be achieved at maximum output.
- ▶ Check the gas supply working pressures in the system conform to the readings shown in the table shown in chapter 6.6 "Checking gas inlet pressure".

8.7 Flue gas analysis

NOTICE

Combustion testing

- ▶ Combustion testing must be carried out by a competent person. Testing must not be attempted unless the person carrying out the combustion check is equipped with a calibrated flue gas analyser conforming to BS 7967 and is competent in its use.



Flue gas analysis

- ▶ Ensure that the gas inlet pressure has been checked and is satisfactory.
 - ▶ Refit the test point plugs after the test has been completed.
-
- ▶ Set the appliance to maximum and minimum output in chimney sweep mode for the flue gas analysis checks (→ chapter 6.4).
 - ▶ Check that the readings conform to those given in the following tables. In addition to CO and CO/CO₂ ratio checks also check the maximum and minimum CO₂ percentage reading.

Gas type	Maximum rated output			Minimum rated output		
	CO ₂	O ₂	CO	CO ₂	O ₂	CO
Natural gas	9.5 % ± 0.4	4.0 %	<250ppm	8.6 % ± 0.4	5.5 %	<75ppm
Liquid propane (LPG)	10.8 % ± 0.4	4.6 %	<250ppm	10.2 % ± 0.4	5.5 %	<75ppm

Table 25 CO₂ and O₂ contents

If the CO₂ is out of tolerance then please check:

- ▶ The gas inlet pressure.
- ▶ The gas rate.
- ▶ The fan test pressure.
- ▶ The flue and air intake, plus any possible blockages in the condensate disposal.
- ▶ The condition of burner.
- ▶ For leaks or obstructions in the exhaust paths.
- ▶ CO₂ is correctly adjusted.

The gas valve and venturi are factory set and should not need to be adjusted, if found to be out of tolerance and when all other possible causes have been checked, please contact the Worcester Bosch Group Helpline 0330 123 3366.

8.8 Checking the flue integrity

NOTICE

- ▶ Check flue joints are secure, the terminal and the terminal guard, if fitted are clear and undamaged.
- ▶ Combustion testing must be carried out to BS 7967 by a competent person. Testing must not be attempted unless the person carrying out the combustion check is equipped with a calibrated Combustion Analyser conforming to BS EN 50379 and is competent in its use.



Flue gas analysis

- ▶ Ensure that the gas inlet pressure has been checked and is satisfactory.
- ▶ Refit the test point plugs after the test has been completed.

- ▶ Refer to chapter 6.10 "Checking flue integrity" and check that the readings conform to those given, confirming flue system and combustion circuit are ok.

8.9 Cleaning the siphon and heat exchanger



WARNING

Gaskets and seals - gas related components

- ▶ Burner/electrode assembly gasket must be replaced if disturbed.
- ▶ Other gaskets/seals must be checked and replaced where necessary.
- ▶ Do not attempt the cleaning procedure unless new gaskets and seals are available.



There is an optional tool available to assist in cleaning the heat exchanger, part number 7 719 001 996.

8.9.1 Checking the burner

1. Remove the combustion cover (→ Fig. 68).
2. Unscrew the screws on the burner cover.
3. Remove the burner cover.

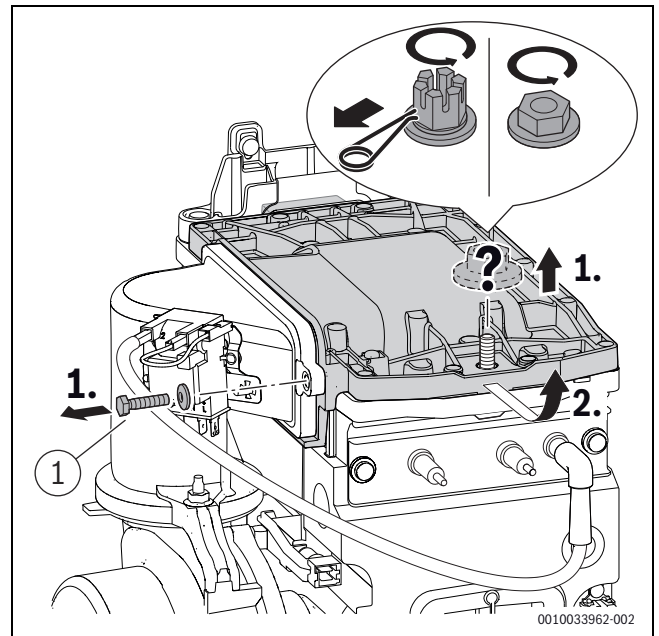

Fig. 81 Removing the burner cover

- ▶ Remove the burner and clean its components.

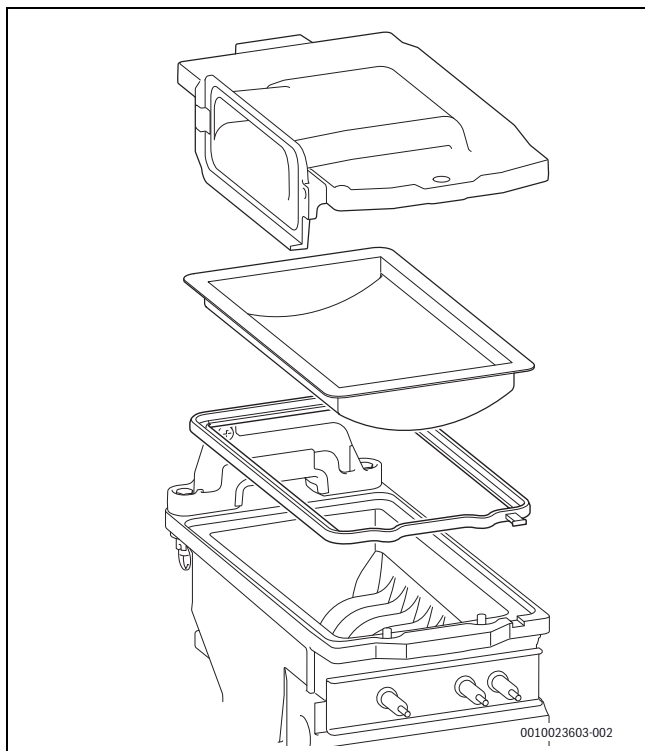

Fig. 82 Burner

- ▶ Reinstall the burner in reverse order, including a new gasket.



The GR8700iW 45 and 50 appliances have a different gasket.

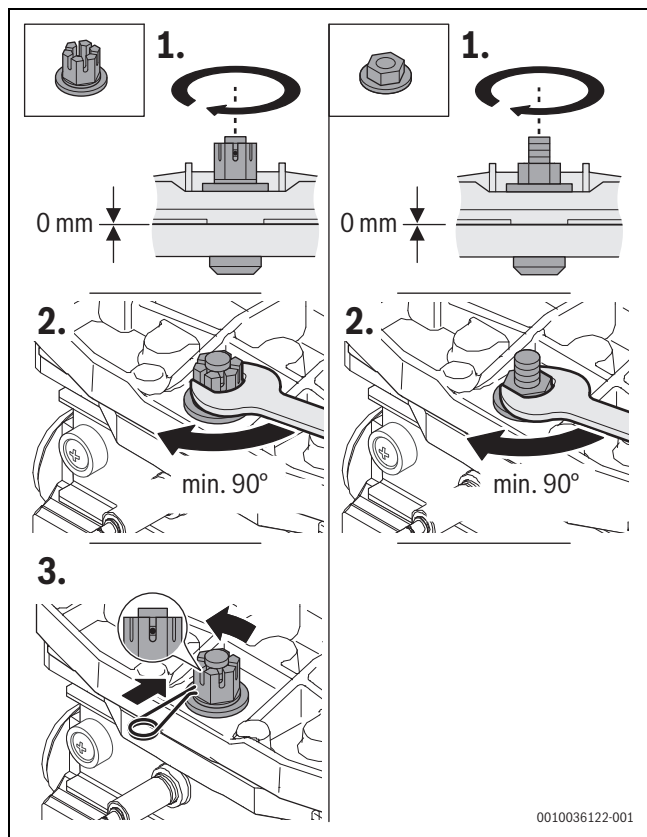

Fig. 83

- ▶ Install the burner cover.

- ▶ Tighten the nut until the gap in front of the bolt is completely closed and the nut stops turning when the metal surfaces just touch.
- ▶ Tighten the nut an additional 90°
- ▶ Check the gas/air ratio.

8.9.2 Checking the non-return valve in the air-gas manifold

1. Unplug the transformer.
2. Unscrew the screws at the air-gas manifold.
3. Remove the air-gas manifold.

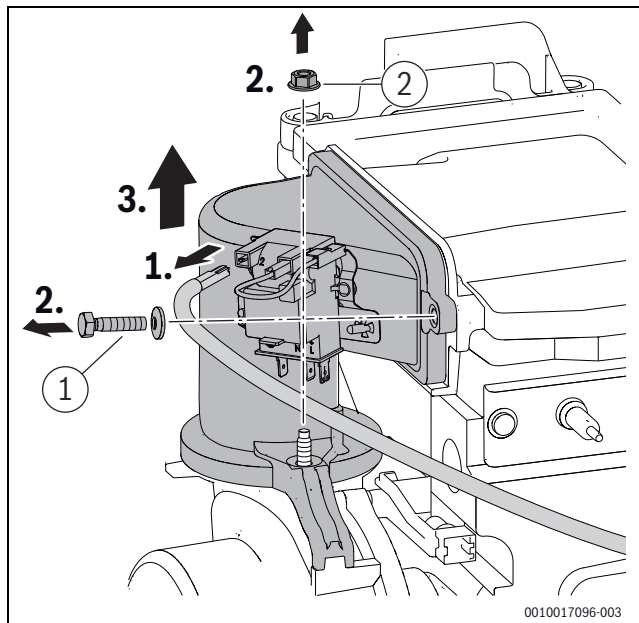

Fig. 84 Removing the air-gas manifold

1. Remove the non-return valve.
2. Check the non-return valve for contamination and cracks.

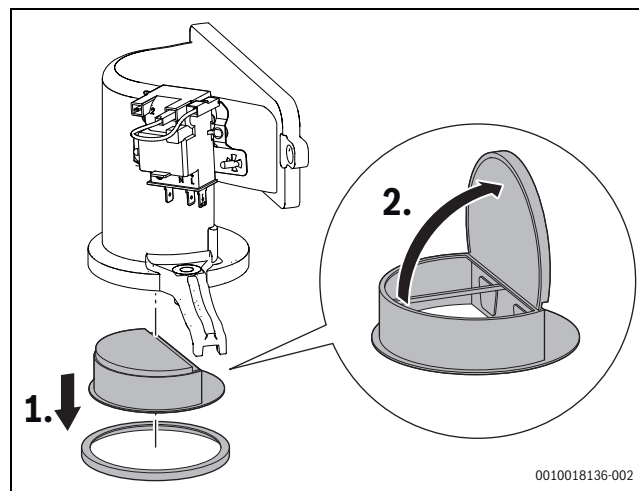

Fig. 85 Non-return valve in the air-gas manifold

- ▶ Install the non-return valve.
- ▶ Install the air-gas manifold.

8.9.3 Fan removal

1. Undo connection of venturi.
2. Remove venturi and move pipe to the far right.

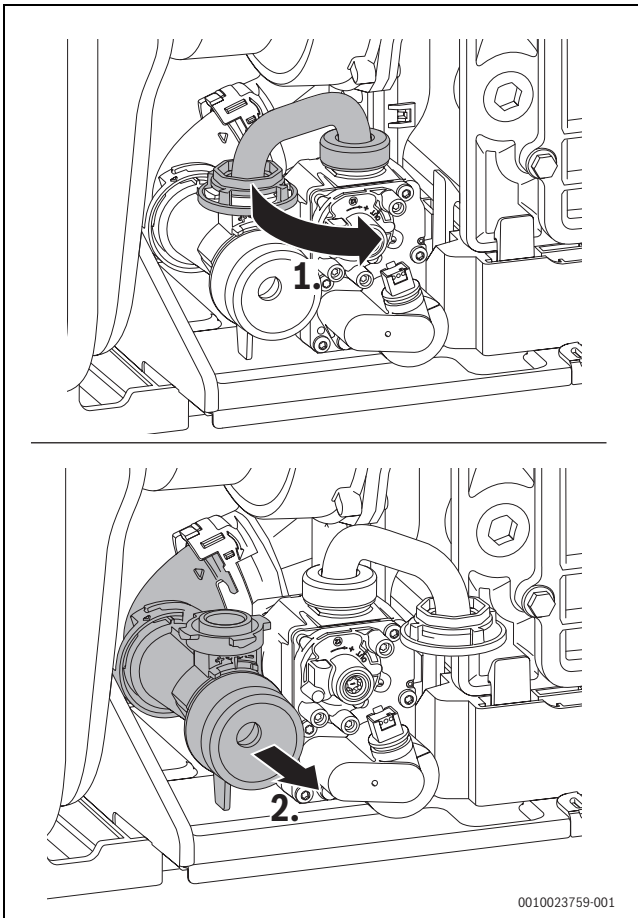

Fig. 86 Venturi removal

3. Remove expansion foam (pull towards you).
4. Undo fan connection and remove screw and seal.
5. Remove fan.

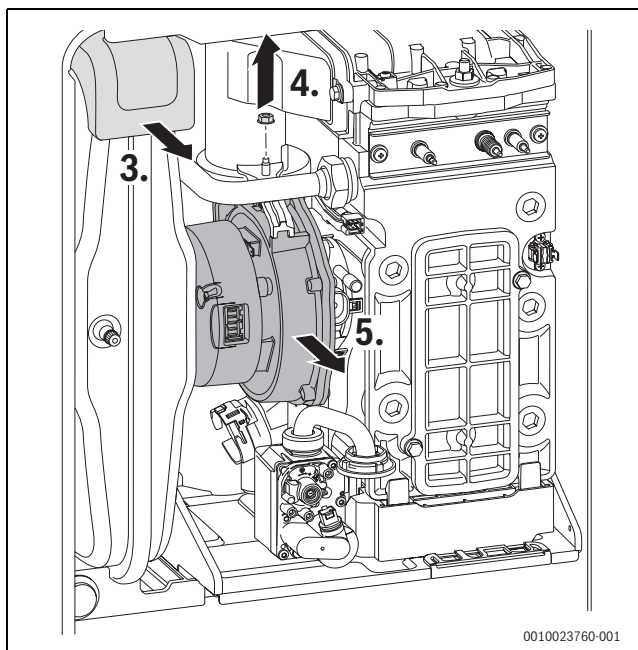

Fig. 87 Fan removal

8.9.4 Cleaning the heat exchanger

Access to the heat exchanger

The following items will have to be removed to gain access to the heat exchanger for cleaning:

- ▶ Remove the combustion casing.
- ▶ Lower the control panel into the service position.
- ▶ Disconnect electrical wires to the fan, ignition transformer, spark electrodes, flue overheat thermostat, main heat exchanger temperature sensor and flow pipe temperature sensor.
- ▶ Flue way
- ▶ Fan assembly
- ▶ Ignition transformer
- ▶ Spark electrode assembly
- ▶ Burner housing, burner and gasket

Cleaning the heat exchanger

- ▶ Remove the siphon and place a suitable container under the outlet to catch the water and debris.
- ▶ Protect the controller from water ingress.



The heat exchanger does not have to be removed in order to clean. The heat exchanger is shown removed from the appliance to illustrate cleaning more clearly.

- ▶ Remove the cleaning access cover [1] and seal [2].

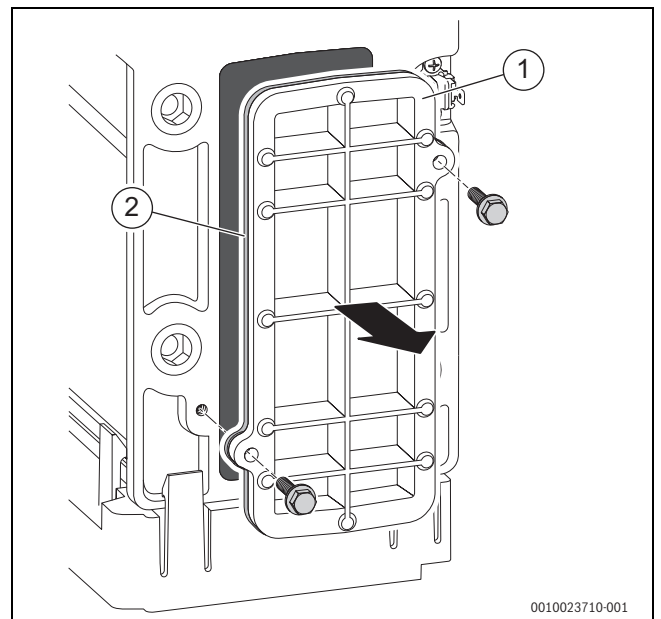

Fig. 88 Access cover removal

- ▶ Using the cleaning blade, working from the bottom to the top, to loosen any deposits in the heat exchanger.

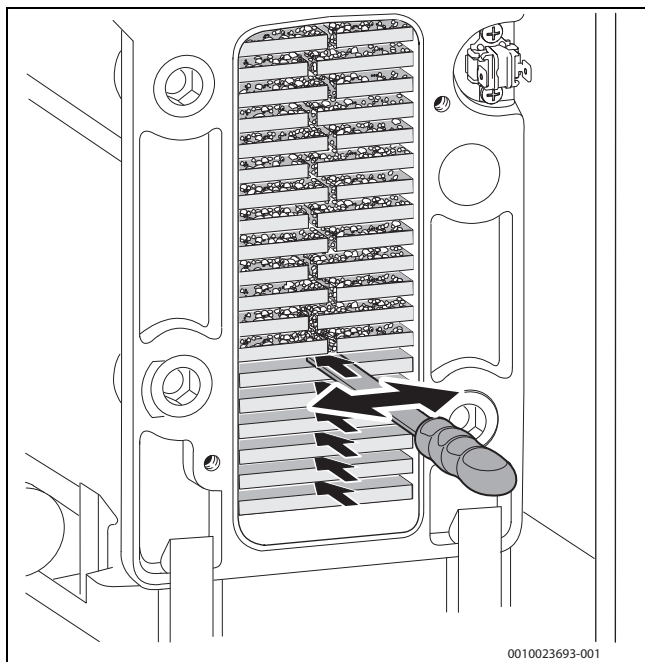

Fig. 89 Cleaning blade

- ▶ Using the brush, clean the heat exchanger from top to bottom.

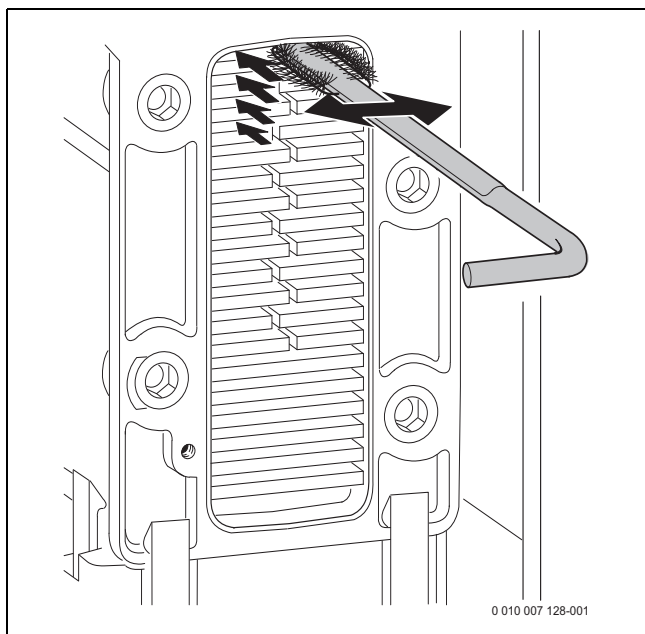

Fig. 90 Cleaning brush

- ▶ Use the handle of the brush to remove debris from the condensate tray.



It is possible to rinse any remaining debris from the heat exchanger either through the access point or alternatively through the top of the heat exchanger when the burner is removed.

- ▶ Pour water into the heat exchanger to rinse the debris through to the suitable container below the outlet to the siphon.

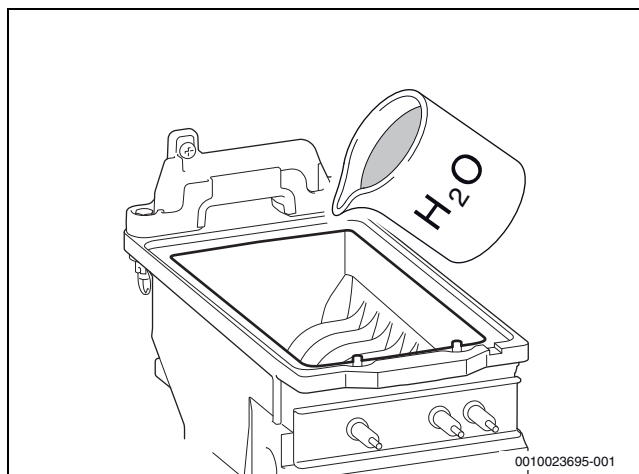

Fig. 91 Pour water into the heat exchanger

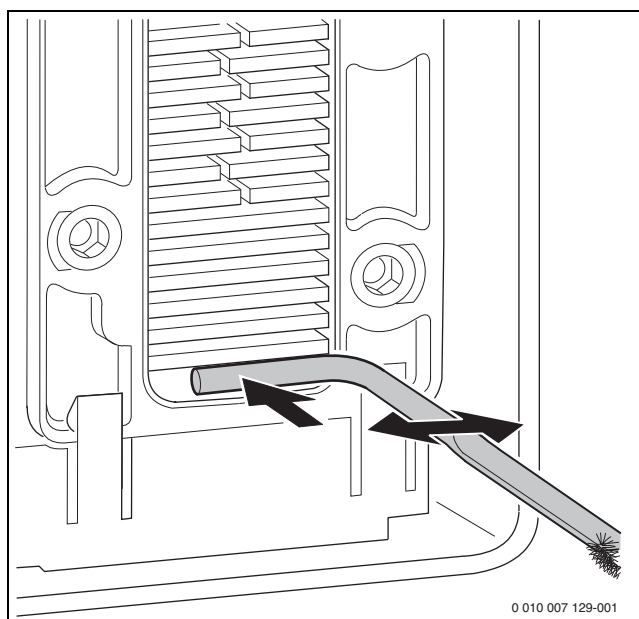

Fig. 92 Cleaning debris

- ▶ Refit the cleaning access cover assembly in reverse order the new seal [2], and the access cover [1].
- ▶ Fully tighten the bolts.

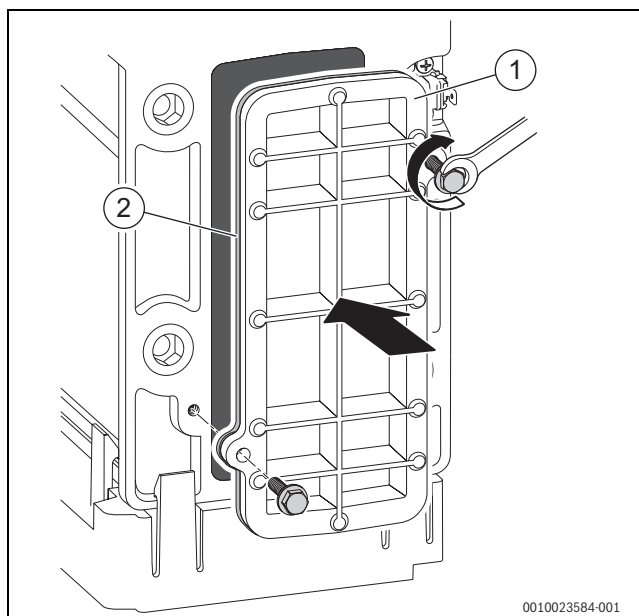

Fig. 93 Re-fitting the access cover

- ▶ Ensure that the convex side of the burner faces down into the heat exchanger when re-fitting the burner.
- ▶ Ensure seal is replaced with new seal and is correctly fitted.
- ▶ Check the siphon unit is clean before refitting to appliance.



On completion of the heat exchanger cleaning and reassembly, perform the fan pressure test.

8.9.5 Checking electrodes

- ▶ Remove the electrode set with gasket.
- ▶ Check electrodes for contamination.
- ▶ Clean or replace electrodes if required.
- ▶ Install electrode set with new gaskets.
- ▶ Ensure the screws are fully tightened.

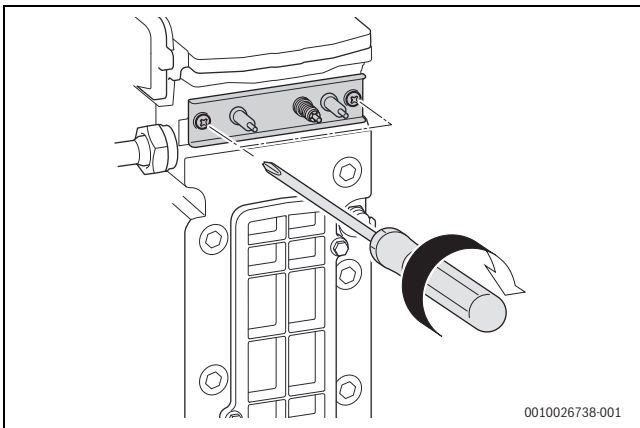

Fig. 94 Installing electrode set

- ▶ Check integrity of seal of electrode set. Using a mirror to check for misting.

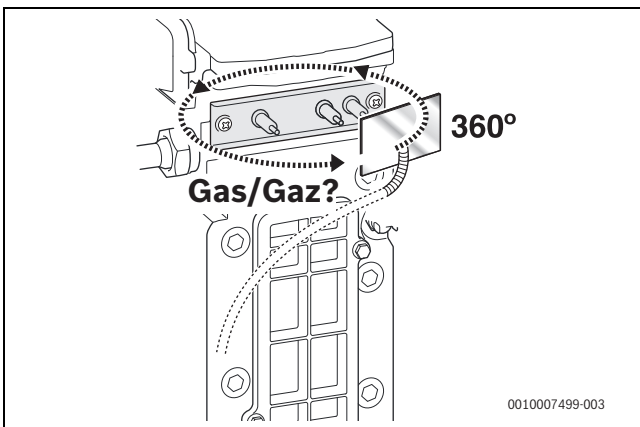

Fig. 95 Checking for leaks with an inspection mirror. Observe for misting.

8.9.6 Cleaning the siphon

Cleaning the condensate trap

! WARNING

Danger to life due to poisoning!

If the condensate trap is not filled, poisonous flue gas can escape.

- ▶ Only turn off the siphon filling program during maintenance, and turn it back on at the end of maintenance.
- ▶ Make sure that the condensate drains off properly.



Damages resulting from an insufficiently cleaned condensate trap are excluded from the warranty.

- ▶ Clean the condensate trap regularly.

1. Whilst supporting the condensate trap, firmly press the unlock mechanism, until an audible click is heard.
2. Pull the condensate trap forwards and tilt to the left for draining.
3. Once empty pull the hose from the condensate trap.

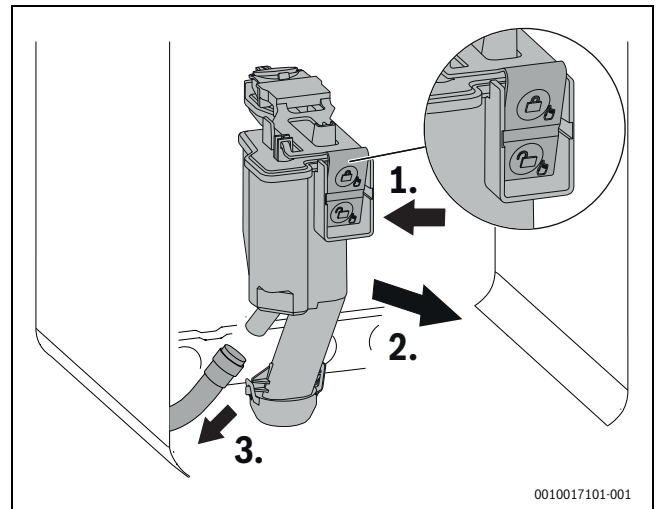

Fig. 96 Removing the condensate trap

- ▶ Remove the condensate trap.
- ▶ Clean the condensate trap, and check that the aperture towards the heat exchanger is clear.
- ▶ Remove the gasket on the top of the condensate trap.
- ▶ Check the gasket for cracks, deformation or breakage and replace if required.
- ▶ Align the new gasket correctly with the condensate trap.

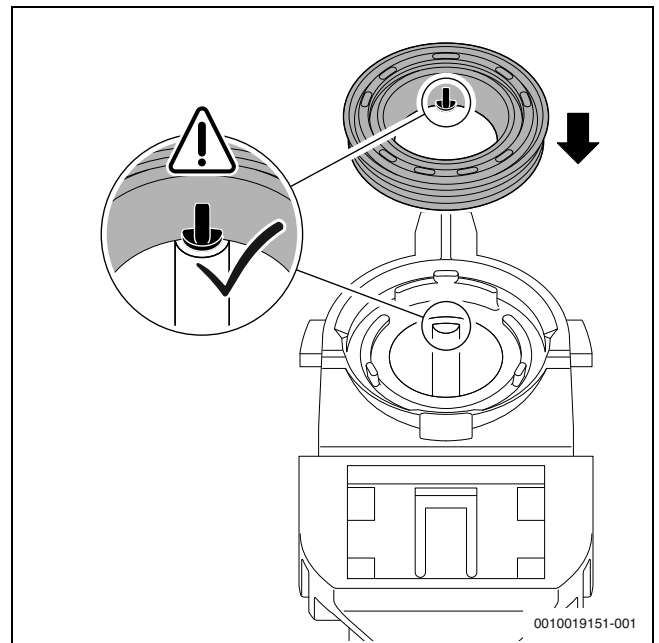

Fig. 97 Aligning the new gasket with the condensate trap

- ▶ Press on the gasket in the required order.
When the gasket is correctly inserted, the pin is visible in the recess and is flush with the top edge of the gasket.

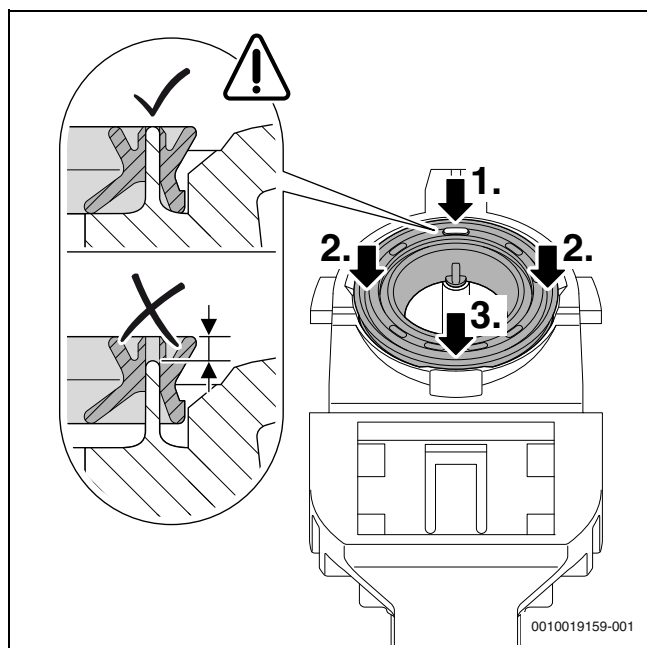

Fig. 98 Pressing on the gasket

- ▶ Check the condensate hose and clean if required.
- ▶ Fill the condensate trap with approx. 250 ml water.
- ▶ Replace the condensate trap. An audible click will indicate locking. Ensure condensate trap is secured correctly.

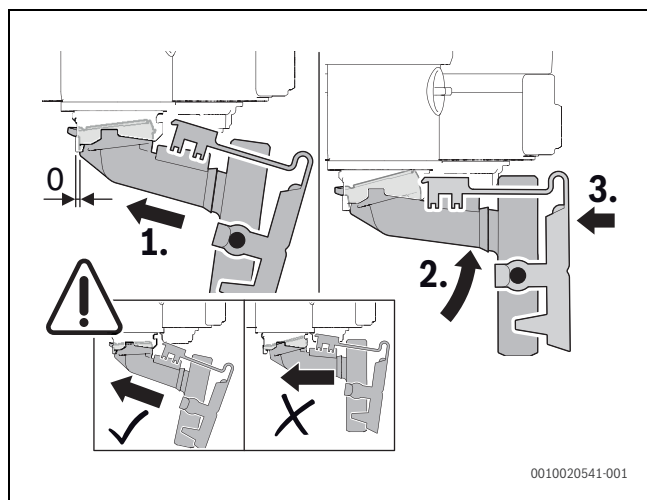

Fig. 99

8.10 Setting the air/gas ratio

NOTICE

Setting the air/gas ratio

- ▶ The gas valve and venturi are factory set and should not need to be adjusted if found to be out of tolerance and when all other possible causes have been checked, please contact the Worcester Bosch Group Helpline 0330 123 3366.

NOTICE

Combustion testing

- ▶ The setting of the air/gas ratio **must** be carried out by a competent registered gas engineer, such as a Gas Safe registered engineer or British Gas engineer.
- ▶ Setting of the air/gas ratio **must not** be attempted unless the person carrying out the test is equipped with a flue gas analyser conforming to BS7927 and is competent in its use.



All CO/CO₂ readings must be taken with the combustion chamber cover ON. Adjustments can only be made with the cover off.



CO₂ should be measured 10 minutes after firing the appliance.

8.10.1 Checking and, if required, adjusting the gas/air ratio

- ▶ Switch off the appliance.
- ▶ Remove the front cover.
- ▶ Remove the combustion cover.

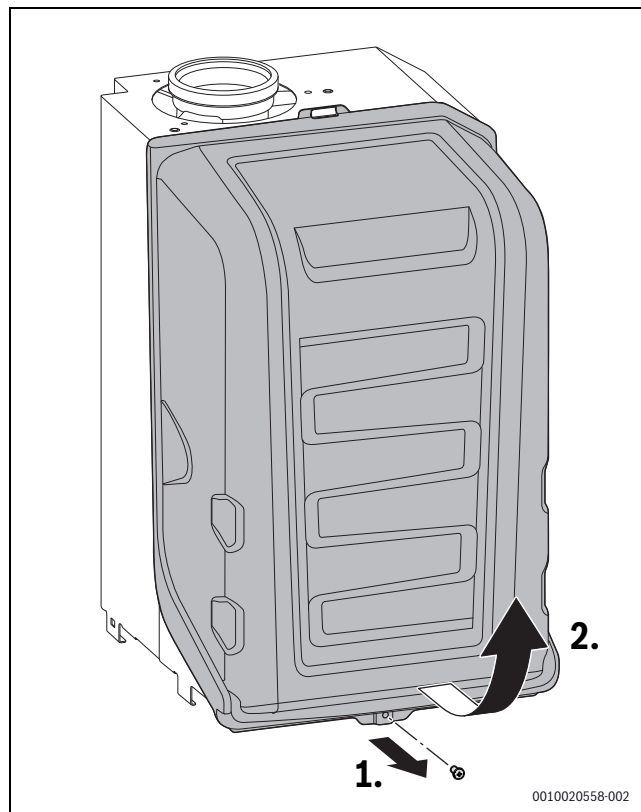

Fig. 100 Removing the combustion cover

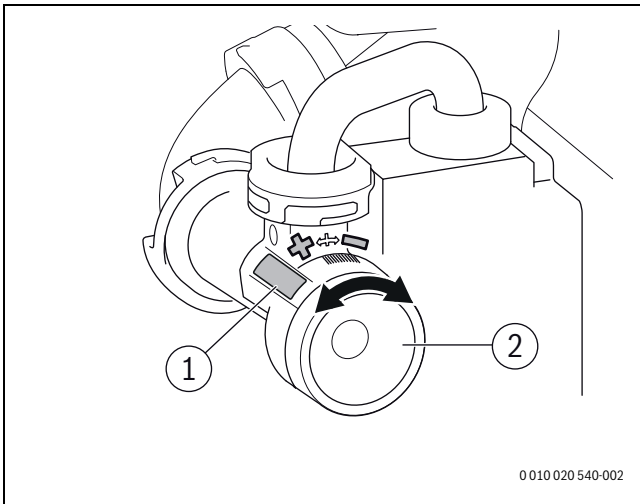

Fig. 101 Setting the adjustable venturi

- [1] Security Seal
- [2] Adjustable venturi

- ▶ Switch on the appliance.
- ▶ Remove the plug from the flue gas test port.
- ▶ Push the flue gas probe centrally into the flue gas test port.
- ▶ Seal the test point.

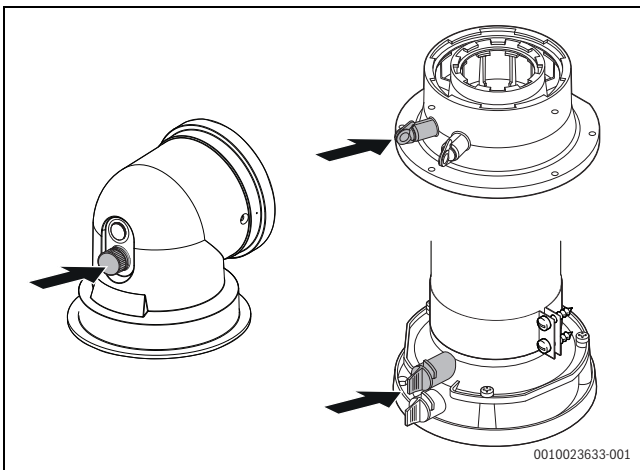

Fig. 102 Flue gas test port

- ▶ To ensure heat transfer: open the radiator valves.
- ▶ Set the chimney sweep mode and start up the appliance at maximum rated output.
- ▶ Measure the CO₂ or O₂ content.
- ▶ Check the CO₂ or O₂ content at maximum rated output according to Tab. 26 and adjust if required.



Security Seal [1] (→ Fig. 101) must be removed before adjusting the Max CO₂ setting. Once adjustment has been made the seal must be replaced with part number 8737708988.

- ▶ To increase the CO₂ content, remove seal [1] and turn the adjustable venturi to the left.
- ▶ To reduce the CO₂ content, remove seal [1] and turn the adjustable venturi to the right.

Gas type	Maximum rated output			Minimum rated output		
	CO ₂	O ₂	CO	CO ₂	O ₂	CO
Natural gas	9.5% ± 0.4	4.0%	<250ppm	8.6% ± 0.4	5.5%	<75ppm
Liquid propane (LPG)	10.8% ± 0.4	4.6%	<250ppm	10.2% ± 0.4	5.5%	<75ppm

Table 26 CO₂ and O₂ contents

- ▶ Measure the CO content.
The CO content must be < 250ppm.
- ▶ Set the minimum rated output.
- ▶ Measure the CO₂ or O₂ content.
- ▶ Remove the seal from the adjusting screw of the air/gas ratio control valve (only air/gas ratio control valve is shown in the below Fig. 103) and set the CO₂ or O₂ content for minimum rated output.

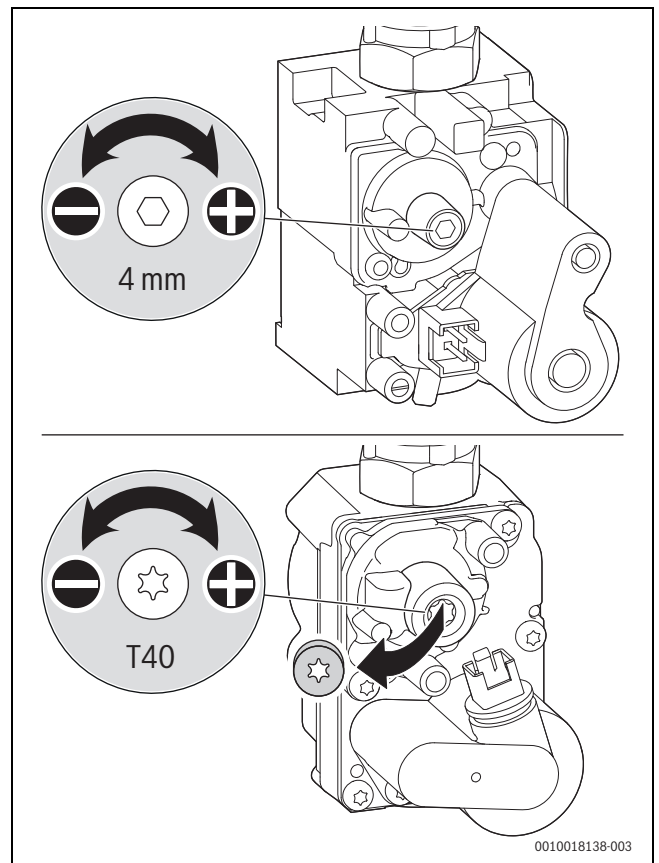

Fig. 103 Setting the CO₂ or O₂ content (above: SIT valve, below: Honeywell valve)

- ▶ Re-check settings at maximum and minimum rated output and re-adjust if required.
- ▶ Seal the air/gas ratio control valve.
- ▶ Seal the adjustable venturi.
- ▶ Exit the chimney sweep mode.
- ▶ Enter the CO₂ contents in the servicing record (→ chapter 12.8, page 92).
- ▶ Remove the flue gas probe from the flue gas test port and refit the plug.

9 Replacement parts

WARNING

Mains supplies - Isolate the appliance

- ▶ Turn off the gas supply and isolate the mains electrical supply before starting any work and observe all relevant safety precautions.
- ▶ Drain the appliance/system where necessary and protect any electrical equipment from water ingress during component replacement.

WARNING

Component replacement:

- ▶ After replacement of a gas carrying component, where a gasket or seal has been disturbed or replaced, check for gas tightness using a gas sniffer/leak detection fluid.
- ▶ On re-assembly check all affected seals for cracks, hardness and deterioration.
 - If damaged or in any doubt the seal must be replaced.
- ▶ Also after re-assembly, carry out the following checks:
 - Fan pressure.
 - Flue gas analysis.



Only use Worcester, Bosch Group original spare parts with this appliance. Non Worcester, Bosch Group original spare parts will invalidate the guarantee (if applicable) and any warranty.

- ▶ A comprehensive list of appliance spares can be found on the website www.worcester-bosch.co.uk/spares

9.1 Draining the appliance

NOTICE

Risk of water damage to appliance or property!

Damage from disconnecting water pathways which may have retained some water.

- ▶ Take care after draining the appliance to protect equipment/property from residual water content within components.

Many of the tasks in this section require that the appliance be isolated and drained. This will be indicated in the manual if required.

- ▶ The boiler drain is already connected to the condensate trap for ease of draining.

-or-

- ▶ Connect a suitable hose firmly to the drain point and run the hose outside to a suitable point or container.
- ▶ Turn the drain valve a ¼ turn anti-clockwise to open the drain. Turn the valve firmly clockwise to close.

9.2 Overheat thermostat removal

- ▶ Remove two electrical connectors from thermostat.
- ▶ Unscrew [1] the sensor [2].

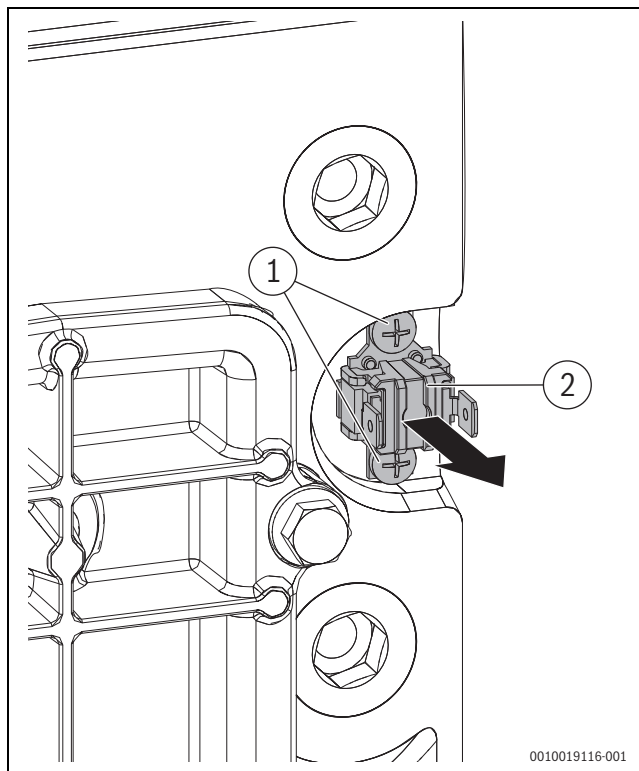

Fig. 104 Removing overheat thermostat

9.3 Pressure sensor removal

- ▶ Open the cover (→ Fig. 68).
- ▶ Remove the condensate trap (→ Fig. 96).

1. Pull the spring forward.
2. Remove the pressure sensor.

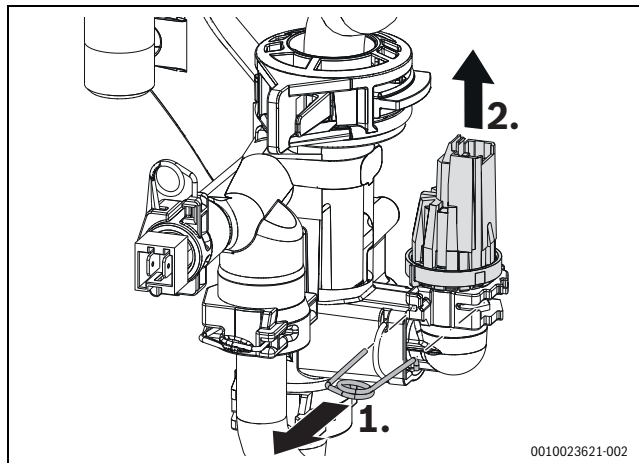

Fig. 105 Removing pressure sensor

9.4 Pressure relief valve removal

- ▶ Open the cover (→ Fig. 68).
- ▶ Remove the condensate trap (→ Fig. 96).
- 1. Pull the spring up.
- 2. Press the PRV Pipe forward lightly.
- 3. Unscrew the knurled nut.
- 4. Remove the lower pipe from the Pressure relief valve.

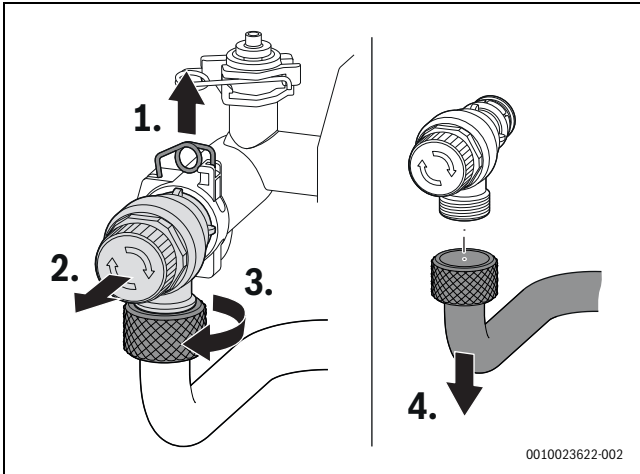

Fig. 106 Removing pressure relief valve

9.5 Replacing the gas valve

- ▶ Close the gas isolator.
- 1. Unscrew the bayonet connection.
- 2. Unscrew the union nut.
- 3. Remove the gas pipe.

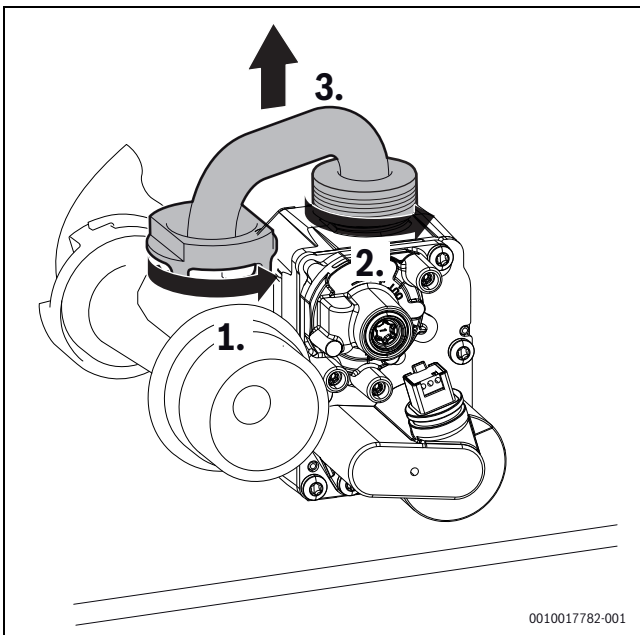

Fig. 107 Removing the gas pipe

- 1. Unplug the plug.
- 2. Unscrew the union nut.

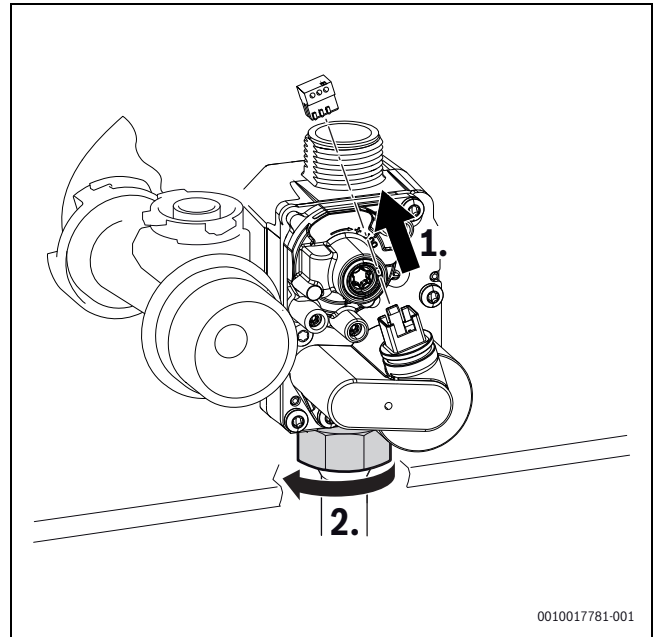

Fig. 108 Unplugging the plug and unscrewing the union nut

- 1. Remove the 2 screws.
- 2. Remove the air/gas ratio control valve.

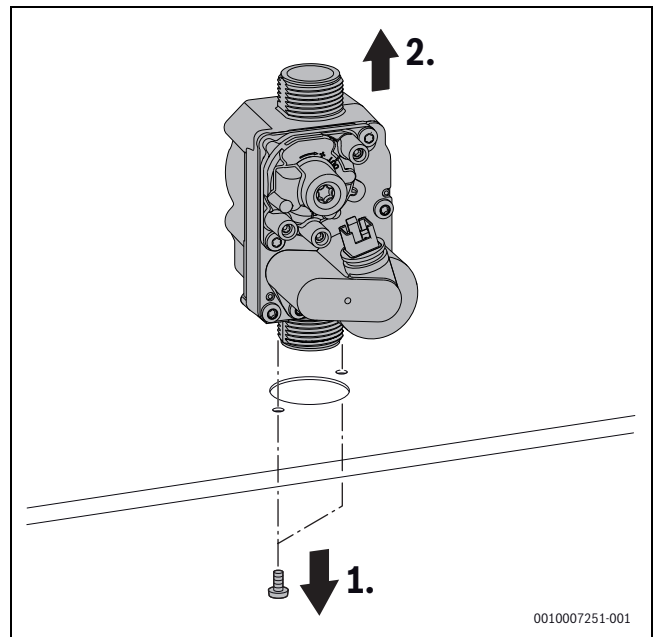

Fig. 109 Removing the gas control valve

- ▶ Install the air/gas ratio control valve in reverse order, and check the gas/air ratio.

9.6 Checking the strainer in the cold water pipe and the flow turbine

1. Remove the clip.
2. Loosen the cold water pipe.
3. Pull the strainer out of the cold water pipe and check for contamination.

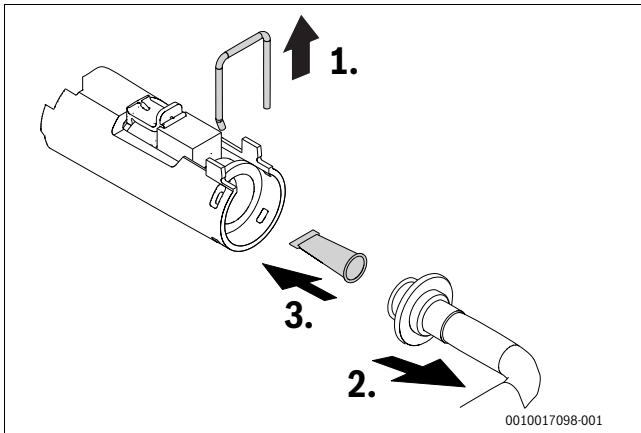

Fig. 110 Removing the strainer from the cold water pipe

1. Pull out the flow turbine.

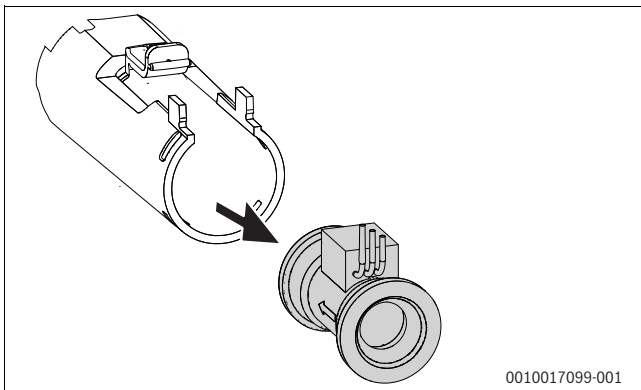

Fig. 111 Removing the flow turbine at the cold water pipe

- ▶ Select in the Service menu > Info > DHW flow rate.
- ▶ Blow in the flow direction of the turbine.
- ▶ If nothing appears on the display, replace the turbine.

9.7 Checking/replacing the motor of the 3-way valve

- ▶ Check the motor in the Menu > Function check > Activate test > 3-way valve.
 - ▶ Check/replace the motor of the 3-way valve in the Service menu > Special function > 3-WV mid. pos. > Yes.
1. Pull out the motor.
 2. Press the cable retaining clip.
 3. Unplug the plug.

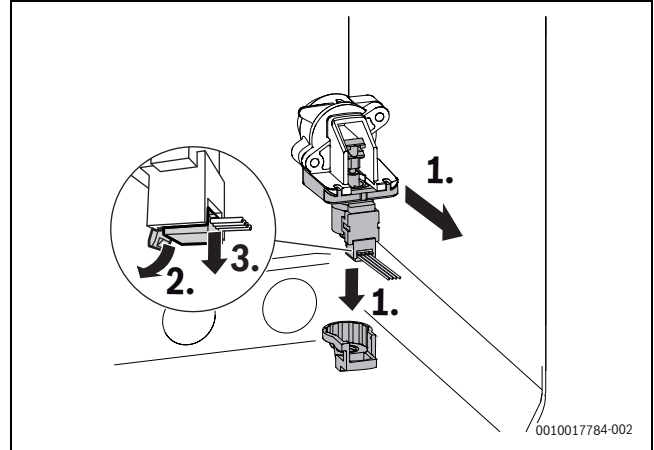

Fig. 112 Removing the motor of the 3-way valve

9.8 Replacing the 3-way valve

- ▶ Remove the screws.
- ▶ Pull out the 3-way valve.
- ▶ Press the cable retaining clip.
- ▶ Unplug the plug.

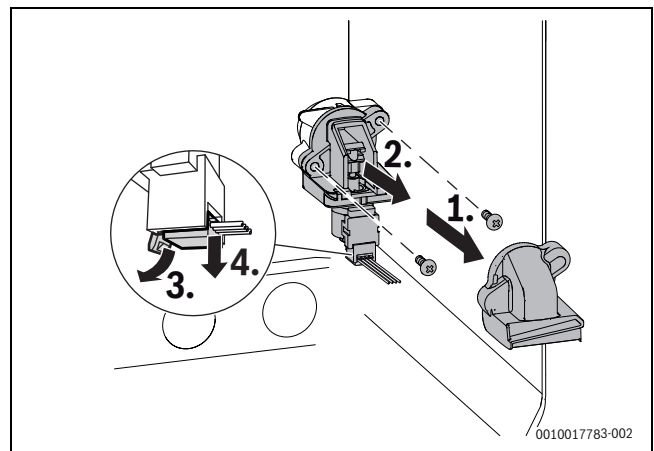

Fig. 113 Removing the 3-way valve

9.9 Replacing the plate heat exchanger

- ▶ Check the strainer in the cold water pipe for contamination (→ Chapter 9.6, page 72).

-or-

- ▶ Remove the plate heat exchanger and replace.
 1. Remove the screws.
 2. Remove the plate heat exchanger.

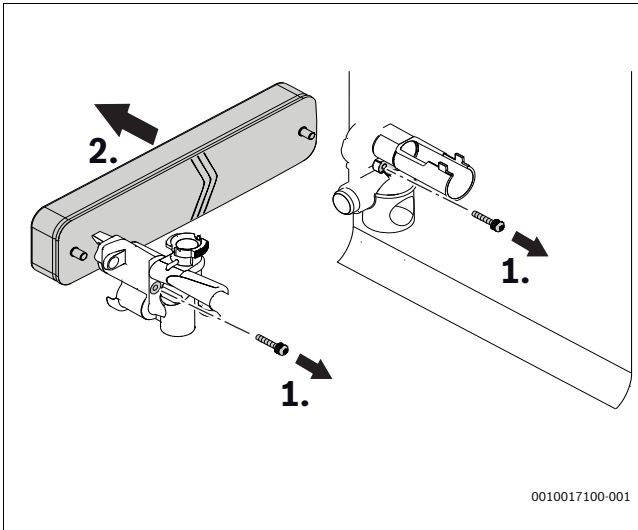

Fig. 114 Removing the plate heat exchanger

- ▶ Install the new plate heat exchanger in reverse order.
- ▶ Make sure that the label "bottom" is facing downwards.

9.10 Following inspection/maintenance

- ▶ Re-tighten all the threaded connections that have been released.
- ▶ Restart the appliance.
- ▶ Check tightness of all joints.
- ▶ Check the gas/air ratio.
- ▶ Fit the combustion casing, side-, top panels and front cover.

10 Fault finding and diagnosis



This fault finding information is for guidance only. Worcester cannot be held responsible for costs incurred by persons not deemed to be competent.



This fault finding system assumes that the appliance has been operating normally until the time of failure (i.e. not a first time installation error).

Basic checks

- Ensure that there is 230V power supply and the polarity is correct to the appliance.
- Ensure that the appliance settings and functionality is correct.
- Ensure the CH/DHW programmer/timer is functioning.
- Ensure the room thermostat is functioning.
- Ensure the cylinder thermostat (if fitted) is functioning.
- Ensure the cold water mains is turned on.
- Ensure the primary system has adequate pressure/system content for the system type.
- Ensure there is gas to the appliance.
 - Are other gas appliances working, gas cooker/hob for example?
 - Has the credit run out on the gas pre-payment meter?

NOTICE

On completion of the Service/Fault-Finding task which has required the breaking and remaking of electrical connections, check:

- ▶ Earth continuity,
- ▶ Short circuit check,
- ▶ Polarity,
- ▶ Resistance to earth.

10.1 Operating and fault displays

10.1.1 General information

- **Fault code:** indicates which fault is present.
- **Fault category:** indicates what kind of fault is present and its effects.

Fault category O (operating code)

Operating codes indicate the operating conditions in normal operation.

Fault category B (blocking faults)

Blocking faults result in the heating system being shut down temporarily. The heating system restarts automatically as soon as the blocking fault is removed.

Fault category V (locking faults)

Locking faults result in the heating system being shut down, and the system can only be restarted after a reset.

- ▶ Press the ▲ and ▼ keys, until **Reset** is displayed. The appliance resumes operation.

If a fault persists:

- ▶ Rectify the fault according to 10.1.2 Fault code table

Fault category W (maintenance codes)

10.1.2 Fault code table

Fault code	Fault category	Fault text on the display	Remedy
200	O	Boiler in heating mode	Operating message, is not a fault.
201	O	Boiler in hot water mode	Operating message, is not a fault.
202	O	Boiler in anti-cycle mode	Operating message, is not a fault.
203	O	Boiler in standby, no heat energy demand	Operating message, is not a fault.
204	O	Current prim. water temp. higher than set val.	The actual boiler water temperature is higher than the target boiler water temperature. The boiler is switched off.
208	O	Chimney sweep demand	Operating message, is not a fault.
214	V	Fan shut down during safety time	<ol style="list-style-type: none"> 1. Reset the appliance. 2. Create a heat demand does the boiler fire up. 3. Check the voltage to the fan and the continuity of the fan harness. 4. Check the power modulation on the fan. 5. PCB is may be defective.
224	V	Maximal flue gas thermostat or heat exchanger maximal thermostat has activated	<ol style="list-style-type: none"> 1. Check if lead disconnected from the safety temperature limiter. 2. Check the high limit of the safety temperature limiter and the harness for continuity. 3. Check the flow temperature to confirm actual temperature (may tripped out at lower temperature, leading to safety temperature limiter fault) 4. Check the system pressure and top up as required. 5. Check if air trapped in the system and in the boiler. 6. Pump seized/not running: check the pump for failure or if she blocked. 7. Check if blockage/restriction within boiler/pipe work restricting the flow.
227	V	No flame signal after ignition	<p>Tip: Check the ceramic insulator is not damaged, this can cause the spark to earth, twist and pull the ceramic insulator to ensure it is not broken.</p> <ol style="list-style-type: none"> 1. Check the gas supply to property and the inlet on the gas valve. 2. Check the low pressure when the gas valve opens. 3. Gas valve failing to open: check for voltage to the valve and for possible blockage on inlet filter of the gas valve. 4. Obstruction in the air intake to the fan leading to incorrect CO₂ ratio. Diaphragm is damaged or stucked. 5. Condensate trap is blocked or restricted. Condensate pipe is frozen. 6. Flue is blocked or restricted. 7. Heat exchanger is blocked or restricted. 8. Check the burner for damage. 9. Check the spark electrode or the lead failure. 10. Check the flame sense or the lead failure. 11. Check the rectification ground (black wire to heat exchanger).
228	V	Flame signal without flame present	<p>Tip: Check the ceramic insulator is not damaged, this can cause the spark to earth, twist and pull the ceramic insulator to ensure it is not broken.</p> <ol style="list-style-type: none"> 1. Check the flame sense and the lead and replace if required. 2. Check the earth tags on the boiler and on the electrodes. 3. Check the operation of the siphon and no water collecting in the sump. 4. Replace the air and/or gas ratio control valve. 5. Replace the control unit and/or burner control unit.
229	B	Flame failed during burner operation	<p>Tip: Check the ceramic insulator is not damaged, this can cause the spark to earth, twist and pull the ceramic insulator to ensure it is not broken.</p> <ol style="list-style-type: none"> 1. Check the gas supply to the property and check the working pressure on the gas valve inlet. 2. Check the gas-air ratio. 3. Check the ionisation electrode and the harness for damage or contamination. 4. LPG: Sufficient gas in the tank or recently refilled?
232	B	Boiler locked by external switching contact	<p>External cut off switch not used in UK: Ensure nothing is plugged into red I3 connection.</p> <ol style="list-style-type: none"> 1. Connection plug for external switch contact is not plugged into PCB. 2. There is no feedback voltage at the external safety contact at the condensate lifting pump blocks the heat generator. 3. Switching point for the external temperature monitor is set too low. 4. Connection cable to the external temperature monitor is damaged. 5. External temperature monitor is defective.

Fault code	Fault category	Fault text on the display	Remedy
233	V	Boiler identification module or device electronics faulty	<ol style="list-style-type: none"> 1. Wrong code plug is inserted. 2. Check the code plug is not damaged. 3. Replace the code plug if required.
234	V	Gas valve electrical fault	<ol style="list-style-type: none"> 1. Check the gas supply to the property and the inlet on the gas valve (check drop on inlet). 2. Check the connections on the gas valve and the board (loose connection). 3. Check the continuity down harness and replace if required. 4. Check the voltage to the gas valve (19–24 V DC approx. when demand). 5. Check for water on the gas valve connections. 6. Check the resistance on the gas valve (pins 1–2 approx. 69, 5 Ohms). 7. Replace the gas valve if resistances are incorrect. 8. If all tests are correct: replace the PCB.
235	V	Conflicting versions of boiler electr. and boiler identification	Replace the code plug or the burner control.
237	V	System fault	<ol style="list-style-type: none"> 1. Check the code plug is not damaged. 2. Replace the code plug if required. 3. Replace the control unit (PCB).
238	V	Boiler electronics faulty	<ol style="list-style-type: none"> 1. Check the gas supply to the property and the inlet on the gas valve (check drop on inlet). 2. Check the connections on the gas valve and the board (loose connection). 3. Check the continuity down harness and replace if required. 4. Check the voltage to the gas valve (19–24 V DC approx. when demand). 5. Check for water on the gas valve connections. 6. Check the resistance on the gas valve (pins 1–2 approx. 69, 5 Ohms). 7. If all tests are correct: replace the PCB.
242		Boiler electr. system fault	<ol style="list-style-type: none"> 1. Restart the appliance to see if the problem re-occurs. 2. If the fault remains after resetting: the burner controller (PCB) is defective.
244 245 249 250 251 252 253 254 258		System fault boiler electronics / basic controller	<ol style="list-style-type: none"> 1. Restart the appliance to see if the problem re-occurs. 2. Check the electrical connections on the board (check for loose wires etc.). 3. Check the code plug is not damaged. 4. Replace the code plug if required. 5. Replace the control unit (PCB).
257 259	V	System fault boiler electronics / basic controller	<ol style="list-style-type: none"> 1. Restart the appliance to see if the problem re-occurs. 2. Check the electrical connections on the board (check for loose wires etc.). 3. Check the code plug is not damaged. 4. Replace the code plug if required. 5. Replace the control unit (PCB).
262 263	V	System fault boiler electronics / basic controller	<ol style="list-style-type: none"> 1. Restart the appliance to see if the problem re-occurs. 2. Check the electrical connections on board (check for loose wires etc.). 3. Check the code plug is not damaged. 4. Replace the code plug if required. 5. Replace the control unit (PCB).
265	B	Heat demand lower than energy supplied	Not applicable, operating message, is not a fault.
268	O	Relay test was activated	Not applicable, status message.
269	V	Flame monitoring	<ol style="list-style-type: none"> 1. Restart the appliance to see if the problem re-occurs. 2. Check the electrical connections on the board (check for loose wires etc.). 3. Replace the control unit (PCB).
273	B	Operation of burner and fan interrupted	Not applicable, status message.
281	B	Pump stuck or running in air	<ol style="list-style-type: none"> 1. Check the flow pressure in system. 2. Check the system for circulation issues (air locks, blockage, restriction). 3. Check that the tacho cable plug for the circulation pump is fitted correctly. 4. Check the tacho cable for continuity and replace the tacho cable if required. 5. Replace the pump.
283	O	Burner starting	Operating message, is not a fault.

Fault code	Fault category	Fault text on the display	Remedy
284	O	Opening air/gas ratio control valve/oil solenoid valves	Operating message, is not a fault.
305	O	Boiler in hot water anti-cycle mode	Anti-fast cycle mode, domestic hot water keep warm function. 1. Diverter valve is held in the hot water position for a period of time. 2. Check for false demands on the cold water inlet.
306	V	Flame signal after closing the fuel supply	Tip: Ensure the working pressure returns immediately to the standing pressure when the gas valve closes. 1. Check the gas supply to the property and the inlet on the gas valve (check drop on inlet). 2. Check the gas valve is not passing and replace if required. 3. Replace the PCB.
357	O	Ventilation program	Operating message, is not a fault: Venting program has been activated.
358	O	Anti-seizing functn. active	Operating message, is not a fault: blocking protection for the heating pump and the 3-way valve is active.
360	V	System fault boiler electronics / basic controller	1. Wrong code plug is inserted. 2. Check the code plug is not damaged. 3. Replace the code plug if required.
362	V	Boiler identification module or boiler electronics faulty	1. Wrong code plug is inserted. 2. Check the code plug is not damaged. 3. Replace the code plug if required.
363	V	System fault boiler electronics / basic controller	1. Check and replace the ionisation cable. 2. Check and replace the electrodes if required. 3. Check and replace the control unit and/or burner control unit.
604		System fault burner control unit	1. Restart the appliance to see if the problem re-occurs. 2. If the fault remains after resetting: the burner controller (PCB) is defective.
815	W	Low loss header temp. sensor faulty	Tip: Check menu has not been accidentally switched on. Moisture on the connectors – PCB fault.
1010	O	No communication via EMS BUS connection	1. Check the HMI for display and remove the HMI and the test voltage to the HMI. 2. Check the white HMI plug on far right of the PCB (low voltage connection). 3. If using the Key: Check the Key connections (black, white, red, green) are plugged in to the correct position on the PCB. (Next to orange BUS connection leaving one space.) Check the pins on the plug. 4. Check the bridging links are in LR & 230 V out. 5. Replace the board. 6. Occasionally the Key connection (green flap) can cause this. 7. Check the 230 V external wiring does not run alongside the BUS connections.
1013		Max. combustion point reached	1. Check the maintenance menu. 2. Reset the maintenance code via the reset menu.
1017	W	System pressure too low	1. Top up water and vent the system. 2. Check the voltage to the pressure sensor and the signal back from the pressure sensor. 3. Replace the pressure sensor.
1018		Maintenance interval expired	1. Check the maintenance date set in the menu. 2. Reset the maintenance code via the reset menu.
1019		Incorrect pump type detected	1. Pump communication failure or wrong pump is fitted (non-ErP). 2. Check the pump communication wire is connected and has continuity. 3. Replace the pump for correct modulating pump.
1021	B	Cylinder charging or hot water temperature sensor faulty	1. Check the domestic hot water temperature sensor connected and the plug connected to temperature sensor. 2. Check the resistance of the temperature sensor and replace if required. 3. Check the continuity of harness and replace if required.
1023		Maximum run time including standby time reached	1. Check the maintenance menu. 2. Reset the maintenance code via the reset menu.
1025		Return temp. sensor is faulty	Not fitted on the boiler.

Fault code	Fault category	Fault text on the display	Remedy
1037	W	Outside temp. sensor faulty - heating back-up operation active	Tip: Check the weather compensation is applicable and the menu has not been accidentally switched on in the menu. 1. Check the positioning of the outside weather sensor. 2. Check the weather sensor connections on the control board. 3. Check the resistance of the sensor and the continuity down the cable and replace if required.
1065	B	System pressure sensor faulty or not connected	1. Check the water pressure sensor plug is connected. 2. Plug the connection plug on the water pressure sensor correctly. 3. Check the continuity of harness and replace if required. 4. Check the voltage to the pressure sensor and the return voltage to the pressure sensor. 5. Replace the pressure sensor.
1068	W	Outside temp. sensor or lambda probe faulty.	1. Check the outdoor sensor plug is connected. 2. Check the resistance of the sensor and replace if required. 3. Check the continuity of harness and replace if required. 4. Replace the outdoor sensor.
1070		Maintenance is due on <dd.mm.yyyy> please call your service engineer	Advanced service reminder warning. 1. Check the maintenance menu. 2. Reset the maintenance code via the reset menu.
1071		Maintenance is now due please call your service engineer	1. Check the maintenance menu. 2. Reset the maintenance code via the reset menu.
1072		Maintenance is overdue please call your service engineer	1. Check the maintenance menu. 2. Reset the maintenance code via the reset menu.
1075	W	Heat exchanger temp sensor short circuit	1. Check the temperature sensor plug is connected. 2. Check the resistance of sensor and replace if required. 3. Check the continuity of harness and replace if required. 4. Replace the temperature sensor. 5. Replace the PCB.
1076	W	Heat exchanger temp sensor disconnected	1. Replace the temperature sensor plug is connected. 2. Check the resistance of sensor and replace if required. 3. Check the continuity of harness and replace if required. 4. Replace the temperature sensor. 5. Replace the PCB.
2085	V	Internal fault	1. Reset the appliance. 2. Switch off the appliance for 30 s then turn back on. 3. Check the incoming mains voltage. 4. Check the polarity. 5. Replace the PCB.
2908	V	System fault boiler electronics / basic controller	1. Restart the appliance to see if the problem re-occurs. 2. If the fault remains after resetting: the burner controller (PCB) is defective and must be replaced.
2910	V	Fault in flue system	1. Check the flue for obstructions and remove any found. 2. Check the flue integrity test. 3. Check for water in the sump and check the siphon operation.
2914 2915 2916		Boiler electr. system fault	1. Restart the appliance to see if the problem re-occurs. 2. If the fault remains after resetting: the burner controller (PCB) is defective.
2920	V	Fault in flame monitoring	Possible PCB fault, no checks available.
2923 2924 2925 2926 2927	V	Boiler electr. system fault	1. Check the voltage to the gas valve. 2. Check the resistance of the gas valve coils. 3. Check the continuity of harness and replace if required. 4. The gas valve or the PCB may have a fault.
2928		Internal fault	1. Restart the appliance to see if the problem re-occurs. 2. If the fault remains after resetting: the burner controller (PCB) is defective.
2931		System fault boiler electronics / basic controller	1. Restart the appliance to see if the problem re-occurs. 2. If the fault remains after resetting: the burner controller (PCB) is defective.

Fault code	Fault category	Fault text on the display	Remedy
2940	V	System fault burner control unit	<ol style="list-style-type: none"> 1. Restart the appliance to see if the problem re-occurs. 2. If the fault remains after resetting: the burner controller (PCB) is defective.
2946	V	Incorrect code plug detected	<ol style="list-style-type: none"> 1. Check the code plug and the part number. 2. Check the code plug connections for damage. 3. Replace the code plug.
2948	B	No flame signal with low output	<p>The burner starts automatically after purging. It may cause strong winds.</p> <ol style="list-style-type: none"> 1. If the fault occurs repeatedly: check the settings of the CO₂ values. 2. Check the flue integrity. 3. Check the flue terminal.
2949	B	No flame signal with high output	<p>It may cause strong winds or flue gas recirculation. The burner starts automatically after purging.</p> <ol style="list-style-type: none"> 1. Check the flue integrity. 2. Check the flue terminal position. 3. Check the CO₂ settings and adjust. 4. Check the burner and the heat exchanger gaskets and the inner flue gaskets. 5. Check the gas pressure during burning at full load (working pressure, dropping low).
2950	B	No flame signal following starting procedure	<ol style="list-style-type: none"> 1. Check the CO₂ settings and adjust. 2. Check the burner and the heat exchanger gaskets. 3. Check the gas pressure during burning at full load. 4. Burner restarts automatically after purging.
2951	V	Loss of flame too many times	<p>Note: Combustion case off can cause this fault.</p> <ol style="list-style-type: none"> 1. Refer to blocking errors(s) that lead to this locking error. Check the fault history on the appliance. 2. Possibly the purging of the gas pipe is incomplete. 3. It could also indicate a wide variety of issues such as pipework undersized or gas pressure dropping off, incorrectly routed condens drains, incorrectly sited flues, incorrectly wired etc.
2952	V	Internal fault when testing the ionisation signal	<ol style="list-style-type: none"> 1. Restart the appliance to see if the problem re-occurs. 2. If the fault remains after resetting: the burner controller (PCB) is defective.
2955	B	Boiler does not support the parameters set for the hydraulic configuration	<p>Verify that the following settings are correct. This can only be reset by powering off the appliance.</p> <ol style="list-style-type: none"> 1. Low loss header setting = OFF 2. Internal DHW hydraulic = 1/ON 3. Heat circuit 1 hydraulic = 1/ON 4. CH hydraulic = 1/ON
2956	O	Hydraulic configuration at the boiler activated	<p>Verify that the following settings are correct. This can only be reset by powering off the appliance.</p> <ol style="list-style-type: none"> 1. Low loss header setting = OFF 2. Internal DHW hydraulic = 1/ON 3. Heat circuit 1 hydraulic = 1/ON 4. CH hydraulic = 1/ON
2957	V	Boiler electr. system fault	<ol style="list-style-type: none"> 1. Restart the appliance to see if the problem re-occurs. 2. If the fault remains after resetting: the burner controller (PCB) is defective and must be replaced.
2961 2962	V	No fan signal available	<ol style="list-style-type: none"> 1. Check the mains voltage to the fan. 2. Check the fan harness for continuity and replace if required. 3. Check the pulse width modulation (PWM). 4. Replace the fan. 5. Replace the PCB.
2963	B	The heat exchanger sensor or both supply and heat exchanger sensors are defect	<ol style="list-style-type: none"> 1. Check the flow through the appliance and the system is filled. 2. Check for air locks in the system and purge if required. 3. Check the heat exchanger sensor (primary thermistor) and the plug connected to temperature sensor. 4. Check the resistance of the temperature sensor and replace if required. 5. Check the continuity of harness and replace if required.

Fault code	Fault category	Fault text on the display	Remedy
2965	B	Flow temperature too high	<ol style="list-style-type: none"> 1. Check the flow through the appliance and the system is filled. 2. Check for the air locks in the system and purge if required. 3. Check the isolation valves.
2966	B	Flow temperature rise in heat exchanger too rapid	<ol style="list-style-type: none"> 1. Check the flow through the appliance and the system is filled. 2. Check for the air locks in the system and purge if required. 3. Check the isolation valves. 4. Check the pump is operating freely and check the voltage to the pump.
2968	O	Refilling system pressure	The auto filling function is active. The filling valve opens in order to feed fresh water to the heating system automatically.
2969		Maximum number of refills reached	The maximum number of refills has been reached.
2970	B	Pressure drop in heating system too rapid	<p>Too many unexpected pressure drops within a short time period.</p> <ol style="list-style-type: none"> 1. Cause code can appear if system is pressurised and the intelligent filling loop activated and then the system vented. 2. Switch off the intelligent fill in the system menu, re-pressurise manually and vent the system. 3. Ensure the correct pressure. If cause code does not clear power off appliance.
2971	B	System pressure too low	<p>Compare to internal pressure dial max. 0.5 bar pressure differential between them. Top up water until the pre-set pressure reached.</p> <p>Intelligent filling loop</p> <ol style="list-style-type: none"> 1. Switch off the intelligent fill in the system menu, re-pressurise manually and vent the system. 2. Ensure the correct pressure then factory rest appliance. If cause code does not clear power off appliance. <p>Other filling loop</p> <p>Vent the heating system and top up water until the pre-set pressure reached.</p> <p>Pressure sensor</p> <ol style="list-style-type: none"> 1. Check the continuity down harness for the pressure sensor and replace if required. 2. Check the voltage at the pressure sensor and replace if required.
2972		Mains voltage too low	Check the mains voltage on the appliance (L and N).

Table 27 Indicators and fault displays

10.1.3 Faults that are not displayed

Appliance faults	Remedy
Combustion noises too loud; rumbling noises	<ul style="list-style-type: none"> ▶ Check the gas type. ▶ Check the gas supply pressure. ▶ Check the flue system; clean or repair if required. ▶ Check the gas/air ratio. ▶ Check the air/gas ratio control valve; replace if required.
Flow noises	<ul style="list-style-type: none"> ▶ Set the pump rate or pump characteristic map correctly and match to the maximum output.
Heat-up takes too long.	<ul style="list-style-type: none"> ▶ Set the pump rate or pump characteristic map correctly and match to the maximum output.
Flue gas values incorrect; CO content too high.	<ul style="list-style-type: none"> ▶ Check the gas type. ▶ Check the gas supply pressure. ▶ Check the flue system; clean or repair if required. ▶ Check the gas/air ratio. ▶ Check the air/gas ratio control valve; replace if required.
Violent ignition, poor ignition.	<ul style="list-style-type: none"> ▶ Check the ignition transformer with service function t01 for misfiring, replace if required. ▶ Check the gas type. ▶ Check the gas supply pressure. ▶ Check the power supply. ▶ Check the electrodes with cable; replace if required. ▶ Check the flue system; clean or repair if required. ▶ Check the gas/air ratio. ▶ For natural gas: check the external gas flow monitor, replace if required. ▶ Check the burner, replace if required. ▶ Check the air/gas ratio control valve; replace if required.
Condensate in air box	<ul style="list-style-type: none"> ▶ Check the non-return valve in the air-gas manifold, replace if required.
Combi boilers: hot water outlet temperature is not reached.	<ul style="list-style-type: none"> ▶ Check the turbine, replace if required. ▶ Check the gas/air ratio.
Combi boilers: DHW volume is not reached.	<ul style="list-style-type: none"> ▶ Check the plate heat exchanger.
No function, the display remains dark.	<ul style="list-style-type: none"> ▶ Check the electrical wiring for damage. ▶ Replace defective cables. ▶ Check the fuse, replace if required.

Table 28 Faults that are not shown on the display

System gassing



WARNING

If you suspect the heating system is gassing, you must exercise caution when carrying out testing or remedial work as the gasses produced can be flammable.

Do not vent air from radiators whilst the central heating is switched on. Allow 30mins after venting the radiators before using the central heating or hot water.

- ▶ Whilst venting radiators, do not allow the pressure on the boiler to drop below the point at which it is normally set.
- ▶ If the system is to be drained, the boiler must be electrically isolated.



CAUTION

If system pressure is repeatedly increasing, even when the appliance is not operating, you should first check that the filling link is fully closed and confirm that it is not passing. If radiators are also not heating to the top of the panels and repeatedly need venting, the heating system may be suffering from gassing. This is an indication that corrosion is taking place and requires the system being cleaned and treated to BS7593:2019.

- ▶ This should be confirmed by taking water samples to check pH levels and turbidity.
- ▶ Failure to properly maintain the heating system may result in damage to the system and appliance, and may affect the boiler warranty.

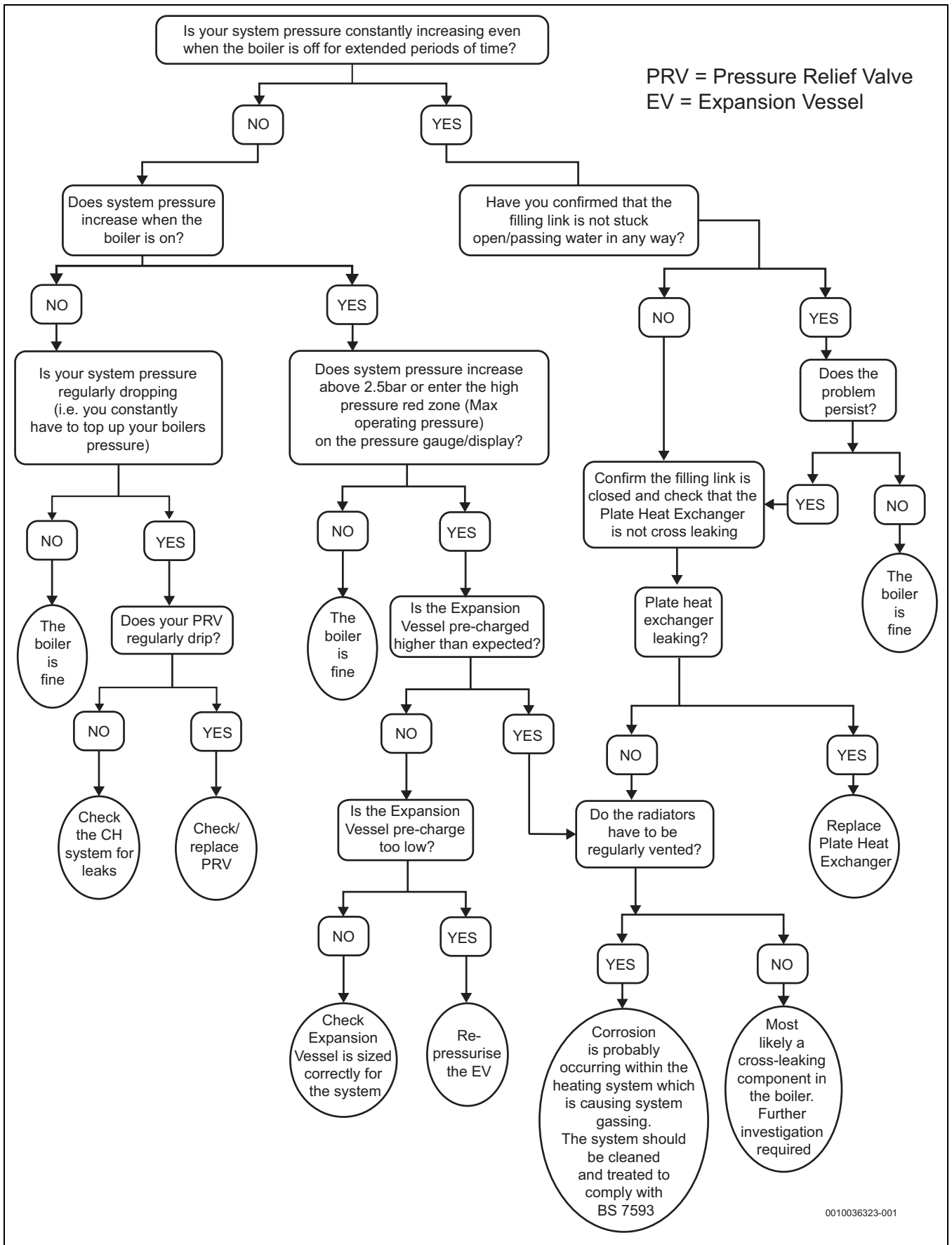

0010036323-001

Fig. 115 System gassing flow chart

11 Environmental protection and disposal

Environmental protection is a fundamental corporate strategy of the Bosch Group.

The quality of our products, their economy and environmental safety are all of equal importance to us and all environmental protection legislation and regulations are strictly observed.

We use the best possible technology and materials for protecting the environment taking account of economic considerations.

Packaging

Where packaging is concerned, we participate in country-specific recycling processes that ensure optimum recycling.

All of our packaging materials are environmentally compatible and can be recycled.

Used appliances

Used appliances contain valuable materials that can be recycled.

The various assemblies can be easily dismantled. Synthetic materials are marked accordingly. Assemblies can therefore be sorted by composition and passed on for recycling or disposal.

Old electrical and electronic appliances



This symbol means that the product must not be disposed of with other waste, and instead must be taken to the waste collection points for treatment, collection, recycling and disposal.

The symbol is valid in countries where waste electrical and electronic equipment regulations apply, e.g. "European Directive 2012/19/EC on old electronic and electrical appliances". These regulations define the framework for the return and recycling of old electronic appliances that apply in each country.

As electronic devices may contain hazardous substances, it needs to be recycled responsibly in order to minimize any potential harm to the environment and human health. Furthermore, recycling of electronic scrap helps preserve natural resources.

For additional information on the environmentally compatible disposal of old electrical and electronic appliances, please contact the relevant local authorities, your household waste disposal service or the retailer where you purchased the product.

You can find more information here:

www.weee.bosch-thermotechnology.com/

Batteries

Batteries must not be disposed together with your household waste.

Used batteries must be disposed of in local collection systems.

12 Technical Specifications/Logs

12.1 Technical data

The new boiler is set at the maximum output and should be adjusted when it is installed and commissioned. In accordance with the standards, the declared space heating efficiency, useful efficiency and NO_x values efficiency for this range rated boiler are not measured at the maximum output. To achieve the published efficiency and NO_x values, the gas rate should be reduced.

12.1.1 Specifications Combi

Greenstar 8000 Style

	Unit	GR8700iW 30		GR8700iW 35	
		Natural Gas	Propane ¹⁾	Natural Gas	Propane ¹⁾
Gas flow maximum rate – 10 min from lighting					
Natural Gas (NG) ²⁾	m ³ /h	3.2	–	3.6	–
Propane Gas (LPG)	kg/h	–	2.3	–	2.7
Central Heating (CH range rated)³⁾					
Heat input, modulation range (net)	kW	3.0 – 30.2	3.0 – 30.2	5.1 – 34.4	5.1 – 34.4
Heat input, adjustment range (net), Q _n	kW	15.1 – 30.2	15.1 – 30.2	17.2 – 34.4	17.2 – 34.4
Heat output, 40/30 °C, adjustment range	kW	15.6 – 31.2	15.6 – 31.2	17.6 – 35.2	17.6 – 35.2
Heat output, 50/30 °C, adjustment range, P _{cond}	kW	15.5 – 31.0	15.5 – 31.0	17.5 – 35.0	17.5 – 35.0
Heat output, 80/60 °C, adjustment range, P _n	kW	14.8 – 29.6	14.8 – 29.6	16.9 – 33.7	16.9 – 33.7
Maximum flow temperature	°C	70	70	70	70
Maximum flow temperature possible	°C	82	82	82	82
Maximum permissible operating pressure (PMS)	bar	2.5	2.5	2.5	2.5
Available pump head at 20 K (°C) system temperature rise	m	2.0	2.0	2.0	2.0
Domestic Hot Water DHW					
Heat input, modulation range (net)	kW	3.0 – 30.2	3.0 – 30.2	5.1 – 34.4	5.1 – 34.4
Rated heat input (net) Q _{nW}	kW	30.2	30.2	34.4	34.4
Rated heat output P _{nW}	bar	30.2	30.2	34.4	34.4
Minimum mains inlet pressure (working) for max. flow	bar	2.3	2.3	3.2	3.2
Minimum mains inlet pressure (working) for operation	bar	0.2	0.2	0.2	0.2
Minimum required flow to activate DHW demand	l/min	1.9	1.9	1.9	1.9
DHW temperature range	°C	35 – 60	35 – 60	35 – 60	35 – 60
Maximum cold water inlet temperature	°C	60	60	60	60
Maximum DHW flow rate – 40 °C rise ± 15% ⁴⁾	l/min	11	11	13	13
Flue					
Flue gas temperature max. load DHW demand	°C	67/56	67/56	72/56	72/56
Flue gas temperature 80/60 °C, max./min. load	°C	67/56	67/56	72/56	72/56
Flue gas temperature 40/30 °C, max./min. load	°C	49/31	49/31	52/31	52/31
CO ₂ level at max. rated heat output (after 10 min)	%	9.5	10.8	9.5	10.8
CO ₂ level at min. rated heat output (after 10 min)	%	8.6	10.2	8.6	10.2
NO _x class at range rated output ³⁾	–	6	6	6	6
NO _x rating (EN 15502-1) at range rated output ³⁾	mg/kWh	≤ 40	≤ 40	≤ 40	≤ 40
Condensate					
Maximum condensate rate	l/h	3.5	3.5	4.1	4.1
pH value, approx.	–	4.5 – 5.0	4.5 – 5.0	4.5 – 5.0	4.5 – 5.0
Electrical					
Electrical power supply voltage	a.c. V	230	230	230	230
Frequency	Hz	50	50	50	50
Maximum power consumption (running)	W	150	150	108	108
Maximum power consumption (stand-by)	W	1	1	1	1
Energy efficiency index (EEI) heating pump	–	≤ 0.23	≤ 0.23	≤ 0.23	≤ 0.23
General data					
Expansion vessel capacity	l	10.0	10.0	10.0	10.0
Expansion vessel pre-charge pressure	bar	0.75	0.75	0.75	0.75

	Unit	GR8700iW 30		GR8700iW 35	
		Natural Gas	Propane ¹⁾	Natural Gas	Propane ¹⁾
Appliance protection rating ⁵⁾	IP	X4D	X4D	X4D	X4D
Permissible ambient temperature short time/long time	°C	0 – 50/40	0 – 50/40	0 – 50/40	0 – 50/40
Nominal capacity of the appliance	l	5.2	5.2	5.2	5.2
Total packaged weight	kg	55	55	55	55
Total appliance weight (excluding packaging)	kg	47	47	47	47
Lift weight (without front and side panels)	kg	41	41	41	41

- 1) Propane/butane mixture for fixed containers with capacity up to 15,000 l.
- 2) The Gas Rate provided assumes the accepted NG average calorific value of 34.9 MJ/m³ net.
- 3) Range rated value for efficiency and NO_x. To achieve the NO_x values stated in this table, the heating output must be capped. Refer to → page 88.
- 4) Appliances are fitted with a flow regulator set to achieve a 40 °C temperature rise. This ensures comfortable bathing during the colder winter months.
- 5) Protection rating may change depending on the control unit/s used on this appliance.

Table 29 GR8700iW 30 and GR8700iW 35

	Unit	GR8700iW 40		GR8700iW 45	
		Natural Gas	Propane ¹⁾	Natural Gas	Propane ¹⁾
Gas flow maximum rate – 10 min from lighting					
Natural Gas (NG) ²⁾	m ³ /h	4.3	–	4.6	–
Propane Gas (LPG)	kg/h	–	3.2	–	3.4
Central Heating (CH range rated)³⁾					
Heat input, modulation range (net)	kW	5.1 – 34.4	5.1 – 34.4	6.3 – 34.4	6.3 – 34.4
Heat input, adjustment range (net), Q _n	kW	17.2 – 34.4	17.2 – 34.4	17.2 – 34.4	17.2 – 34.4
Heat output, 40/30 °C, adjustment range	kW	17.6 – 35.2	17.6 – 35.2	18.0 – 36.0	18.0 – 36.0
Heat output, 50/30 °C, adjustment range, P _{cond}	kW	17.5 – 35.0	17.9 – 35.0	17.9 – 37.7	17.9 – 37.7
Heat output, 80/60 °C, adjustment range, P _n	kW	16.9 – 33.7	16.9 – 33.7	16.9 – 33.8	16.9 – 33.8
Maximum flow temperature	°C	70	70	70	70
Maximum flow temperature possible	°C	82	82	82	82
Maximum permissible operating pressure (PMS)	bar	2.5	2.5	2.5	2.5
Available pump head at 20 K (°C) system temperature rise	m	2.0	2.0	2.0	2.0
Domestic Hot Water DHW					
Heat input, modulation range (net)	kW	5.1 – 40.8	5.1 – 40.8	6.3 – 43.5	6.3 – 43.5
Rated heat input (net), Q _{nW}	kW	40.8	40.8	43.5	43.5
Rated heat output, P _{nW}	kW	40.8	40.8	43.5	43.5
Maximum mains inlet pressure (standing pressure PMW)	bar	10	10	10	10
Minimum mains inlet pressure (working) for max. flow	bar	2.0	2.0	2.2	2.2
Minimum mains inlet pressure (working) for operation	bar	0.2	0.2	0.2	0.2
Minimum required flow to activate DHW demand	l/min	1.9	1.9	1.9	1.9
DHW temperature range	°C	35–60	35–60	35–60	35–60
Maximum cold water inlet temperature	°C	60	60	60	60
Maximum DHW flow rate –40 °C rise ± 15% ⁴⁾	l/min	14	14	15	15
Flue					
Flue gas temperature max. load DHW demand	°C	77/56	77/56	69/56	69/56
Flue gas temperature 80/60 °C, max./min. load	°C	77/56	77/56	69/56	69/56
Flue gas temperature 40/30 °C, max./min. load	°C	56/31	56/31	52/30	52/30
CO ₂ level at max. rated heat output (after 10 min)	%	9.5	10.8	9.5	10.8
CO ₂ level at min. rated heat output (after 10 min)	%	8.6	10.2	8.6	10.2
NO _x class at range rated output ³⁾	–	6	6	6	6
NO _x rating (EN 15502-1) at range rated output ³⁾	mg/kWh	≤ 40	≤ 40	≤ 40	≤ 40
Condensate					
Maximum condensate rate	l/h	4.1	4.1	4.1	4.1
pH value, approx.	–	4.5 – 5.0	4.5 – 5.0	4.5 – 5.0	4.5 – 5.0
Electrical					
Electrical power supply voltage	a.c. V	230	230	230	230
Frequency	Hz	50	50	50	50
Maximum power consumption (running)	W	130	130	130	130

	Unit	GR8700iW 40		GR8700iW 45	
		Natural Gas	Propane ¹⁾	Natural Gas	Propane ¹⁾
Maximum power consumption (stand-by)	W	1	1	1	1
Energy efficiency index (EEl) heating pump	-	≤ 0.23	≤ 0.23	≤ 0.23	≤ 0.23
General data					
Expansion vessel capacity	l	10.0	10.0	10.0	10.0
Expansion vessel pre-charge pressure	bar	0.75	0.75	0.75	0.75
Appliance protection rating ⁵⁾	IP	X4D	X4D	X4D	X4D
Permissible ambient temperature short time/long time	°C	0 – 50/40	0 – 50/40	0 – 50/40	0 – 50/40
Nominal capacity of the appliance	l	5.2	5.2	5.9	5.9
Total packaged weight	kg	55	55	57	57
Total appliance weight (excluding packaging)	kg	47	47	49	49
Lift weight (without front and side panels)	kg	41	41	43	43

- 1) Propane/butane mixture for fixed containers with capacity up to 15,000 l.
- 2) The Gas Rate provided assumes the accepted NG average calorific value of 34.9 MJ/m³ net.
- 3) Range rated value for efficiency and NO_x. To achieve the NO_x values stated in this table, the heating output must be capped. Refer to → page 88.
- 4) Appliances are fitted with a flow regulator set to achieve a 40 °C temperature rise. This ensures comfortable bathing during the colder winter months.
- 5) Protection rating may change depending on the control unit/s used on this appliance.

Table 30 GR8700iW 40 and GR8700iW 45

	Unit	GR8700iW 50	
		Natural Gas	Propane ¹⁾
Gas flow maximum rate – 10 min from lighting			
Natural Gas (NG) ²⁾	m ³ /h	5.1	-
Propane Gas (LPG)	kg/h	-	3.8
Central Heating (CH range rated)³⁾			
Heat input, modulation range (net)	kW	6.3 – 34.4	6.3 – 34.4
Heat input, adjustment range (net), Q _n	kW	17.2 – 34.4	17.2 – 34.4
Heat output, 40/30 °C, adjustment range	kW	18.0 – 36.0	18.0 – 36.0
Heat output, 50/30 °C, adjustment range, P _{cond}	kW	17.9 – 35.7	17.9 – 35.7
Heat output, 80/60 °C, adjustment range, P _n	kW	16.9 – 33.8	16.9 – 33.8
Maximum flow temperature	°C	70	70
Maximum flow temperature possible	°C	82	82
Maximum permissible operating pressure (PMS)	bar	2.5	2.5
Available pump head at 20 K (°C) system temperature rise	m	2.0	2.0
Domestic Hot Water DHW			
Heat input, modulation range (net)	kW	6.3 – 48.9	6.3 – 48.9
Rated heat input (net) Q _{nW}	kW	48.9	48.9
Rated heat output P _{nW}	bar	48.9	48.9
Maximum mains inlet pressure (standing pressure PMW)	bar	10	10
Minimum mains inlet pressure (working) for max. flow	bar	2.5	2.5
Minimum mains inlet pressure (working) for operation	bar	0.2	0.2
Minimum required flow to activate DHW demand	l/min	1.9	1.9
DHW temperature range	°C	35 – 60	35 – 60
Maximum cold water inlet temperature	°C	60	60
Maximum DHW flow rate –40 °C rise ± 15% ⁴⁾	l/min	18	18
Flue			
Flue gas temperature max. load DHW demand	°C	73/56	73/56
Flue gas temperature 80/60 °C, max./min. load	°C	73/56	73/56
Flue gas temperature 40/30 °C, max./min. load	°C	55/30	55/33
CO ₂ level at max. rated heat output (after 10 min)	%	9.5	10.8
CO ₂ level at min. rated heat output (after 10 min)	%	8.6	10.2
NO _x class at range rated output ³⁾	-	6	6
NO _x rating (EN 15502-1) at range rated output ³⁾	mg/kWh	≤ 40	≤ 40
Condensate			
Maximum condensate rate	l/h	4.1	4.1

	Unit	GR8700iW 50	
		Natural Gas	Propane ¹⁾
pH value, approx.	-	4.5 – 5.0	4.5 – 5.0
Electrical			
Electrical power supply voltage	a.c. V	230	230
Frequency	Hz	50	50
Maximum power consumption (running)	W	143	143
Maximum power consumption (stand-by)	W	1	1
Energy efficiency index (EEI) heating pump	-	≤ 0.23	≤ 0.23
General data			
Expansion vessel capacity	l	10.0	10.0
Expansion vessel pre-charge pressure	bar	0.75	0.75
Appliance protection rating ⁵⁾	IP	X4D	X4D
Permissible ambient temperature short time/long time	°C	0 – 50/40	0 – 50/40
Nominal capacity of the appliance	l	5.9	5.9
Total packaged weight	kg	57	57
Total appliance weight (excluding packaging)	kg	49	49
Lift weight (without front and side panels)	kg	43	43

- 1) Propane/butane mixture for fixed containers with capacity up to 15,000 l.
- 2) The Gas Rate provided assumes the accepted NG average calorific value of 34.9 MJ/m³ net.
- 3) Range rated value for efficiency and NO_x. To achieve the NO_x values stated in this table, the heating output must be capped. Refer to → page 88.
- 4) Appliances are fitted with a flow regulator set to achieve a 40 °C temperature rise. This ensures comfortable bathing during the colder winter months.
- 5) Protection rating may change depending on the control unit/s used on this appliance.

Table 31 GR8700iW 50

12.2 Ionisation current

Type	Gas type	When the burner is running at a minimum rated heat	
		OK	Faulty
GR8700iW 30	NG	≥ 3 μA	< 3 μA
	LPG	≥ 3 μA	< 3 μA
GR8700iW 35, GR8700iW 40, GR8700iW 45, GR8700iW 50	NG	≥ 7 μA	< 7 μA
	LPG	≥ 10 μA	< 10 μA

Table 32 Ionisation current

12.3 Component resistance characteristics

12.3.1 Sensor values

Temperature [°C ± 10 %]	Resistance [Ω]
-20	2392
-16	2088
-12	1811
-8	1562
-4	1342
0	1149
4	984
8	842
12	720
16	616
20	528
24	454

Table 33 Outside temperature sensor (for weather-compensated control units, accessory)

Temperature [°C ± 10 %]	Resistance [Ω]
0	33 404
5	25 902
10	20 247
15	15 950
20	12 657
25	10 115
30	8 138
35	6 589
40	5 367
45	4 398
50	3 624
55	3 002
60	2 500
65	2 092
70	1 759
75	1 486
80	1 260
85	1 074
90	918.3
95	788.5

Table 34 Flow temperature sensor

12.4 Code plug

Type	Gas type	Number
GR8700iW 30 NG	Natural Gas	20017
GR8700iW 35 NG	Natural Gas	20018
GR8700iW 40 NG	Natural Gas	20019
GR8700iW 45 NG	Natural Gas	20020
GR8700iW 50 NG	Natural Gas	20021
GR8700iW 30 LPG	Liquid Petroleum Gas	20036
GR8700iW 35 LPG	Liquid Petroleum Gas	20037
GR8700iW 40 LPG	Liquid Petroleum Gas	20038
GR8700iW 45 LPG	Liquid Petroleum Gas	20039
GR8700iW 50 LPG	Liquid Petroleum Gas	20040

Table 35 Code plug

12.5 Pump characteristic map of the heating pump

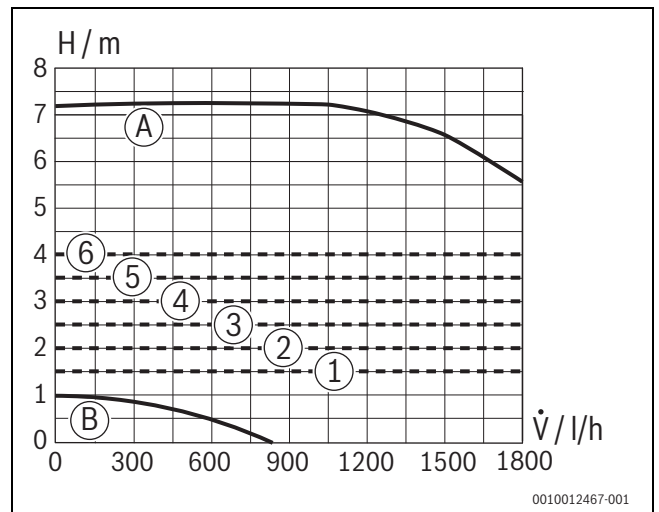

Fig. 116 Pump characteristic maps and pump curves

- [1] Pump characteristic map, constant pressure 150 mbar
- [2] Pump characteristic map, constant pressure 200 mbar
- [3] Pump characteristic map, constant pressure 250 mbar
- [4] Pump characteristic map, constant pressure 300 mbar
- [5] Pump characteristic map, constant pressure 350 mbar
- [6] Pump characteristic map, constant pressure 400 mbar
- [A] Pump curve at maximum pump rate
- [B] Pump curve at minimum pump rate
- H Residual head
- \dot{V} Flow rate

**12.6 Limiting nominal heat output (range rating)
(Settings menu, Heating, Max. heat output)**

Heat output [kW]	Display [%]	Heat input [kW]	Gas volume (NG-G20) [l/min]
14.8	51	15.1	27
16.0*	54	16.4	29
17.0	58	17.5	31
18.0	61	18.5	32
19.0	65	19.5	34
20.0	68	20.5	36
21.0	71	21.5	38
22.0	75	22.5	40
23.0	78	23.5	41
24.0	81	24.6	43
25.0	85	25.6	45
26.0	88	26.6	47
27.0	91	27.6	48
28.0	95	28.6	50
29.0	98	29.6	52
29.6	100	30.2	53

Table 36 GR8700iW 30

[*] Range rated value for efficiency and NO_x. The heating output must be capped at values marked (*) in order to achieve the NO_x values quoted on →page 83.

Heat output [kW]	Display [%]	Heat input [kW]	Gas volume (NG-G20) [l/min]
16.9	50	17.2	30
18.0	53	18.4	32
19.0	56	19.4	34
20.0*	59	20.4	36
21.0	62	21.4	38
22.0	65	22.5	39
23.0	68	23.5	41
24.0	71	24.5	43
25.0	74	25.5	45
26.0	77	26.5	47
27.0	80	27.6	48
28.0	83	28.6	50
29.0	86	29.6	52
30.0	89	30.6	54
31.0	92	31.6	56
32.0	95	32.7	57
33.0	98	33.7	59
33.7	100	34.4	60

Table 37 GR8700iW 35

[*] Range rated value for efficiency and NO_x. The heating output must be capped at values marked (*) in order to achieve the NO_x values quoted on →page 83.

Heat output [kW]	Display [%]	Heat input [kW]	Gas volume (NG-G20) [l/min]
16.9	43	17.2	30
18.0	45	18.4	32
19.0	48	19.4	34
20.0*	50	20.4	36
21.0	53	21.4	38
22.0	55	22.5	39
23.0	58	23.5	41
24.0	60	24.5	43
25.0	63	25.5	45
26.0	65	26.5	47
27.0	68	27.6	48
28.0	70	28.6	50
29.0	73	29.6	52
30.0	75	30.6	54
31.0	78	31.6	56
32.0	80	32.7	57
33.0	83	33.7	59
33.7	84	34.4	60

Table 38 GR8700iW 40

[*] Range rated value for efficiency and NO_x. The heating output must be capped at values marked (*) in order to achieve the NO_x values quoted on →page 83.

Heat output [kW]	Display [%]	Heat input [kW]	Gas volume (NG-G20) [l/min]
16.9	40	17.2	30
18.0	42	18.3	32
19.0	44	19.3	34
20.0*	47	20.3	36
21.0	49	21.4	37
22.0	51	22.4	39
23.0	54	23.4	41
24.0	56	24.4	43
25.0	58	25.4	45
26.0	61	26.4	46
27.0	63	27.5	48
28.0	65	28.5	50
29.0	68	29.5	52
30.0	70	30.5	54
31.0	73	31.5	55
32.0	75	32.6	57
33.0	77	33.6	59
33.8	79	34.4	60

Table 39 GR8700iW 45

[*] Range rated value for efficiency and NO_x. The heating output must be capped at values marked (*) in order to achieve the NO_x values quoted on →page 83.

Heat output [kW]	Display [%]	Heat input [kW]	Gas volume (NG-G20) [l/min]
16.9	35	17.2	30
18.0	37	18.3	32
19.0	40	19.3	34
20.0*	42	20.3	36
21.0	44	21.4	37
22.0	46	22.4	39
23.0	48	23.4	41
24.0	50	24.4	43
25.0	52	25.4	45
26.0	54	26.4	46
27.0	56	27.5	48
28.0	58	28.5	50
29.0	60	29.5	52
30.0	62	30.5	54
31.0	65	31.5	55
32.0	67	32.6	57
33.0	69	33.6	59
33.8	70	34.4	60

Table 40 GR8700iW 50

[*] Range rated value for efficiency and NO_x. The heating output must be capped at values marked (*) in order to achieve the NO_x values quoted on →page 83.

12.7 Electrical wiring

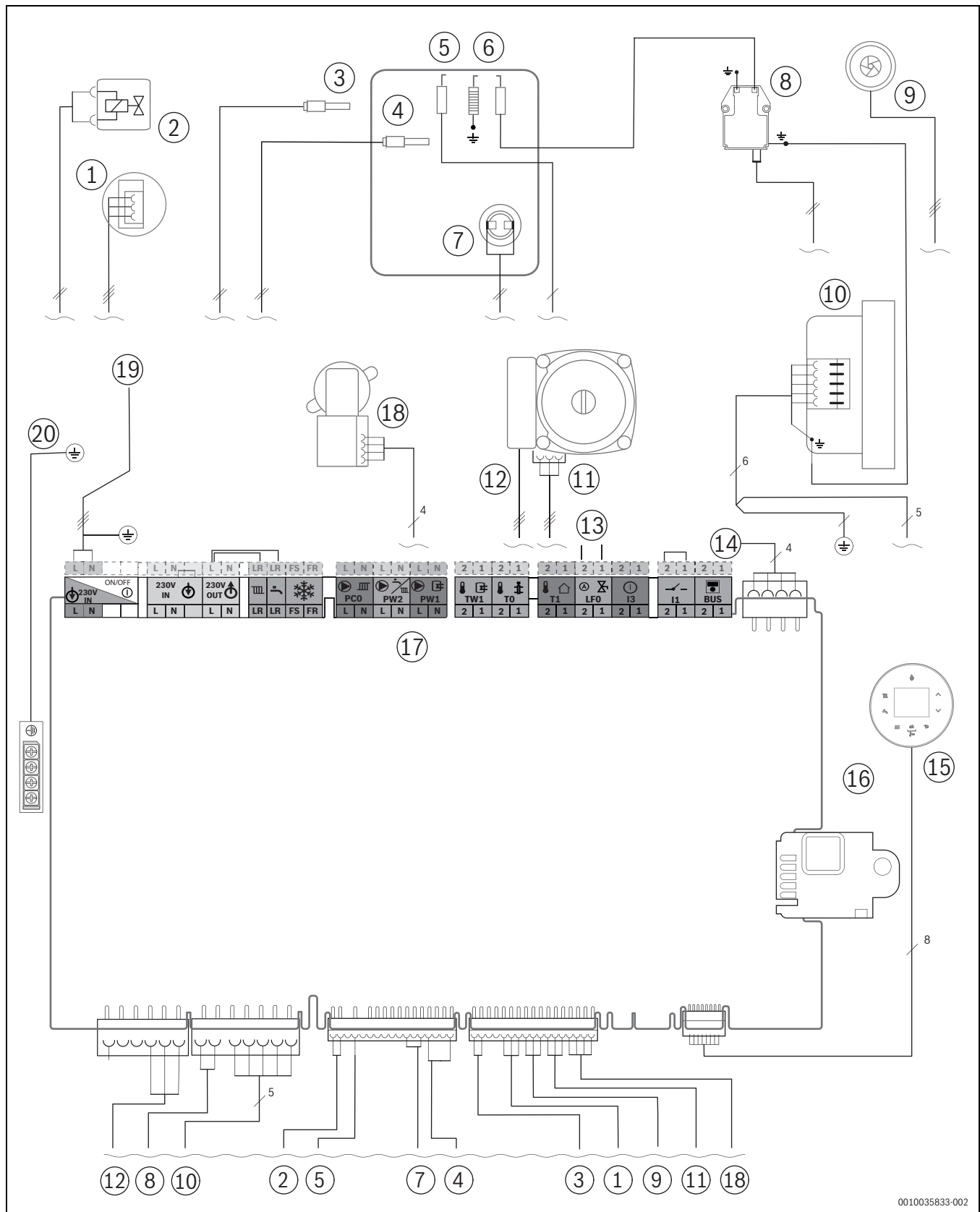

0010035833-002

Fig. 117 Electrical wiring

- [1] Pressure sensor
- [2] Air/gas ratio control valve
- [3] Hot water temperature sensor
- [4] Flow temperature sensor at heating block
- [5] Flame sensing electrode
- [6] Ignition electrode
- [7] Heating block temperature limiter
- [8] Ignition transformer
- [9] Flow turbine
- [10] Fan
- [11] Control cable of the heating pump
- [12] Heating pump 230 V
- [13] Connector for automatic filling device
- [14] Connecting lead for Key slot
- [15] Display
- [16] Code plug
- [17] Terminal strip for external accessories (→ terminal assignment
Tab. 13, page 42)
- [18] 3-way valve
- [19] Connection cable
- [20] Earth bar

GAS BOILER SYSTEM COMMISSIONING CHECKLIST & WARRANTY VALIDATION RECORD

Address:													
Boiler make and model:													
Boiler serial number:													
Commissioned by (PRINT NAME):						Gas Safe registration number:							
Company name:						Telephone number:							
Company email:						Company address:							
										Commissioning date:			
Heating and hot water system complies with the appropriate Building Regulations?											Yes		
Optional: Building Regulations Notification Number (if applicable):													
Time, temperature control and boiler interlock provided for central heating and hot water											Yes		
Boiler Plus requirements (tick the appropriate box(s))													
Boiler Plus option chosen for combination boiler in ENGLAND						Weather compensation			Smart thermostat with automation and optimisation				
						Load compensation			Flue Gas Heat Recovery				
Time and temperature control to hot water		Cylinder thermostat and programmer/timer						Combination boiler					
Zone valves		pre-existing		Fitted		Not required							
Thermostatic radiator valves		pre-existing		Fitted		Not required							
Automatic bypass to system		pre-existing		Fitted		Not required							
Underfloor heating		pre-existing		Fitted		Not required							
Water quality													
The system has been flushed, cleaned and a suitable inhibitor applied upon final fill, in accordance with BS7593 and boiler manufacturers' instructions											Yes		
What system cleaner was used?						Brand:			Product:				
What inhibitor was used?						Brand:			Product:				
Primary water system filter		pre-existing		Fitted		Not required							
CENTRAL HEATING MODE measure and record (as appropriate)													
Gas rate (for combination boilers complete DHW mode gas rate)				m ³ /hr		or		ft ³ /hr					
Central heating output left at factory settings?											Yes	No	
If no, what is the maximum central heating output selected?											kW		
Dynamic gas inlet pressure											mbar		
Central heating flow temperature											°C		
Central heating return temperature											°C		
System correctly balanced/rebalanced?											Yes		
COMBINATION BOILERS ONLY													
Is the installation in a hard water area (above 200ppm)?											Yes	No	
Water scale reducer/softener		pre-existing		Fitted		Not required							
What type of scale reducer/softener has been fitted?						Brand:			Product:				
Water meter fitted?											Yes	No	
If yes- DHW expansion vessel		pre-existing		Fitted		Not required							
Pressure reducing valve		pre-existing		Fitted		Not required							
DOMESTIC HOT WATER MODE Measure and record													
Gas rate				m ³ /hr		or		ft ³ /hr					
Dynamic gas inlet pressure at maximum rate											mbar		
Cold water inlet temperature											°C		
Hot water has been checked at all outlets											Yes	Temperature	°C
CONDENSATE DISPOSAL													
The condensate drain has been installed in accordance with the manufacturers' instructions and/or BS5546/BS6798											Yes		
Point of termination						Internal			External (only where internal termination impractical)				
Method of disposal						Gravity			Pumped				
ALL INSTALLATIONS													
Record the following		At max rate:		CO ppm		CO ₂ %		CO/CO ₂		Ratio			
		At min rate (where possible)		CO ppm		CO ₂ %		CO/CO ₂		Ratio			
Where possible, has a flue integrity check been undertaken in accordance with manufacturers' instructions, and readings are correct?											Yes		
The operation of the boiler and system controls have been demonstrated to and understood by the customer											Yes		
The manufacturers' literature, including Benchmark Checklist and Service Record, has been explained and left with the customer											Yes		
Commissioning Engineer's signature													
Customer's signature (To confirm satisfactory demonstration and receipt of manufacturers' literature)													

* All installations in England and Wales must be notified to Local Authority Building Control (LABC) either directly or through a Competent Persons Scheme. A Building Regulations Compliance Certificate will then be issued to the customer.



12.9 Inspection and maintenance checklist

Inspection and maintenance checklist		Year 1	Year 2	Year 3	Year 4	Year 5	Year 6	Year 7	Year 8	Year 9	Year 10	Year 11	Year 12	Year 13	Year 14	Year 15
	Date:															
1	Check appliance operation (CH & DHW) and fault history	Yes <input type="checkbox"/>	Yes <input type="checkbox"/>	Yes <input type="checkbox"/>	Yes <input type="checkbox"/>	Yes <input type="checkbox"/>	Yes <input type="checkbox"/>	Yes <input type="checkbox"/>	Yes <input type="checkbox"/>	Yes <input type="checkbox"/>	Yes <input type="checkbox"/>	Yes <input type="checkbox"/>	Yes <input type="checkbox"/>	Yes <input type="checkbox"/>	Yes <input type="checkbox"/>	Yes <input type="checkbox"/>
2	Visual Inspection:- Check compliance of appliance, system and components	Yes <input type="checkbox"/>	Yes <input type="checkbox"/>	Yes <input type="checkbox"/>	Yes <input type="checkbox"/>	Yes <input type="checkbox"/>	Yes <input type="checkbox"/>	Yes <input type="checkbox"/>	Yes <input type="checkbox"/>	Yes <input type="checkbox"/>	Yes <input type="checkbox"/>	Yes <input type="checkbox"/>	Yes <input type="checkbox"/>	Yes <input type="checkbox"/>	Yes <input type="checkbox"/>	Yes <input type="checkbox"/>
3	Internal visual inspection Check for signs of leaking, corrosion and distress	Yes <input type="checkbox"/>	Yes <input type="checkbox"/>	Yes <input type="checkbox"/>	Yes <input type="checkbox"/>	Yes <input type="checkbox"/>	Yes <input type="checkbox"/>	Yes <input type="checkbox"/>	Yes <input type="checkbox"/>	Yes <input type="checkbox"/>	Yes <input type="checkbox"/>	Yes <input type="checkbox"/>	Yes <input type="checkbox"/>	Yes <input type="checkbox"/>	Yes <input type="checkbox"/>	Yes <input type="checkbox"/>
4	Appliance performance checks:															
4.1	Check Fan pressure test was cleaning required?	Yes <input type="checkbox"/>	Yes <input type="checkbox"/>	Yes <input type="checkbox"/>	Yes <input type="checkbox"/>	Yes <input type="checkbox"/>	Yes <input type="checkbox"/>	Yes <input type="checkbox"/>	Yes <input type="checkbox"/>	Yes <input type="checkbox"/>	Yes <input type="checkbox"/>	Yes <input type="checkbox"/>	Yes <input type="checkbox"/>	Yes <input type="checkbox"/>	Yes <input type="checkbox"/>	Yes <input type="checkbox"/>
		No <input type="checkbox"/>	No <input type="checkbox"/>	No <input type="checkbox"/>	No <input type="checkbox"/>	No <input type="checkbox"/>	No <input type="checkbox"/>	No <input type="checkbox"/>	No <input type="checkbox"/>	No <input type="checkbox"/>	No <input type="checkbox"/>	No <input type="checkbox"/>	No <input type="checkbox"/>	No <input type="checkbox"/>	No <input type="checkbox"/>	No <input type="checkbox"/>
		Yes <input type="checkbox"/>	Yes <input type="checkbox"/>	Yes <input type="checkbox"/>	Yes <input type="checkbox"/>	Yes <input type="checkbox"/>	Yes <input type="checkbox"/>	Yes <input type="checkbox"/>	Yes <input type="checkbox"/>	Yes <input type="checkbox"/>	Yes <input type="checkbox"/>	Yes <input type="checkbox"/>	Yes <input type="checkbox"/>	Yes <input type="checkbox"/>	Yes <input type="checkbox"/>	Yes <input type="checkbox"/>
4.2	Check and clean syphon	Yes <input type="checkbox"/>	Yes <input type="checkbox"/>	Yes <input type="checkbox"/>	Yes <input type="checkbox"/>	Yes <input type="checkbox"/>	Yes <input type="checkbox"/>	Yes <input type="checkbox"/>	Yes <input type="checkbox"/>	Yes <input type="checkbox"/>	Yes <input type="checkbox"/>	Yes <input type="checkbox"/>	Yes <input type="checkbox"/>	Yes <input type="checkbox"/>	Yes <input type="checkbox"/>	Yes <input type="checkbox"/>
4.3	Correct working gas inlet pressure	Yes <input type="checkbox"/>	Yes <input type="checkbox"/>	Yes <input type="checkbox"/>	Yes <input type="checkbox"/>	Yes <input type="checkbox"/>	Yes <input type="checkbox"/>	Yes <input type="checkbox"/>	Yes <input type="checkbox"/>	Yes <input type="checkbox"/>	Yes <input type="checkbox"/>	Yes <input type="checkbox"/>	Yes <input type="checkbox"/>	Yes <input type="checkbox"/>	Yes <input type="checkbox"/>	Yes <input type="checkbox"/>
4.4	Fue gas analysis Check combustion settings: Min/Max test modes	Yes <input type="checkbox"/>	Yes <input type="checkbox"/>	Yes <input type="checkbox"/>	Yes <input type="checkbox"/>	Yes <input type="checkbox"/>	Yes <input type="checkbox"/>	Yes <input type="checkbox"/>	Yes <input type="checkbox"/>	Yes <input type="checkbox"/>	Yes <input type="checkbox"/>	Yes <input type="checkbox"/>	Yes <input type="checkbox"/>	Yes <input type="checkbox"/>	Yes <input type="checkbox"/>	Yes <input type="checkbox"/>
4.5	Gas rate appliance at maximum output in test mode	Yes <input type="checkbox"/>	Yes <input type="checkbox"/>	Yes <input type="checkbox"/>	Yes <input type="checkbox"/>	Yes <input type="checkbox"/>	Yes <input type="checkbox"/>	Yes <input type="checkbox"/>	Yes <input type="checkbox"/>	Yes <input type="checkbox"/>	Yes <input type="checkbox"/>	Yes <input type="checkbox"/>	Yes <input type="checkbox"/>	Yes <input type="checkbox"/>	Yes <input type="checkbox"/>	Yes <input type="checkbox"/>
4.6	Check flame failure appliance	Yes <input type="checkbox"/>	Yes <input type="checkbox"/>	Yes <input type="checkbox"/>	Yes <input type="checkbox"/>	Yes <input type="checkbox"/>	Yes <input type="checkbox"/>	Yes <input type="checkbox"/>	Yes <input type="checkbox"/>	Yes <input type="checkbox"/>	Yes <input type="checkbox"/>	Yes <input type="checkbox"/>	Yes <input type="checkbox"/>	Yes <input type="checkbox"/>	Yes <input type="checkbox"/>	Yes <input type="checkbox"/>
4.7	Fit casing	Yes <input type="checkbox"/>	Yes <input type="checkbox"/>	Yes <input type="checkbox"/>	Yes <input type="checkbox"/>	Yes <input type="checkbox"/>	Yes <input type="checkbox"/>	Yes <input type="checkbox"/>	Yes <input type="checkbox"/>	Yes <input type="checkbox"/>	Yes <input type="checkbox"/>	Yes <input type="checkbox"/>	Yes <input type="checkbox"/>	Yes <input type="checkbox"/>	Yes <input type="checkbox"/>	Yes <input type="checkbox"/>
4.8	Check flue integrity	Yes <input type="checkbox"/>	Yes <input type="checkbox"/>	Yes <input type="checkbox"/>	Yes <input type="checkbox"/>	Yes <input type="checkbox"/>	Yes <input type="checkbox"/>	Yes <input type="checkbox"/>	Yes <input type="checkbox"/>	Yes <input type="checkbox"/>	Yes <input type="checkbox"/>	Yes <input type="checkbox"/>	Yes <input type="checkbox"/>	Yes <input type="checkbox"/>	Yes <input type="checkbox"/>	Yes <input type="checkbox"/>
6	Gas Safe/Benchmark documentation updated	Yes <input type="checkbox"/>	Yes <input type="checkbox"/>	Yes <input type="checkbox"/>	Yes <input type="checkbox"/>	Yes <input type="checkbox"/>	Yes <input type="checkbox"/>	Yes <input type="checkbox"/>	Yes <input type="checkbox"/>	Yes <input type="checkbox"/>	Yes <input type="checkbox"/>	Yes <input type="checkbox"/>	Yes <input type="checkbox"/>	Yes <input type="checkbox"/>	Yes <input type="checkbox"/>	Yes <input type="checkbox"/>
8	Appliance left to customer settings	Yes <input type="checkbox"/>	Yes <input type="checkbox"/>	Yes <input type="checkbox"/>	Yes <input type="checkbox"/>	Yes <input type="checkbox"/>	Yes <input type="checkbox"/>	Yes <input type="checkbox"/>	Yes <input type="checkbox"/>	Yes <input type="checkbox"/>	Yes <input type="checkbox"/>	Yes <input type="checkbox"/>	Yes <input type="checkbox"/>	Yes <input type="checkbox"/>	Yes <input type="checkbox"/>	Yes <input type="checkbox"/>
9	Gas Safe registration number	Yes <input type="checkbox"/>	Yes <input type="checkbox"/>	Yes <input type="checkbox"/>	Yes <input type="checkbox"/>	Yes <input type="checkbox"/>	Yes <input type="checkbox"/>	Yes <input type="checkbox"/>	Yes <input type="checkbox"/>	Yes <input type="checkbox"/>	Yes <input type="checkbox"/>	Yes <input type="checkbox"/>	Yes <input type="checkbox"/>	Yes <input type="checkbox"/>	Yes <input type="checkbox"/>	Yes <input type="checkbox"/>
	Gas Safe Engineers Signature															

Table 41 Inspection and maintenance checklist

SERVICE & INTERIM BOILER WORK RECORD

It is recommended that your boiler and heating system are regularly serviced and maintained, in line with manufacturers' instructions, and that the appropriate service / interim work record is completed.

Service provider

When completing a service record (as below), please ensure you have carried out the service as described in the manufacturers' instructions. Always use the manufacturers' specified spare parts.

SERVICE/INTERIM WORK ON BOILER <small>delete as appropriate</small>					Date:	
Engineer name:		Company name:				
Telephone N°:		Gas Safe registration N°:				
Max rate	CO	ppm	CO ₂	%	CO/CO ₂	
Min rate	CO	ppm	CO ₂	%	CO/CO ₂	
Where possible, has a flue integrity check been undertaken in accordance with manufacturers' instructions, and readings are correct?"					yes	
Gas rate:	m ³ /h	OR	ft ³ /h			
Were parts fitted? <small>delete as appropriate</small>	Yes	No				
Parts fitted:						
System inhibitor concentration has been checked and appropriate action taken, in accordance with BS 7593 and boiler manufacturers' instructions. *					yes	n/a
Comments:						
Signature:						

*A System inhibitor efficacy test is required on every annual service in accordance with the manufacturers' instructions and BS 7593. It is only acceptable to not have undertaken this if the service engineers attendance visit was in between annual services to attend a non-water facing component.

SERVICE/INTERIM WORK ON BOILER <small>delete as appropriate</small>					Date:	
Engineer name:		Company name:				
Telephone N°:		Gas Safe registration N°:				
Max rate	CO	ppm	CO ₂	%	CO/CO ₂	
Min rate	CO	ppm	CO ₂	%	CO/CO ₂	
Where possible, has a flue integrity check been undertaken in accordance with manufacturers' instructions, and readings are correct?"					yes	
Gas rate:	m ³ /h	OR	ft ³ /h			
Were parts fitted? <small>delete as appropriate</small>	Yes	No				
Parts fitted:						
System inhibitor concentration has been checked and appropriate action taken, in accordance with BS 7593 and boiler manufacturers' instructions. *					yes	n/a
Comments:						
Signature:						

*A System inhibitor efficacy test is required on every annual service in accordance with the manufacturers' instructions and BS 7593. It is only acceptable to not have undertaken this if the service engineers attendance visit was in between annual services to attend a non-water facing component.

SERVICE/INTERIM WORK ON BOILER <small>delete as appropriate</small>					Date:	
Engineer name:		Company name:				
Telephone N°:		Gas Safe registration N°:				
Max rate	CO	ppm	CO ₂	%	CO/CO ₂	
Min rate	CO	ppm	CO ₂	%	CO/CO ₂	
Where possible, has a flue integrity check been undertaken in accordance with manufacturers' instructions, and readings are correct?"					yes	
Gas rate:	m ³ /h	OR	ft ³ /h			
Were parts fitted? <small>delete as appropriate</small>	Yes	No				
Parts fitted:						
System inhibitor concentration has been checked and appropriate action taken, in accordance with BS 7593 and boiler manufacturers' instructions. *					yes	n/a
Comments:						
Signature:						

*A System inhibitor efficacy test is required on every annual service in accordance with the manufacturers' instructions and BS 7593. It is only acceptable to not have undertaken this if the service engineers attendance visit was in between annual services to attend a non-water facing component.

SERVICE/INTERIM WORK ON BOILER <small>delete as appropriate</small>					Date:	
Engineer name:		Company name:				
Telephone N°:		Gas Safe registration N°:				
Max rate	CO	ppm	CO ₂	%	CO/CO ₂	
Min rate	CO	ppm	CO ₂	%	CO/CO ₂	
Where possible, has a flue integrity check been undertaken in accordance with manufacturers' instructions, and readings are correct?"					yes	
Gas rate:	m ³ /h	OR	ft ³ /h			
Were parts fitted? <small>delete as appropriate</small>	Yes	No				
Parts fitted:						
System inhibitor concentration has been checked and appropriate action taken, in accordance with BS 7593 and boiler manufacturers' instructions. *					yes	n/a
Comments:						
Signature:						

*A System inhibitor efficacy test is required on every annual service in accordance with the manufacturers' instructions and BS 7593. It is only acceptable to not have undertaken this if the service engineers attendance visit was in between annual services to attend a non-water facing component.

SERVICE/INTERIM WORK ON BOILER <small>delete as appropriate</small>					Date:	
Engineer name:		Company name:				
Telephone N°:		Gas Safe registration N°:				
Max rate	CO	ppm	CO ₂	%	CO/CO ₂	
Min rate	CO	ppm	CO ₂	%	CO/CO ₂	
Where possible, has a flue integrity check been undertaken in accordance with manufacturers' instructions, and readings are correct?"					yes	
Gas rate:	m ³ /h	OR	ft ³ /h			
Were parts fitted? <small>delete as appropriate</small>	Yes	No				
Parts fitted:						
System inhibitor concentration has been checked and appropriate action taken, in accordance with BS 7593 and boiler manufacturers' instructions. *					yes	n/a
Comments:						
Signature:						

*A System inhibitor efficacy test is required on every annual service in accordance with the manufacturers' instructions and BS 7593. It is only acceptable to not have undertaken this if the service engineers attendance visit was in between annual services to attend a non-water facing component.

SERVICE/INTERIM WORK ON BOILER <small>delete as appropriate</small>					Date:	
Engineer name:		Company name:				
Telephone N°:		Gas Safe registration N°:				
Max rate	CO	ppm	CO ₂	%	CO/CO ₂	
Min rate	CO	ppm	CO ₂	%	CO/CO ₂	
Where possible, has a flue integrity check been undertaken in accordance with manufacturers' instructions, and readings are correct?"					yes	
Gas rate:	m ³ /h	OR	ft ³ /h			
Were parts fitted? <small>delete as appropriate</small>	Yes	No				
Parts fitted:						
System inhibitor concentration has been checked and appropriate action taken, in accordance with BS 7593 and boiler manufacturers' instructions. *					yes	n/a
Comments:						
Signature:						

*A System inhibitor efficacy test is required on every annual service in accordance with the manufacturers' instructions and BS 7593. It is only acceptable to not have undertaken this if the service engineers attendance visit was in between annual services to attend a non-water facing component.

* All installations in England and Wales must be notified to Local Authority Building Control (LABC) either directly or through a Competent Persons Scheme. A Building Regulations Compliance Certificate will then be issued to the customer.

SERVICE & INTERIM BOILER WORK RECORD

It is recommended that your boiler and heating system are regularly serviced and maintained, in line with manufacturers' instructions, and that the appropriate service / interim work record is completed.

Service provider

When completing a service record (as below), please ensure you have carried out the service as described in the manufacturers' instructions. Always use the manufacturers' specified spare parts.

SERVICE/INTERIM WORK ON BOILER <small>delete as appropriate</small>					Date:	
Engineer name:		Company name:				
Telephone N°:		Gas Safe registration N°:				
Max rate	CO	ppm	CO ₂	%	CO/CO ₂	
Min rate	CO	ppm	CO ₂	%	CO/CO ₂	
Where possible, has a flue integrity check been undertaken in accordance with manufacturers' instructions, and readings are correct?"					yes	
Gas rate:	m ³ /h	OR	ft ³ /h			
Were parts fitted? <small>delete as appropriate</small>	Yes		No			
Parts fitted:						
System inhibitor concentration has been checked and appropriate action taken, in accordance with BS 7593 and boiler manufacturers' instructions. *					yes	n/a
Comments:						
Signature:						

*A System inhibitor efficacy test is required on every annual service in accordance with the manufacturers' instructions and BS 7593. It is only acceptable to not have undertaken this if the service engineers attendance visit was in between annual services to attend a non-water facing component.

SERVICE/INTERIM WORK ON BOILER <small>delete as appropriate</small>					Date:	
Engineer name:		Company name:				
Telephone N°:		Gas Safe registration N°:				
Max rate	CO	ppm	CO ₂	%	CO/CO ₂	
Min rate	CO	ppm	CO ₂	%	CO/CO ₂	
Where possible, has a flue integrity check been undertaken in accordance with manufacturers' instructions, and readings are correct?"					yes	
Gas rate:	m ³ /h	OR	ft ³ /h			
Were parts fitted? <small>delete as appropriate</small>	Yes		No			
Parts fitted:						
System inhibitor concentration has been checked and appropriate action taken, in accordance with BS 7593 and boiler manufacturers' instructions. *					yes	n/a
Comments:						
Signature:						

*A System inhibitor efficacy test is required on every annual service in accordance with the manufacturers' instructions and BS 7593. It is only acceptable to not have undertaken this if the service engineers attendance visit was in between annual services to attend a non-water facing component.

SERVICE/INTERIM WORK ON BOILER <small>delete as appropriate</small>					Date:	
Engineer name:		Company name:				
Telephone N°:		Gas Safe registration N°:				
Max rate	CO	ppm	CO ₂	%	CO/CO ₂	
Min rate	CO	ppm	CO ₂	%	CO/CO ₂	
Where possible, has a flue integrity check been undertaken in accordance with manufacturers' instructions, and readings are correct?"					yes	
Gas rate:	m ³ /h	OR	ft ³ /h			
Were parts fitted? <small>delete as appropriate</small>	Yes		No			
Parts fitted:						
System inhibitor concentration has been checked and appropriate action taken, in accordance with BS 7593 and boiler manufacturers' instructions. *					yes	n/a
Comments:						
Signature:						

*A System inhibitor efficacy test is required on every annual service in accordance with the manufacturers' instructions and BS 7593. It is only acceptable to not have undertaken this if the service engineers attendance visit was in between annual services to attend a non-water facing component.

SERVICE/INTERIM WORK ON BOILER <small>delete as appropriate</small>					Date:	
Engineer name:		Company name:				
Telephone N°:		Gas Safe registration N°:				
Max rate	CO	ppm	CO ₂	%	CO/CO ₂	
Min rate	CO	ppm	CO ₂	%	CO/CO ₂	
Where possible, has a flue integrity check been undertaken in accordance with manufacturers' instructions, and readings are correct?"					yes	
Gas rate:	m ³ /h	OR	ft ³ /h			
Were parts fitted? <small>delete as appropriate</small>	Yes		No			
Parts fitted:						
System inhibitor concentration has been checked and appropriate action taken, in accordance with BS 7593 and boiler manufacturers' instructions. *					yes	n/a
Comments:						
Signature:						

*A System inhibitor efficacy test is required on every annual service in accordance with the manufacturers' instructions and BS 7593. It is only acceptable to not have undertaken this if the service engineers attendance visit was in between annual services to attend a non-water facing component.

SERVICE/INTERIM WORK ON BOILER <small>delete as appropriate</small>					Date:	
Engineer name:		Company name:				
Telephone N°:		Gas Safe registration N°:				
Max rate	CO	ppm	CO ₂	%	CO/CO ₂	
Min rate	CO	ppm	CO ₂	%	CO/CO ₂	
Where possible, has a flue integrity check been undertaken in accordance with manufacturers' instructions, and readings are correct?"					yes	
Gas rate:	m ³ /h	OR	ft ³ /h			
Were parts fitted? <small>delete as appropriate</small>	Yes		No			
Parts fitted:						
System inhibitor concentration has been checked and appropriate action taken, in accordance with BS 7593 and boiler manufacturers' instructions. *					yes	n/a
Comments:						
Signature:						

*A System inhibitor efficacy test is required on every annual service in accordance with the manufacturers' instructions and BS 7593. It is only acceptable to not have undertaken this if the service engineers attendance visit was in between annual services to attend a non-water facing component.

SERVICE/INTERIM WORK ON BOILER <small>delete as appropriate</small>					Date:	
Engineer name:		Company name:				
Telephone N°:		Gas Safe registration N°:				
Max rate	CO	ppm	CO ₂	%	CO/CO ₂	
Min rate	CO	ppm	CO ₂	%	CO/CO ₂	
Where possible, has a flue integrity check been undertaken in accordance with manufacturers' instructions, and readings are correct?"					yes	
Gas rate:	m ³ /h	OR	ft ³ /h			
Were parts fitted? <small>delete as appropriate</small>	Yes		No			
Parts fitted:						
System inhibitor concentration has been checked and appropriate action taken, in accordance with BS 7593 and boiler manufacturers' instructions. *					yes	n/a
Comments:						
Signature:						

*A System inhibitor efficacy test is required on every annual service in accordance with the manufacturers' instructions and BS 7593. It is only acceptable to not have undertaken this if the service engineers attendance visit was in between annual services to attend a non-water facing component.

* All installations in England and Wales must be notified to Local Authority Building Control (LABC) either directly or through a Competent Persons Scheme. A Building Regulations Compliance Certificate will then be issued to the customer.

TECHNICAL SUPPORT: 0330 123 3366
RENEWABLE SUPPORT: 0330 123 9229
CONTROLS AND CONNECTIVITY TEAM: 0330 123 3641
APPOINTMENTS: 0330 123 9339
SPARES: 0330 123 9779
LITERATURE: 0330 123 9119
TRAINING: 0330 123 0166
SALES: 0330 123 9669

Bosch Thermotechnology Ltd.
Cotswold Way, Warndon
Worcester WR4 9SW
United Kingdom
Tel. 0330 123 9559
worcester-bosch.co.uk

