

The **Greensource** air to air heat pump from Worcester

Technical and specification information

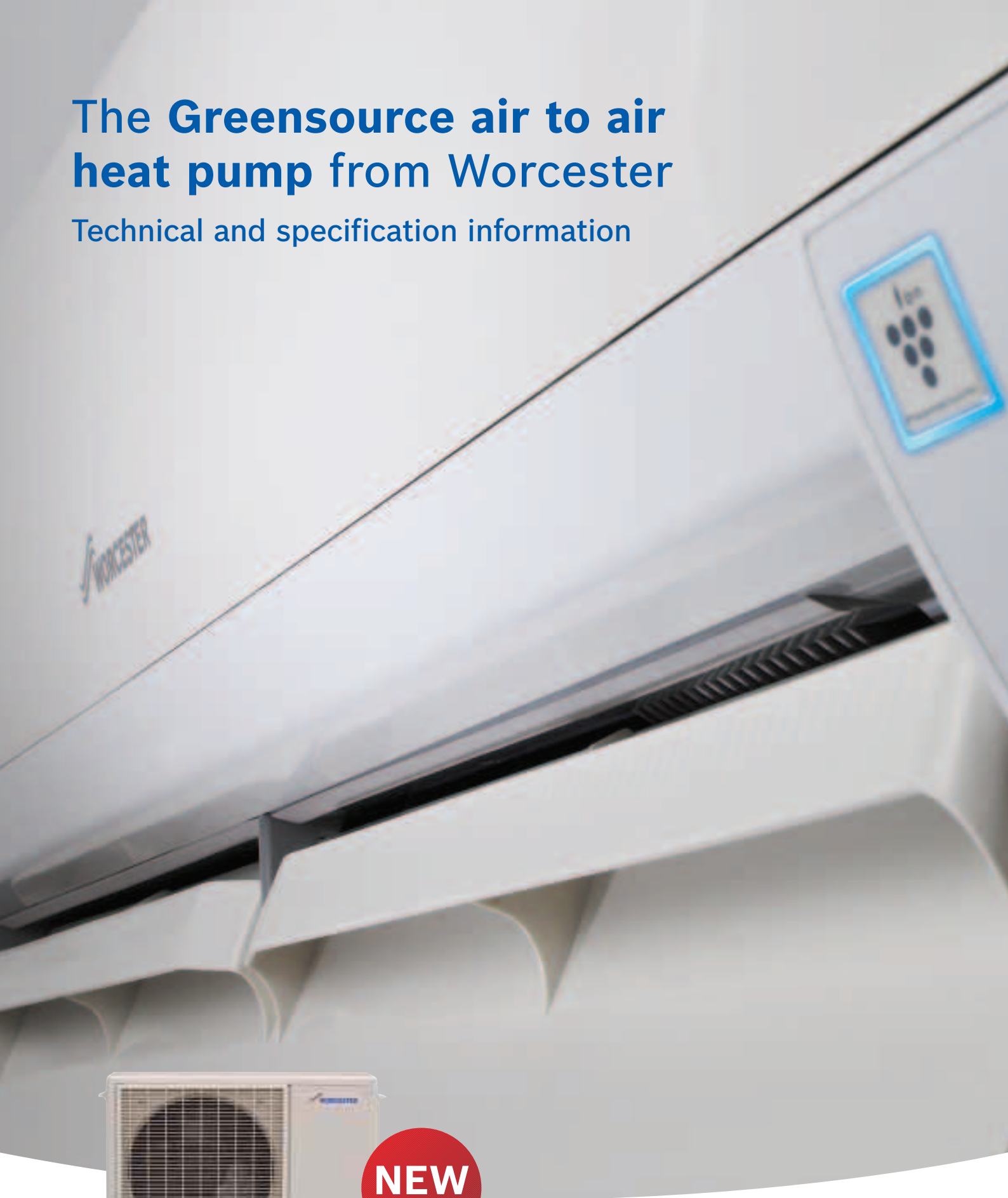

NEW
PRODUCT



 **WORCESTER**
Bosch Group



Worcester, Bosch Group headquarters

Worcester and you. Making a difference.

Working together for many years, heating professionals and Worcester have been making a real difference in hundreds of thousands of homes across the UK. We are recognised as a market leader in high efficiency, condensing boiler technology and are also committed to providing renewable energy solutions.

As part of the Bosch Group, our products are designed and manufactured to provide the high levels of quality and reliability which are synonymous with the Bosch name throughout the world.

We're a leading British company, employing approximately 2,000 people at our headquarters and manufacturing plants in Worcester and at Clay Cross in Derbyshire, including a nationwide network of over 300 Service Engineers and over 80 technically-trained Field Sales Managers.

As part of Europe's largest supplier of heating products, Worcester, Bosch Group has the UK-based resources and support capability to offer you the value-added solutions we feel you deserve.

"At Worcester we recognise the vital role you, our customer, has in the specification and installation of 'A' rated, energy efficient appliances in homes across the UK. We will continue to invest in our products, people, facilities and added value services such as training, to give you the support you require in providing a total solution for your customers' comfort."

Richard Soper,
Managing Director, Worcester, Bosch Group

Contents

	Page
The Greensource air to air heat pump	4 - 11
Technical data	6
The inside story	12 - 13
Guide to the installation of a Greensource air to air heat pump	14 - 17
Installation requirements	18 - 19
FAQs	22
Installation accessories	23
After-sales	25
Worcester training	26 - 27





The Greensource air to air heat pump

Advanced renewable energy technology from Worcester that's helping to point the way to a greener and more sustainable future.

As part of the Bosch group, Worcester is committed to environmental protection. Product development is prioritised in the interests of the safety of people, the economical use of resources and environmental sustainability.

In just a few short years, the nature and technology of Britain's domestic heating and hot water systems industry have changed dramatically. Faced with the harsh reality of all the facts, such change has been not only inevitable but crucial.

Recent statistics revealed that approximately 25% of the UK's carbon dioxide emissions were produced by home energy consumption, 75% of this is for the provision of heating and hot water.

In April 2005, the Building Regulations effectively decreed that high-efficiency, low-emissions condensing boilers were a significant first step in the massive challenges presented by global warming and climate change.

Since then words and expressions such as renewable energy, sustainable technology and carbon footprint have become part of everyday conversation and have been fuelled by extreme weather and stark television images of melting polar ice sheets.

Hence the many reasons why Worcester, Bosch Group has taken the lead in sourcing and developing heating and hot water solutions which reduce the impact on the environment – not only for today, but well into the future.

Principles of operation

An air to air heat pump is an all-in-one heating and cooling system that is designed to provide year-round comfort.

A Worcester Greensource air to air heat pump offers additional advantages such as relatively simple and cost-effective installation, suitability for a wide variety of property types and sizes and, at a time when fuel costs are rising, the chance to help your customers reduce their heating bills.

The appliance is dispatched complete with comprehensive installation, maintenance and user instructions.

Please note that this leaflet is a guide to installation only. For full details please refer to the installation and commissioning instructions. We recommend that you attend our training academy to gain the product knowledge of our Greensource air to air heat pump prior to installing. **It is a legal requirement for the connection of the refrigerant circuit to be carried out by a suitably qualified refrigeration engineer.** Please see page 26 for more information on training courses.

How a Greensource air to air heat pump distributes heat

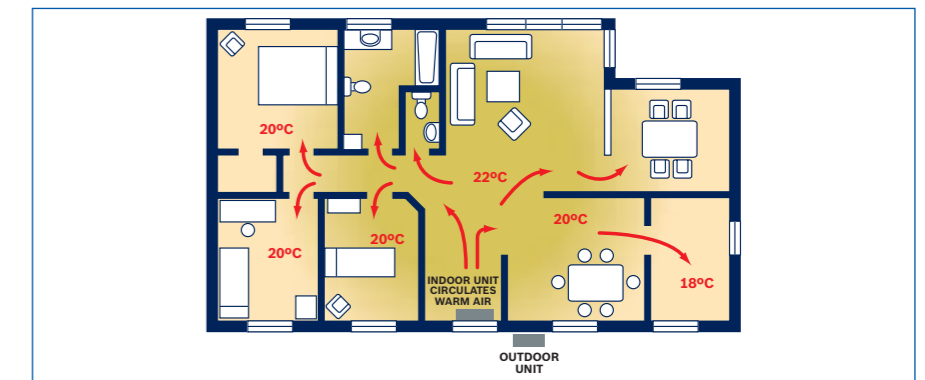
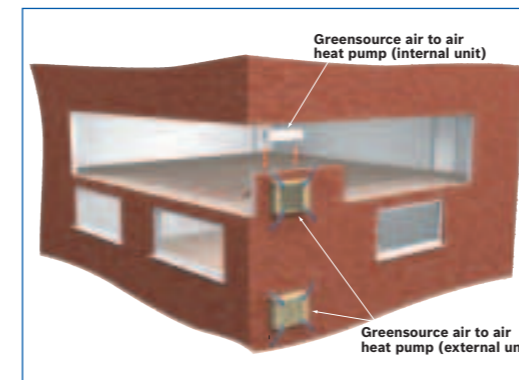

Heat is distributed evenly through the property

The Greensource air to air heat pump at a glance

Greensource air to air heat pump outdoor unit

	Greensource air to air heat pump outdoor unit
Dimensions w x h x d (mm)	780 x 540 x 265
Weight (kg)	39
Airflow (m ³ /min)	30.2
Sound level cooling (dB(A))	47
System refrigerant R410A (kg)	0.99
Digitally controlled rotary hermetically sealed compressor	Digitally controlled
Single phase voltage (V)	220-240
Maximum operating current (Amps)	8.7

Kit part number 7 716 150 011

Greensource air to air heat pump indoor unit

	Greensource air to air heat pump indoor unit
Dimensions w x h x d (mm)	860 x 292 x 205
Weight (kg)	9
Min/max emitted heat output (kW)	0.9/6.0
Min/max emitted cooling effect (kW)	0.9/4.0
Airflow (m ³ /min) – cooling	6.9 - 10.6
Sound level (dB(A)) low fan speed cooling	28
Single phase voltage (V)	220-240
Outdoor rating	IPX4
Maximum operating current (Amps)	8.7
CoP (EN 14511)	4.5

Output data applies at 7°C outdoors, wet bulb 20°C indoor temperature.

Features

- Energy efficient – CoP* of up to 5
- 'A' Rated for efficiency
- High efficiency in all temperature ranges
- Could heat an area up to 100m²
- Compact design requiring only a suitable outside wall
- Suitable for a wide variety of property types, including apartments, conservatories and small industrial units
- Quiet operation
- Easy to install and maintain
- Modulating fan saves up to 30-40% compared with fixed speed fan
- Inverter controlled unit
- Digitally controlled compressor saves up to 15% compared to fixed speed unit

*Coefficient of Performance - the basis of heat pump efficiency (see page 8).
 **Terms and conditions apply.

Note: It is a legal requirement for the connection of the refrigerant circuit to be carried out by a suitably qualified refrigeration engineer.

Features

- Can be used to provide cooling air in the summer
- Active Ion-technology air purification, ideal for allergy sufferers
- Auto defrost function
- Proven inverter technology that saves you money
- Optimum start feature for added comfort
- Uses non-ozone depleting refrigerant R410A
- 2 year** parts and labour warranty for peace of mind
- Twin rotary compressor – reduces noise and vibration
- Evaporation has larger enhanced surface area than normal AC units
- Electronic expansion valve



Technical data – Greensource air to air heat pump

Capacity heating (kW)	6
Inverter capacity range (kW)	900 - 6,000
CoP*	4.5
Dimensions w x h x d (mm)	– indoor unit 860 x 292 x 205 – outdoor unit 780 x 540 x 265
Weight (kg)	– indoor unit 9 – outdoor unit 39
Power supply	220 - 240 V 50Hz
Indoor fuse size (A)	10
Refrigerant	R410A
Amount of refrigerant (kg)	0.99
Capacity cooling (kW)	4
Inverter capacity range (kW)	900 - 4,000
Cooling EER	4.5
Energy rating	A
Indoor sound pressure level cooling (dB(A))	28
Outdoor sound pressure level cooling (dB(A))	47
Operating range (°C) – cooling	-10 - +43
– heating	-20 - +24
Digitally controlled rotary hermetically sealed compressor	Digitally controlled
Connection**	– liquid side 1/4" – gas side 3/8"
Drain pipe (mm)	18
Max refrigerant pipe length (m)	15
Pre-charged length (m)	10
Max. difference in height (m)	7

For every extra metre thereafter add	20g refrigerant per m
Mode	Cool/heat/dry/fan/auto
Fan speed	High/med/low/auto

Operational features (see page 11 for details)	
Full power operation	•
Time	24 hour programmer
Clock	•
Timer on timer	•
Timer off	•
Timer on/off	•
1 hour timer	•
Vertical swing	Auto
Horizontal swing	Auto
Dust filter	•
Anti-bacterial air purifying filter	•
Remote controller	•
Plasmacluster ION	•
10°C heating operation	•
Auto restart	•
Auto changeover	•
Winter cool function	•
Self-clean function	•
Coanda airflow	•
Auto-sleep function	•
Awakening function	•
Auto defrost	•

*CoP calculated using EN 14511

**Only refrigeration pipe must be used for connection

The Greensource air to air heat pump

Principles of operation – What is an air to air heat pump?

An air to air heat pump is an all-in-one heating and cooling system that's designed to provide year-round comfort.

Outside air, even on cold days, contains latent heat which can be converted to provide environmentally-friendly, low cost heating for a wide range of domestic and commercial properties. Using a similar principle to the refrigerator, but in reverse, the Greensource air to air heat pump's outdoor unit draws in and warms the outside air before transferring it into the property where it is circulated by an indoor fan unit. It is an extremely efficient process which could produce up to 5 times more heat than the electrical energy it uses and, as an added benefit, this operating process can be reversed in the warmer months to provide cooling air.

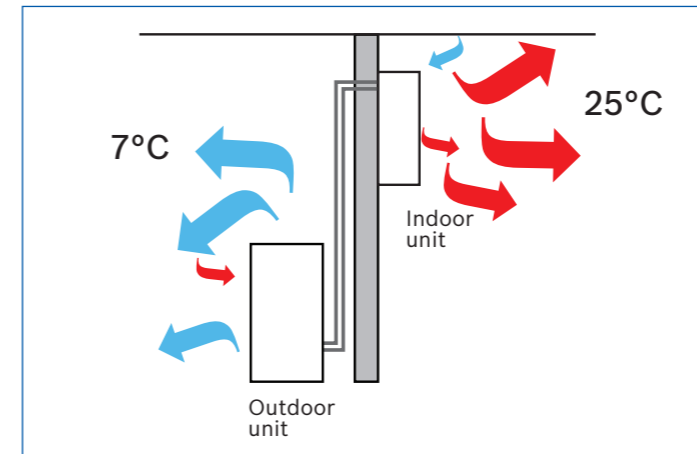

Typical temperatures in heating mode

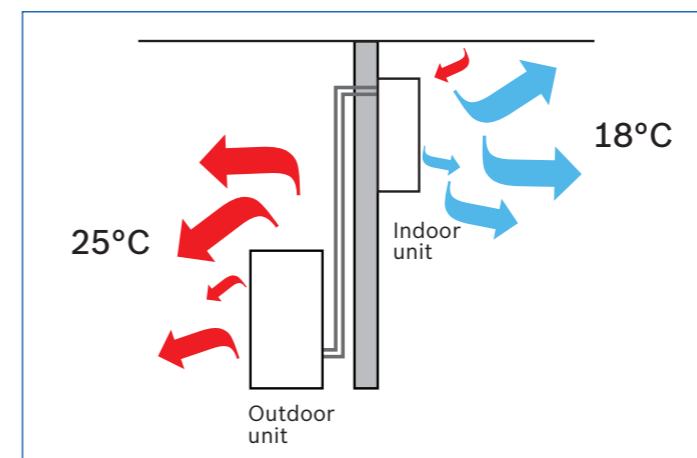

Typical temperatures in cooling mode

The Greensource air to air heat pump also incorporates Plasmacluster Ion-technology, a unique active air purification feature which neutralises airborne bacteria, viruses and allergens and is particularly beneficial to asthma and hay fever sufferers. This technology is also effective against odours such as tobacco smoke.

Due to the compact size of the outdoor unit – it requires only a suitable outside wall or solid base e.g. a paved area – a Greensource air to air heat pump is an attractive option as a supplementary heating source for a wide range of applications. These include smaller properties such as apartments, conservatories, holiday homes, offices, factory units and workshops etc.

In some circumstances an air to air heat pump can also be used as the primary heating source.

A Greensource air to air heat pump comprises two main components – an outdoor inverter unit and an indoor unit – and is controlled using a multi-function remote control.

High efficiency in all temperature ranges

The outdoor unit uses the latest inverter technology, which modulates the compressor speed according to demand to provide higher efficiency and lower running costs, combined with lower noise levels and a longer lifespan. It incorporates an electronic expansion valve for maximum performance. The Greensource air to air heat pump is 'A' rated for performance and has an energy efficiency rating (EER) of 3.5.

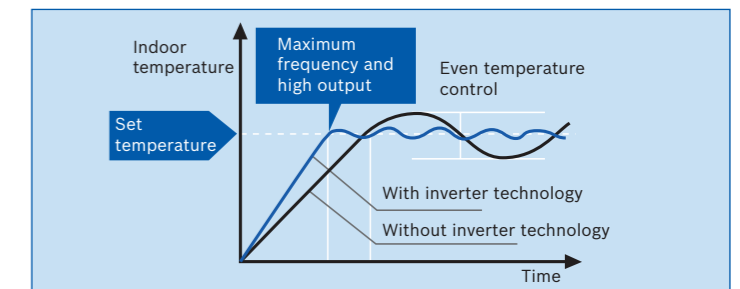

Inverter technology gives greater comfort and efficiency

In order to obtain the best CoP performance and efficiency we recommend you use either heating or cooling mode.

Coefficient of Performance

The performance and efficiency of an air source heat pump system is commonly measured by the Coefficient of Performance (CoP). The CoP is a simple calculation which works out how much energy the heat pump is able to extract from the energy source compared to the amount of electrical energy used by the heat pump.

$$\text{CoP} = \frac{\text{Heat output of system (useful heat)}}{\text{Electrical input from compressor and fan motors}}$$

E.g.:

$$\text{CoP of 5} = \frac{6\text{kW heat pump}}{1.2\text{kW of electrical input}}$$

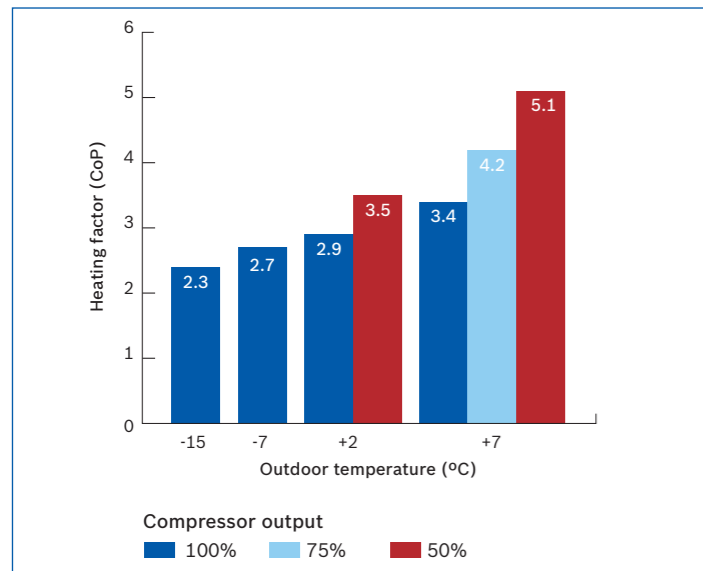

CoPs at different temperatures

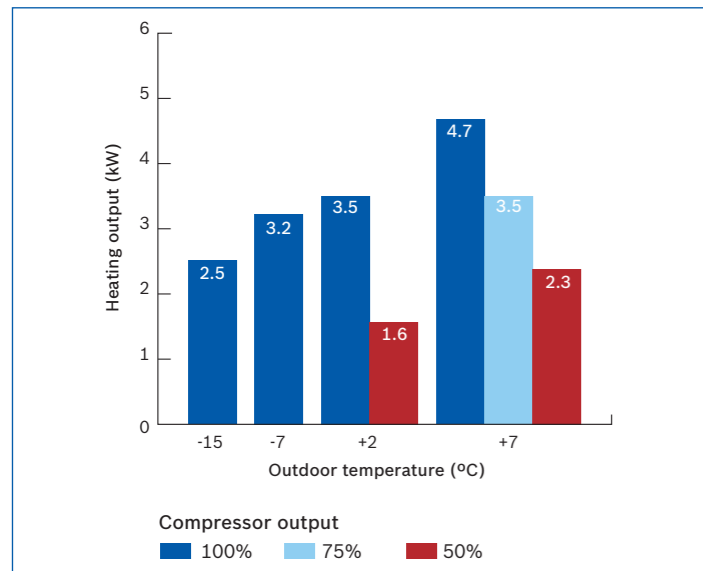

Emitted heating output

Energy Efficiency Rating (EER)

The EER is the efficiency rating of the unit within a particular range of external and internal temperatures. The EER is related to the CoP by converting the cooling capacity from watt W to Btu/hr. The higher the EER, the more efficient the heat pump is.

Plasmacluster Ion-technology



Plasmacluster Ion button

Plasmacluster Ion-technology is switched on by pressing the button shown left. The Greensource heat pump's unique active air purification system emulates nature's own air purification process. It emits positive and negative Plasmacluster ions (positive hydrogen ions and negative oxygen ions are surrounded by multiple water molecules to form a cluster, hence the description "cluster ions") that spread throughout the room to purify the air by attacking harmful airborne substances such as bacteria, viruses and allergens, including cigarette smoke. These ions are the same as those found in nature; they are completely safe.

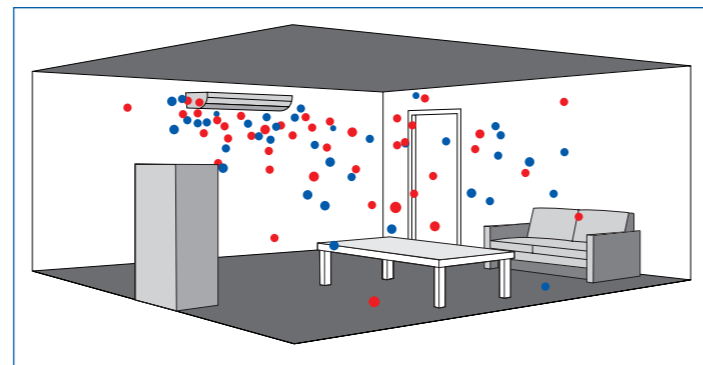

Active air purification creates positive and negative ions which breakdown air pollutants

The following tables show how effective Plasmacluster Ion-technology can be in suppressing mould, viruses and allergens, although this can vary depending upon the room layout in which the unit is operating. This has been tested and verified by a number of worldwide universities and test institutes.

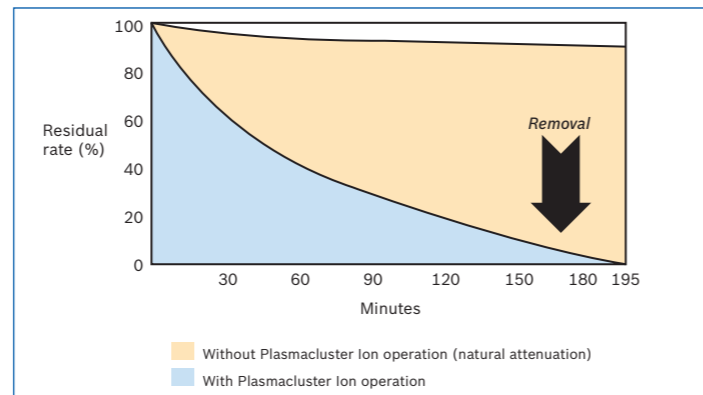

Suppression of airborne mould

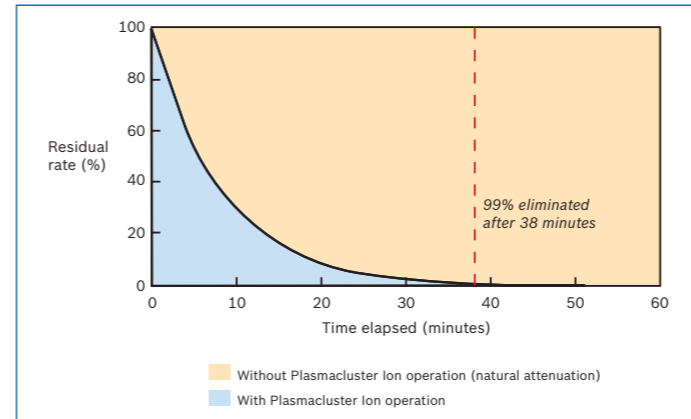

Surviving airborne bacteria

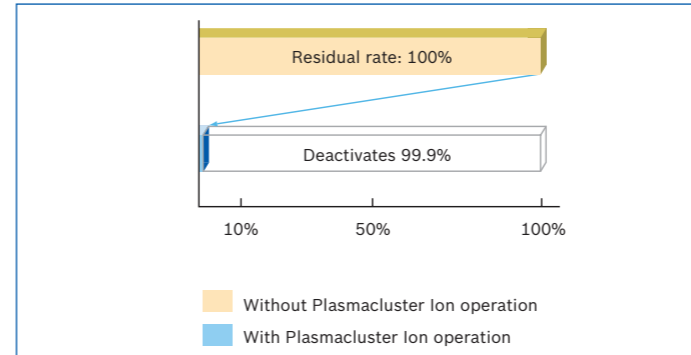

Suppression of airborne allergens

The effectiveness of positive and negative ions in destroying airborne viruses, allergens and mould has been tested and verified by numerous research bodies and institutions around the world.

Positive and negative Plasmacluster ions collect on the surface of the allergen where they react and become powerful hydroxyl radicals (OH).

These radicals take out the allergen's hydrogen atoms, destroying the proteins and preventing water formation.

Plasmacluster Ion-technology is also effective in reducing odours around the home as illustrated in the table below.

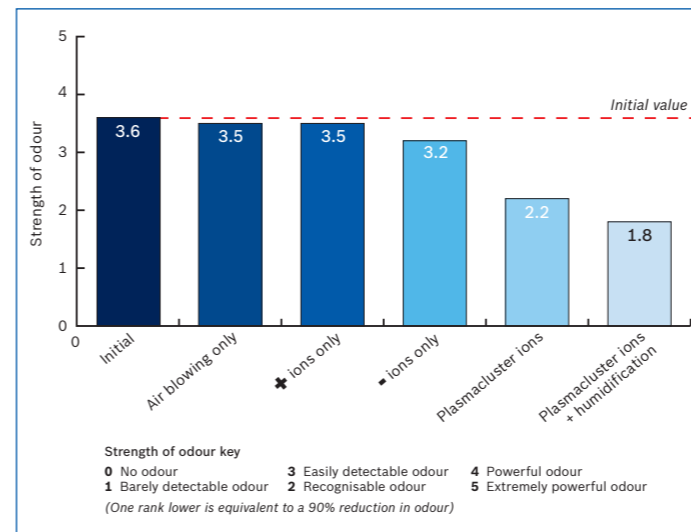

Deodourising performance against embedded cigarette odours



Plasmacluster Ion button

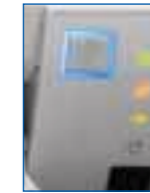

Indoor unit display

For the best air quality we recommend that the Plasmacluster Ion button is pressed and the blue light is visible.

Coanda airflow system for heating and cooling

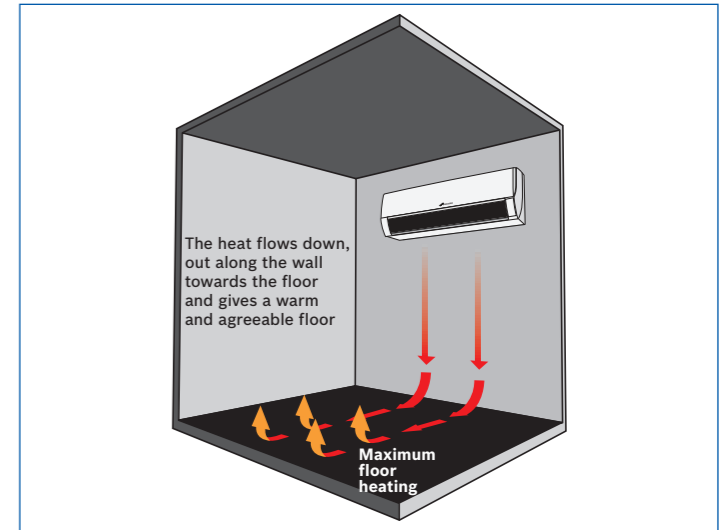

Warm air distribution in heating mode to prevent draughts

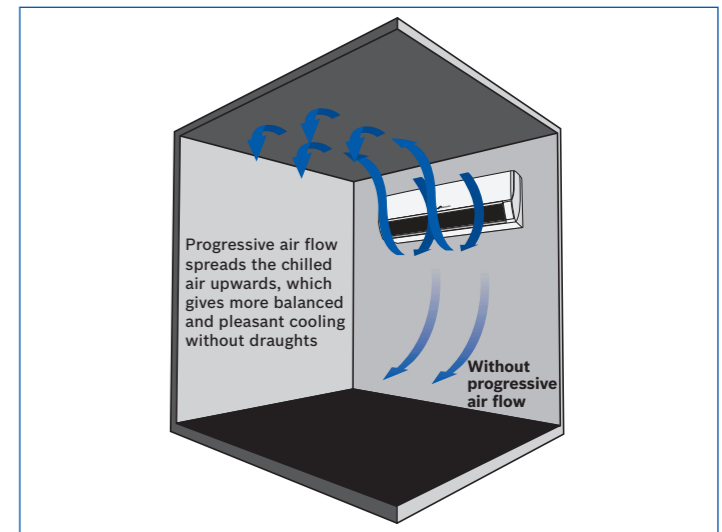

Cool air distribution in cooling mode



Coanda airflow system button

The Greensource indoor unit can be set to provide progressive airflow in both heating and cooling modes by pressing the button (shown left). When in the heating mode the airflow can be directed down the wall and across the floor, from where it rises to provide more evenly distributed heat. In cooling mode, the air can be directed upwards and across the ceiling from where it falls evenly without causing a draught.

The Greensource air to air heat pump also has a special +10°C maintenance heating function which is particularly useful for keeping a property protected from extremely cold weather when it is left empty for long periods e.g. holiday homes or when low heating costs are required e.g. for garages and workshops. This function is activated with a single press on the remote control.

An optimum start facility is available which automatically activates the heat pump prior to the set start time to ensure that the desired temperature is reached by the programmed time.

Control unit and symbols

The Greensource air to air heat pump is controlled by a remote control unit which has a multi-function menu.

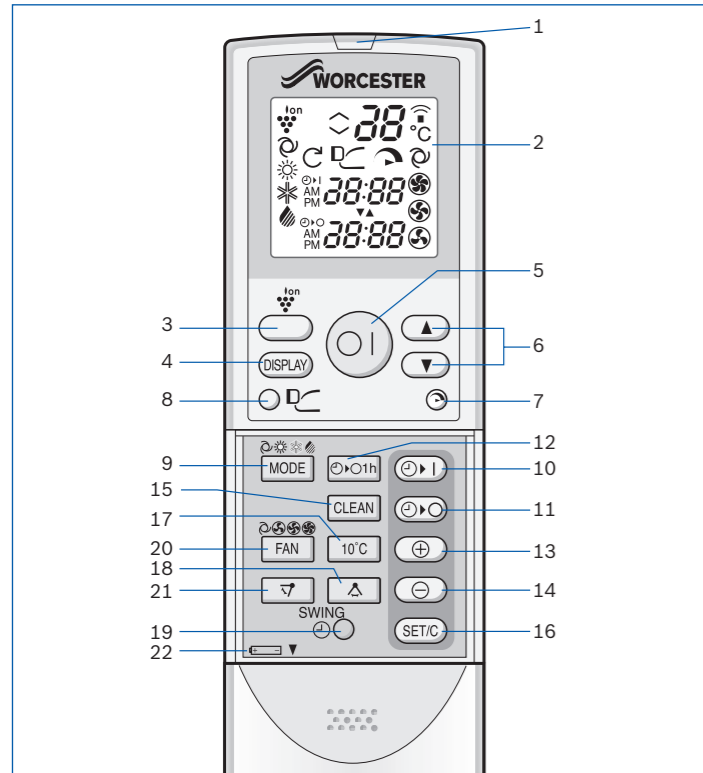

- | | |
|---|---|
| 1 Transmitter | 13 Timer advance button |
| 2 Display (LCD) | 14 Timer reverse button |
| 3 Plasmacluster button | 15 Self clean button (dries unit to prevent mould growth) |
| 4 Display button (no function) | 16 Timer set/cancel button |
| 5 On/off button | 17 10°C button (night set back) |
| 6 Thermostat buttons (1°C up or down on each press) | 18 Swing button (horizontal direction) |
| 7 Full power button (for 1 hour boost) | 19 Clock button |
| 8 Progressive airflow button (Coanda effect) | 20 Fan speed button (Auto (E), Soft (H), Low (G), High (F)) |
| 9 Mode button (Auto (A), Heating (B), Cooling (C), De-humidifier (D)) | 21 Swing button (vertical direction) |
| 10 Timer on button | 22 Indicates battery compartment is below this mark |
| 11 Timer off button | |
| 12 One-hour off timer button | |



Working temperature

Minimum working temperatures

The heat pump is designed to operate efficiently in heating mode at temperatures down to -20°C.

Greensource air to air components list

- 1 x outdoor unit
- 1 x indoor unit and wall mounting plate
- 2 x air filters
- 1 x remote control (including 4 AAA batteries)
- 1 x user guide
- 1 x installation manual and guarantee card

Part No. 7 716 150 011

Electrical isolation

Note: Both the indoor and outdoor units require a means of electrical isolation. It is recommended that the outdoor and indoor units are supplied with an earth leakage breaker in order to protect against electric shock in case of a leak.

Use the current-activated, high-sensitivity, high-speed type breaker with a rated sensitivity current of below 30mA and an operating time of below 0.1 second.

Wiring of the units must be in line with the latest edition of the IEE Wiring Regulations, also known as BS 7671: 2008.

Operating functions		
Operation		
	Inverter controlled operation	Quick cooling and heating operation, decreases fluctuation in temperature and reduces power consumption
	Full power mode	Heat pump works at maximum power to rapidly cool or heat room
	Turbo operation	Heat pump fan works at "extra-high" fan speed with a setting temperature of 15°C in COOL & DRY and 32°C in HEAT mode to rapidly cool or heat room
	Lower room temperature setting (from 18°C)	In cooling operation, room temperature can be set from 18°C
	Computerised dry mode operation*	Indoor fan motor and compressor are controlled by the microcomputer to maintain room humidity without dropping room temperature
	Auto operation mode*	In the AUTO mode, the temperature setting and mode are automatically selected according to room temperature
	Auto & 3-step fan speed settings	Auto fan speed and 3-step (HIGH/LOW/SOFT) manual fan speed are available
	Auto restart function	When power failure occurs and after power recovery, unit will automatically restart in same setting which was active before power failure
	Auto changeover*	During AUTO mode operation, the mode will automatically switch between HEAT and COOL mode to maintain a comfortable room temperature
	Winter cool function	Cooling operation is available during winter season down to -10°C outside temperature
Air quality		
	Plasmacluster ion	Plasmacluster ion generator inside indoor unit releases positive and negative Plasmacluster ions into room and reduces some airborne mould and viruses
	Anti-bacterial air purifying filter	Replaceable filter
	Anti-mould, detachable and washable air filter	Easily removed and cleaned by vacuuming
Airflow		
	Wide airflow	Provides much wider airflows to deliver Plasmacluster ions and cold or warm air to every corner of room
	Coanda airflow system	Provides warm air travelling down the wall to the floor during heating operation and cold air travelling up the ceiling during cooling operation to avoid direct airflow
	4-way auto air swing	Automatic vertical and horizontal airflow is available in order to make room uniformly cool or warm
	Auto swing louvre	Automatic vertical airflow is available in order to make the room uniformly cool or warm
Control convenience		
	Microcomputer control	Reliable and efficient operation
	LCD wireless remote control	
	24 hour ON/OFF programmable timer	The start or stop operation (hour and minute) can be set at same time
	1 hour OFF timer	When the ONE-HOUR OFF TIMER is set, the unit will automatically turn off after one hour
	"Awakening" function	When the ON timer is set, the unit will turn on prior to the set time to allow the room to reach the desired temperature by the programmed time
	"Auto sleep" function	When the OFF timer is set, the temperature setting is automatically adjusted to prevent the room from becoming excessively hot or cold while you sleep
Additional features		
	Quiet operation	Only 28Db(A) in soft fan speed mode
	Self cleaning function	Reduces growth of mould fungus, and dries the inside of the air conditioner unit with Plasmacluster ions used in cooling mode

*These modes do not give the best efficiency and savings, it is recommended either cooling or heating mode is used for optimum performance.

The Greensource air to air heat pump outdoor unit – inside story

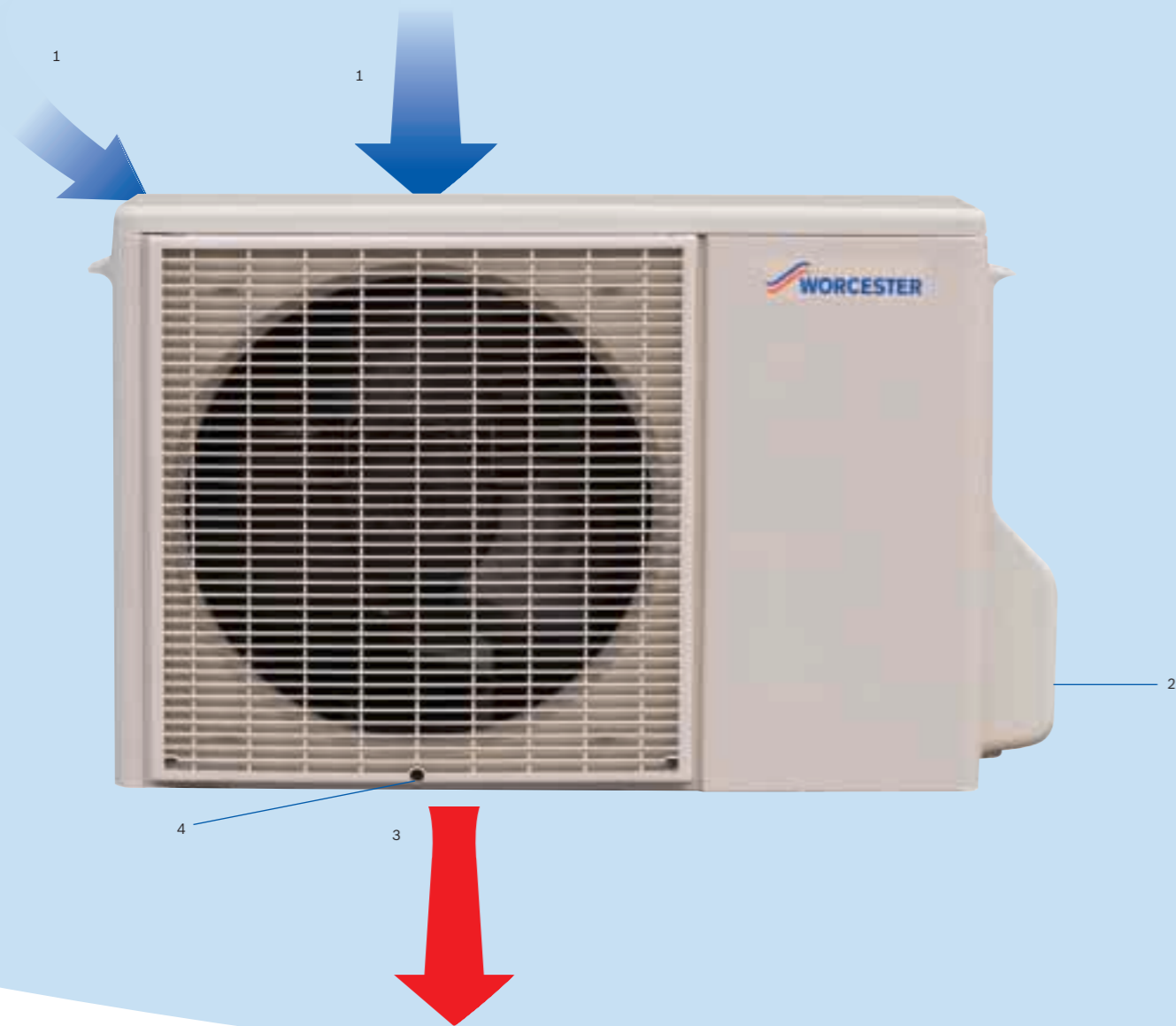

Key to components

- 1. Inlet (air) rear
- 2. Refrigerant tube and interconnecting cord
- 3. Outlet (air)
- 4. Drainage holes

The Greensource air to air heat pump indoor unit – inside story

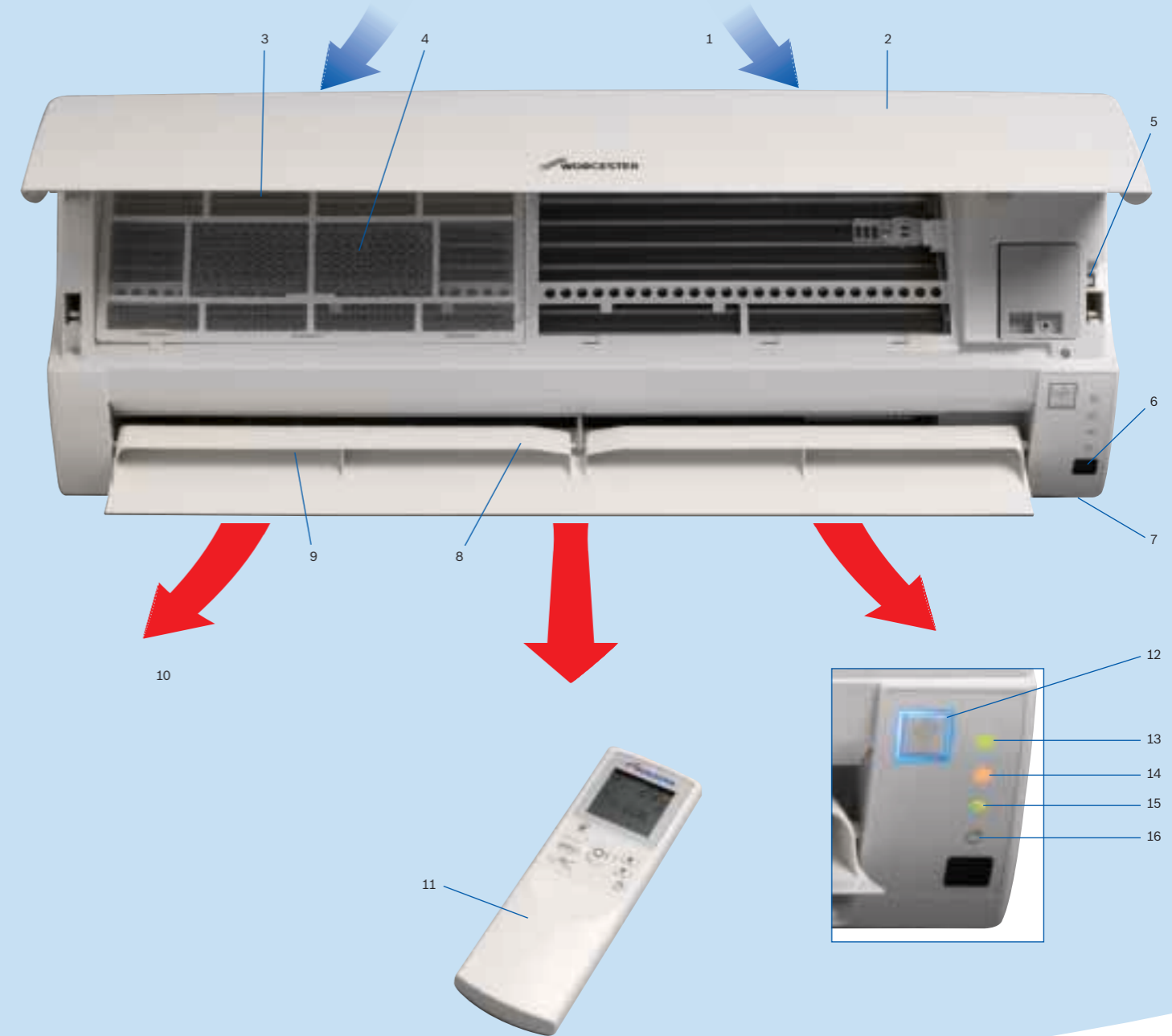

Key to components

- 1. Inlet (air) at top of unit
- 2. Open panel for access to filters
- 3. Air filter
- 4. Air purifying filter
- 5. AUX button
- 6. IR receiver window
- 7. Power supply cord (at rear of unit)
- 8. Vertical adjustment louvre

- 9. Horizontal adjustment louvre (behind vertical louvre)
- 10. Outlet (air)
- 11. Remote control
- 12. Plasmacluster lamp (blue)
- 13. Operation lamp (green)
- 14. Timer lamp (orange)
- 15. Full power lamp (green)
- 16. Self clean lamp (green)

Installing a Greensource air to air heat pump

Siting of the outdoor unit

The outdoor unit can be either wall mounted or floor standing. If floor standing, it should be placed on a flat, solid base e.g. concrete slabs or a suitable stand. A minimum clearance of 200mm is required around the unit to ensure that there is adequate airflow (ideally 2 million litres per hour) for the heat pump to operate at maximum performance. The outdoor connecting pipes should be suitably insulated with Class 'O' insulation to prevent freezing.

The heat pump can produce up to 20 litres of non-acidic condensation per day, depending on external temperatures, and this should be diverted to a mains drain or a soak away. In order to prevent freezing the condensate pipe must be insulated with Class 'O' insulation and the drainage pipe must slope towards a drain.

General siting advice

- If floor standing, the unit should be on a stable base or stand. Rubber matting can be used directly under the heat pump to act as a sound proofing material.
- Provide sufficient space around the unit for effective operation and ease of access for maintenance and cleaning.
- The unit should be sited where it will be sheltered from strong winds and rain. Also avoid locations where muddy water might be a problem (alongside a road, for example) or where it could be tampered with.
- Keep the air outlet free of any obstacles, or this could affect the performance and increase noise levels.
- Avoid placing the unit where hot airflow or noise could be nuisance to the property owner or neighbours.
- The condensate water pipe must always be installed and suitably insulated.

Installation clearances

Provide as much installation space as possible for efficient air movement. The following diagram shows the minimum requirements.

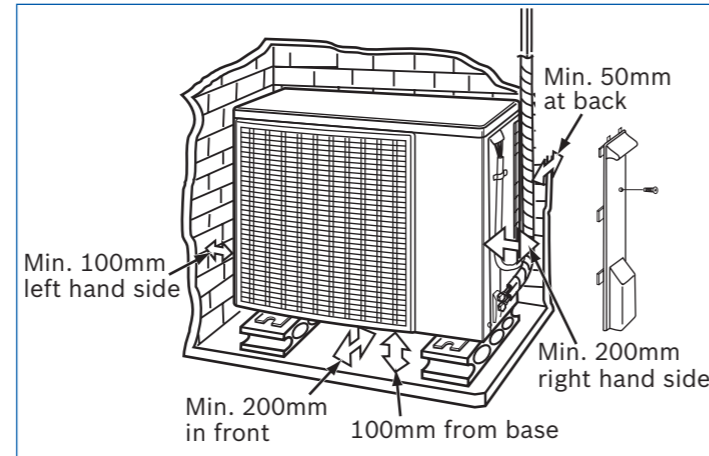

Outdoor unit clearances (mm)	
Minimum distance at rear	50
Minimum distance to the right	200
Minimum distance to the left	100
Minimum distance in front (installation)	200
Minimum distance in front (servicing)	600
Minimum distance above base	100

Outdoor unit casing dimensions

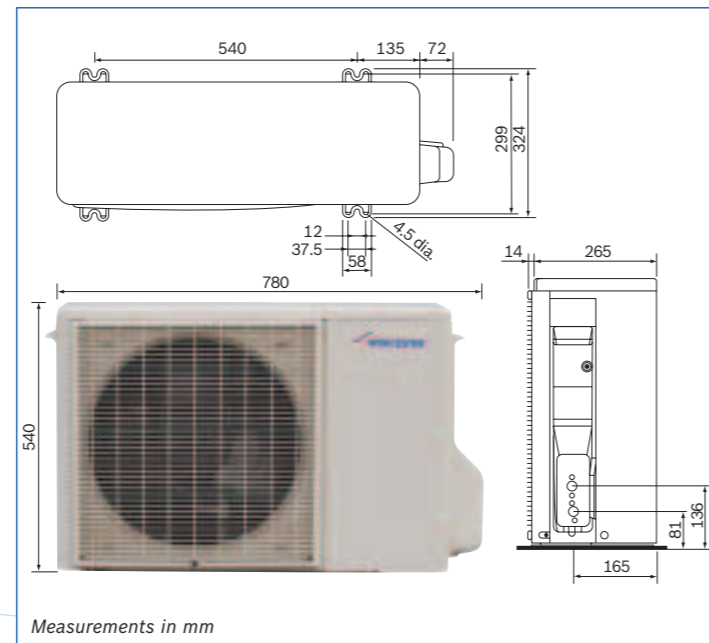

Measurements in mm

Siting of the indoor unit

The most important factor when selecting the position for the indoor unit is to optimise the heat dispersion. It is important to keep the air outlet clear of any obstacle which might prevent air flowing smoothly in the entire room.

General siting advice

- Avoid placing the unit on a wall next to a bedroom.
- Avoid placing the unit in any room where the airflow or vibration could be a nuisance.
- Consider the best way of connecting the refrigerant pipes between the indoor and outdoor units. Going straight through the wall is the best option as it avoids running pipework inside the property.
- Make sure there is sufficient space around the unit and that the air filters can be easily removed for cleaning and replacement.
- Locate the unit and the remote control at least 1 metre from a TV set, radio or similar electrical appliance to avoid possible interference with the operation of the control unit.
- Avoid locating the remote control in a room which has electronic simultaneous-start or rapid-start fluorescent lighting which may affect its operation.
- Wiring of the units must be in line with the latest edition of the IEE Wiring Regulations (currently the 17th edition in force since 1st July 2008) also known as BS 7671:2008.

Installation clearances

Provide as much installation space as possible for efficient operation of the units.

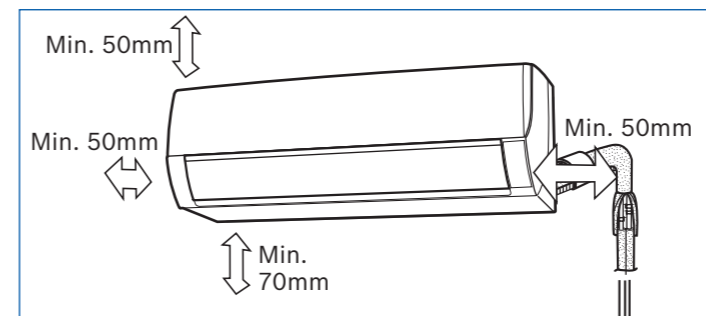

Indoor unit clearances (mm)	
Minimum distance above	50
Minimum distance to side	50
Minimum distance below	70

Indoor unit casing dimensions

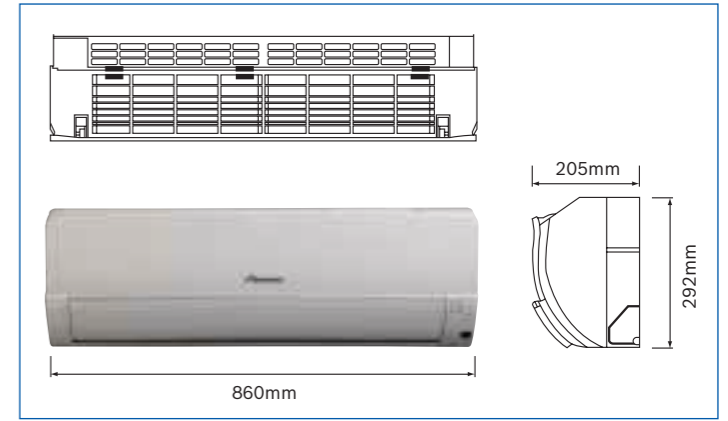

Pipework connections

Piping length between the outdoor and indoor units should be 1m or more in order to decrease vibration propagated from the outdoor unit.

The unit comes pre-charged with enough refrigerant for a pipe length of up to 10m. If the piping length exceeds 10m, 20g of refrigerant per 1m should be added by a qualified refrigeration engineer.

Only refrigerant grade copper pipe suitable for refrigerant R410A should be used.

When the outdoor unit is placed at a higher level than the indoor units, a trap should be provided near the hose's lead-in port. The trap is required to help store lubrication oil for the compressor operation when the units are at different heights.

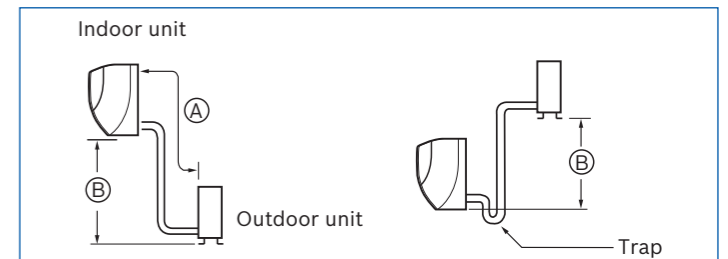

Piping length

Max. piping length (A) (m)	Max. level difference (B) (m)
15	7

Installing a Greensource air to air heat pump – a step by step guide



1. To begin, it is important to find a **suitable site** to mount the Greensource outdoor inverter unit. If choosing a floor siting situation, the system requires a stable base and should be sheltered from rain water and strong winds; not be exposed to muddy water (along a road for example) or in a position where the unit can be tampered with. It is also worth keeping in mind that the unit's location should be far enough away that outgoing air and operating noise won't annoy the homeowner or the neighbours. (Fig. 1)

A good tip to ensure a successful installation is to complete a log throughout the commissioning process; this will help remind you of all the steps that need to be completed.

2. Once happy with the chosen site, **position the outdoor unit** according to the installation instructions. The Greensource air source heat pump can be mounted onto a wall or directly onto the floor. Allow a 200mm clearance around the appliance to provide as much installation space as possible for efficient air movement. (Fig. 2)

3. Next, **install the external wall bracket**. Place the mounting plate horizontally on the wall allowing 50mm clearance on both sides and mark the location for the wall plugs and the tube hole. Then drill the 6.5mm diameter and 32mm depth holes and fit the wall plugs. (Figs. 3 and 4)

4. **Secure the internal mounting plate** in seven places and check it is firm. Drill a 70mm diameter hole, to hold the electrical cables and refrigerant pipework, with a 5mm downward slant to the outside. Set the sleeve and the caps.

5. **Connect the electrical cable to the indoor unit**. Open the panel by about 70° and remove, and retain the screw from the indoor unit. Connect the electrical cable ensuring the markings on the indoor unit's terminal board match those of the outdoor unit. Be careful not to confuse the terminal connections as wrong cabling may damage the internal control circuit. Fix the cable with the cord holder and replace the retained screw. (Fig. 5)

6. **Mount the indoor unit to the wall**. Pass the auxiliary pipe and the drain hose through the piping hole and hook the unit onto the mounting plate. Push the unit and apply the bottom hooking points to the mounting plate's support. Check it is fixed in place by gently pulling the bottom of the unit.

7. **Connect the refrigerant and drain hose pipes***. Flare the end of the refrigerant pipe in order to connect. Lay the drain hose vertically to ensure a smooth drain flow with no traps. Tighten the pipes by hand for the first 3-4 turns and then use a wrench or torque spanner. Wind coating tape around the refrigerant pipes together with the drain hose and the electrical cable. (Fig. 6)

8. **Insulate the refrigerant pipes and drain hose**. The thermal insulation should cover both the gas and liquid pipes, using Class O insulation 6mm or thicker.

9. **Connect the refrigerant pipes and the electrical cable to the outdoor unit**. Prepare the end of the electrical cable and remove the control box cover. Remove the cable holder and connect the cable ensuring the terminal connections are as specified. Take care to dress the cable so that the control box cover, the cord holder and cable holder are not loose to avoid overheating, fire or electric shock. Fix the electrical cable sheath with the cable holder and the screw. Place the control box cover back in the reverse order. (Fig. 7)

10. **Prepare a dedicated power supply circuit**. The appliance should be installed in accordance with national wiring regulations. Provide an earth leakage circuit breaker and fit a disconnection switch, having a contact separation of at least 3mm in all poles to the electricity power line. (Fig. 8)

11. Complete the installation by doing a **test run**. Open the panel to view the control section, then start the operation with the remote control and press 'AUX' for five seconds or more. You should hear a beep sound and the 'operation' lamp will start to flash, indicating that the system is in the cooling test run mode. To test the heating mode simply select 'heating mode' on the remote control.

At Worcester we provide thorough training and a detailed commissioning check-list which ensures that everything is checked during the commissioning process. All Worcester trained installers give every customer a detailed handover explaining how the air source heat pump works. This ensures the customer is happy with their air source heat pump and understands fully how to operate it.

**It is a legal requirement for the connection of the refrigerant circuit to be carried out by a suitably qualified refrigeration engineer. The relevant Health and Safety procedures must be adhered to during installation.*

Installation requirements

System design requirements

The siting of the indoor unit should be mounted in a way that allows for free air movement; doors and walls restrict air movement if used for larger applications.

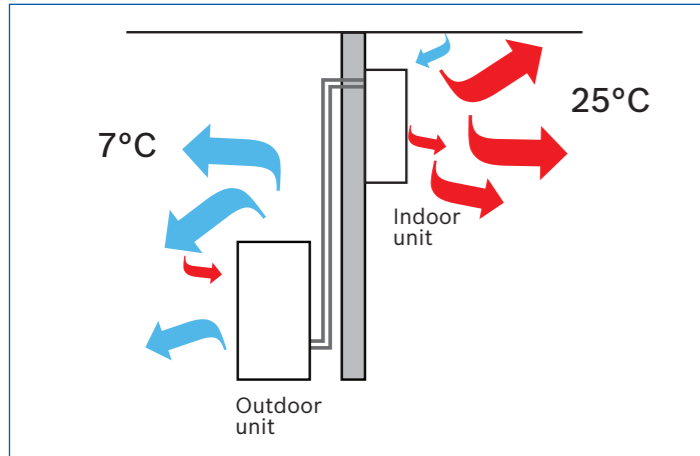

Typical temperatures in heating mode

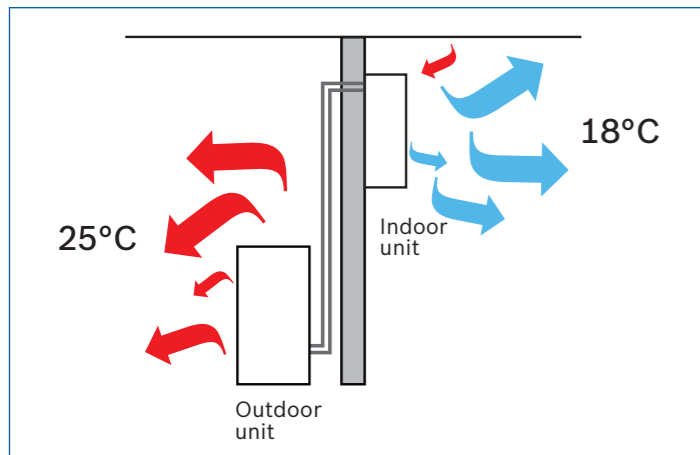

Typical temperatures in cooling mode

Connecting the outdoor and indoor units

The refrigerant circuit must be connected by a suitably qualified refrigeration engineer in conjunction with the installation manual supplied with the unit.

The electrical connections must be made by a qualified electrician using the latest IEE Wiring Regulations and the installation manual.

Only refrigerant grade copper pipe suitable for refrigerant R410A should be used. BS EN 12735-1:2001 copper and copper alloys. Seamless, round copper tubes for air conditioning and refrigeration. Tubes for piping systems.

System care

An air to air heat pump does not require annual servicing but it is advisable to follow a few simple maintenance procedures.

The outdoor unit should be checked regularly for leaves and debris, especially on the evaporation fins and water tray. The outdoor unit should be cleaned using a watering can with a rose attached. If the unit needs to be cleaned a car wash and polish can be used.

The indoor unit should be cleaned in accordance with the installation and user manual. For optimum performance the air filters should be removed and vacuumed each week.



Air filters should be removed and vacuumed each week

Heat pump sizing

Although the sizing of the heat pump can only be accurately carried out by taking all factors into consideration, this section offers some explanation of the principles behind the sizing of heat pump according to the energy requirement of the property.

The following examples are for demonstration purposes only:

A heat pump is designed to provide supplementary heating, and if it is the correct size for the area to be heated it should provide around 100% of the peak load of the room on the coldest day. One unit will typically heat an area of 80-140m² if correctly positioned.

As a general rule, it is more efficient to have the heat pump working as hard as possible as every kW of heating produced by the heat pump is more economical and environmentally-friendly than a kW produced by gas, oil or electricity.

There are significant climatic differences across the UK. For more information on the suitability of heat pumps for a particular property or application visit

www.worcester-bosch.co.uk

Typical examples of required heating loads (w/m²)

Small offices, apartments & conservatories	45
Offices (large)	40

Note: Heating is based on -1°C ambient and 1-2 air change per hour for average construction. Figures can be halved for modern and well-insulated buildings.

Typical examples of required cooling loads (w/m²)

Interior zones more than 7m from windows	75
Perimeter zones 25% glazing	100
Perimeter zones 60% glazing	160
Computer/print rooms	300 - 500

Refrigerants

The Worcester Greensource air to air heat pump system uses R410A, a non-ozone depleting pre-charged refrigerant.

Spare parts

Only genuine Worcester, Bosch Group spare parts can be used with these products.

Filters (2)

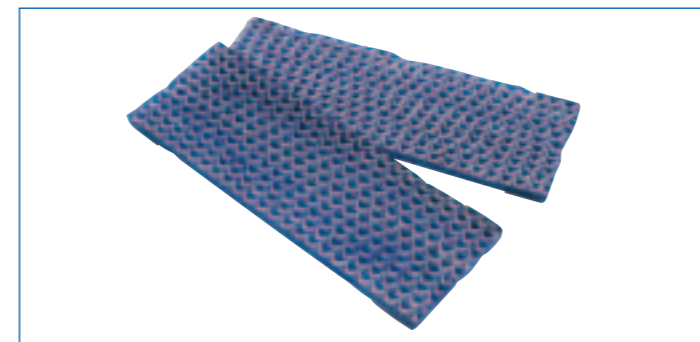

Part No. 8 716 115 433

Standards

The installation of the Worcester Greensource air to air heat pump system must be carried out in accordance with the relevant requirements for safety, current Wiring Regulations, local Building Regulations, Building Standards (Scotland), (Consolidation) Regulations and Bylaws of the local water company and Health and Safety document No. 63S (Electricity at Work Regulations 1989). It should be in accordance with the relevant recommendations of the following British Standards and Regulations:

BS EN 255 – replaced by BS EN 14511

BS EN 378

Refrigerating systems and heat pumps. Safety and environmental requirements.

The Health and Safety at Work Act 1974

The Management of Health and Safety at Work Regulations 1999

The Construction (Health, Safety and Welfare) Regulations 1996

The Construction (Design and Management) Regulations 1994

The Lifting Operations and Lifting Equipment Regulations 1998, and any other relevant regulations in force at this time.

The manufacturer's notes must not be taken in any way as overriding statutory regulations.

Government grants

From time to time the Government provides grants for the installation of renewable technology products. To find out more visit: www.dti.gov.uk

For details of grants available under the Government's Low Carbon Buildings Programme visit: www.lowcarbonbuildings.org.uk

The Code for Sustainable Homes

Why we need a Code for Sustainable Homes

Carbon emissions from domestic properties have to be reduced – a fact highlighted by statistics for 2004 which show that 73% of domestic CO₂ emissions are produced by the provision of heating and hot water.

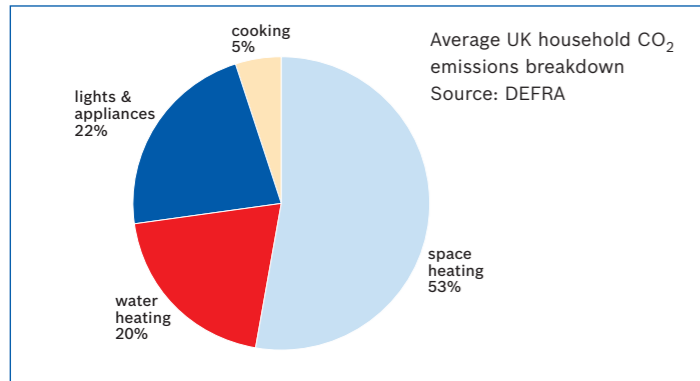

Worcester Greensource air to air heat pumps comply with the requirements for the Government's Code for Sustainable Homes, a major initiative which is designed to reduce domestic CO₂ emissions.

The purpose of the Code is

- to act as new single national standard for key elements of design and construction of sustainable homes
- an opportunity to build future housing stock that meets Britain's needs and protects the environment
- to act as a means of ensuring continuous improvement, greater innovation and exemplary achievement in sustainable home building
- to provide a standard which builds on the successful EcoHomes System devised by the BRE (Building Research Establishment).

The benefits of the Code

For the environment the benefits include:

- reduced carbon dioxide emissions (a major cause of climate change)
- better adaptation to climate change through measures such as improved water efficiency and management, household recycling and the use of less-polluting materials.

For new home builders the benefits include:

- satisfying the growing demand for new homes which are both more sustainable and more economical to run
- demonstrating the degree of this sustainability through the star rating
- establishing a competitive edge over lower-rated new homes
- finding innovative solutions to exceeding the Code's minimum requirements.

For social housing providers the benefits include:

- lower running costs (through greater energy and water efficiency)
- enhanced comfort and increased tenant satisfaction (so fewer complaints)
- continuing to meet or exceed the standards for funding.

For tenants and homeowners the benefits include:

- reducing their own environmental footprint
- enjoying lower running costs through greater energy and water efficiency than homes not built to Code standards
- benefits such as more natural light and other features and standards which enhance feelings of well-being which result in a more pleasant, healthier, living environment.

How the Code works

The Code measures a home's sustainability against these 9 design categories, rating the 'whole home' as a complete package:

- energy and CO₂
- materials
- waste
- health and well-being
- ecology
- water
- surface water run-off
- pollution
- management

- The Code's rating system uses stars to indicate a home's overall sustainability performance across the 9 design categories

- A home can achieve a rating of from 1 to 6 stars – 1 being the lowest (entry level) rating but above the level of the building regulations, and 6 reflecting exemplary standards in sustainability terms
- There are minimum standards for some categories, and these must be achieved to gain a 1-star sustainability rating
- Energy efficiency and water efficiency, vital to the sustainability of any home, also have minimum standards that must be achieved at every Code level
- Apart from these minimum requirements the Code is completely flexible, allowing developers to choose which and how many standards they implement to achieve a higher sustainability rating

- The table below shows the 9 design categories and the degree of flexibility offered by each:

Flexibility of the Code	
Categories	Flexibility
Energy/CO ₂	Minimum standards at each level of the Code
Water	Minimum standards at Code entry level
Materials	Minimum standards at Code entry level
Surface water run-off	Minimum standards at Code entry level
Waste	Minimum standards at Code entry level
Pollution	No minimum standards
Health and well-being	No minimum standards
Management	No minimum standards
Ecology	No minimum standards

- To achieve a particular Code level and the associated sustainability rating, a home must integrate minimum standards and attain additional points for other design features. The table below shows the minimum standards and number of points required to achieve each Code level.

Achieving a sustainable rating (minimum standards)					
Code Level	Energy		Water		Other points required
	Standard (% better than Part L1 2006 ¹)	Points awarded	Standard (Ltrs per person per day)	Points awarded	
1(★)	10	1.2	120	1.5	33.3
2(★★)	18	3.5	120	1.5	43.0
3(★★★)	25	5.8	105	4.5	46.7
4(★★★★)	44	9.4	105	4.5	54.1
5(★★★★★)	100 ²	16.4	80	7.5	60.1
6(★★★★★★)	Zero Carbon home ³	17.6	80	7.5	64.9

1. Building Regulations: Approved Document L (2006) – 'Conservation of Fuel and Power.'

2. Zero emissions in relation to Building Regulations issues (i.e. zero emissions from heating, hot water, ventilation and lighting).

3. A completely zero carbon home (i.e. zero net emissions of carbon dioxide (CO₂) from all energy use in the home).

All points are rounded to one decimal place.

Frequently asked questions

Where can a Greensource air to air heat pump be used?

Due to its compact size and ease of installation – 1/2 day is usually sufficient – a Greensource air to air heat pump is suitable for installation for a wide range of domestic and commercial properties.

The outdoor unit requires very little space if floor standing and its suitability for wall mounting increases the siting options still further.

What refrigerant is used in Greensource air to air heat pumps?

Greensource air to air heat pumps use R410A. It is an approved refrigerant featuring zero Ozone Depleting Potential. It also has a low Global Warming Potential which is more environmentally friendly.

What is the lower limit operating temperature?

The lower limit operating temperature of the outdoor Greensource air to air heat pumps is -20°C.

What are the key maintenance requirements for a Greensource air to air heat pump?

An air to air heat pump does not require annual servicing but it is advisable to follow a few simple maintenance procedures.

The outdoor unit should be checked regularly for leaves and debris, especially on the evaporation fins and water tray. The outdoor unit should be cleaned using a watering can with a rose attached. If the unit needs to be cleaned a car wash and polish can be used.

For optimum performance the air filters in the indoor unit should be removed and vacuumed each week.

How should the unit be sited to ensure the airflow and access it needs?

What's important is to ensure there is sufficient space for airflow into the unit and enough clearance at the front of the heat pump to stop cold air re-circulation. You'll also need to ensure that there is adequate space for access for service and maintenance. You should try to ensure that the unit is sheltered from high winds and rain as this will improve the unit's efficiency level by lowering the fan power requirement. The minimum clearances required are shown on page 14.

What size of cable should be used to connect the air to air heat pump to the mains electricity supply?

Consideration should be given to the size of the unit, the length of the cable run and the type of cable being used. Only have installation work carried out by qualified technicians who will be able to calculate the correct cable size for each installation. Wiring of the units must be in line with the latest edition of the IEE Wiring Regulations (currently the 17th edition in force since 1st July 2008) also known as BS 7671:2008.

Can the external air to air heat pump unit be hidden behind bushes, trees and fences?

Yes, but you have to be aware that wherever you position the unit it has to have adequate airflow available to it and that the discharge air can't be re-circulated back to the inlet. If you don't take enough care in this respect, it will result in lowering the air temperature and can significantly reduce the efficiency of the unit. Our recommended clearances should be noted on page 14.

Can an air to air heat pump be used to cool the home as well as providing heat?

A Greensource air to air heat pump can cool a property as well as heating it. It also has the added advantage of acting as an air purifier and dehumidifier.

What warranty is available?

Greensource air to air heat pumps come with a 2 year manufacturer's guarantee provided that the guarantee is registered within 30 days of installation. For more information please call 0845 725 6206.

Is there a training course available?

Yes, Worcester offers a range of training courses including a 1 day Greensource air to air training course. Please call 01905 752526 for more information.

Note: Only one indoor unit and one outdoor unit can be used together as a single split system.

Installation accessories

A number of accessories are generally available for use in the installation of Greensource air to air heat pumps. These include wall brackets, condensing unit drip trays and condensing unit guards.

The following companies have nationwide coverage and are able to supply all the necessary refrigerant fittings and accessories necessary for the installation of our Greensource air to air heat pump.

It is a legal requirement for the connection of the refrigerant circuit to be carried out by a suitably qualified refrigeration engineer.

Heronhill Air Conditioning Ltd

Tel: 01823 665 660

www.heronhill.co.uk

Wolseley Climate Centre

Tel: 01282 834 498

www.wolseley.co.uk

Dean and Wood

Tel: 0113 201 2851

www.dean-wood.co.uk

United Refrigeration

Tel: 01455 630 770

www.uriukltd.com

HRP

Tel: 01359 270 888

www.hrponline.co.uk



Wall bracket and condensing unit drip tray



Outdoor unit guard

A complete after-sales service

As part of the worldwide Bosch Group, Worcester strives to maintain the highest possible standards of after-sales care.

In addition to the no-nonsense parts and labour warranty applicable to all Worcester products, you and your customers have the assurance that every Worcester product is manufactured to both the appropriate British and European standards.

Worcester Contact Centre

Should you require support, our fully trained Contact Centre staff, based at our head office in Worcester, are ready to take your calls. Whatever your query our contact centre operators along with our nationwide team of engineers are ready to help you.

If you do not offer annual service and maintenance contracts please refer your customers to the Worcester Contact Centre:

Tel: 08457 256 206
Fax: 01905 757 536

Opening Times

Monday – Friday: 7.00am – 10.00pm
Saturday: 8.00am – 5.00pm
Sunday: 9.00am – 12 noon

All the technical advice you need

Spares

Genuine replacement parts for all Worcester products are readily available from stock, on a next day delivery basis. For more information please call your local stockist. You can find a spares stockist on our website.

Customer Technical Support

The Worcester Technical Helpline is a dedicated phone line – committed to providing a comprehensive service to complement the brand name and quality of our products. Our experienced team of technical experts provides the answers to queries of a technical nature across the entire Worcester range.

Worcester also has a pre-sales department, which provides assistance in selecting a product system to suit a particular application, along with full guidance on installation. As well as this we will also assist in finding a recommended installer. For more information please contact the Technical Helpline or alternatively visit our website where literature can be downloaded www.worcester-bosch.co.uk

Worcester System Design Service

Worcester is pleased to offer a full design service to specify the air to water heat pump system according to individual requirements.

Technical

Tel: 08705 266 241
Fax: 01905 752 741

Renewables Helpline

Tel: 01905 752780
Email: renewable.energy@uk.bosch.com

Opening Times

Monday – Friday: 7.00am – 8.00pm
Saturday: 8.30am – 4.00pm



The very best training programmes from Worcester

Worcester has always placed great emphasis on technical support and training for installers and service engineers. Today this need is greater than ever. The differences between a combi, conventional and system boiler are substantial, and the technology of each continues to advance at a rapid pace.

To ensure the highest levels of competence and expertise in the installation of all Worcester products, the company runs intensive training courses for installers, commissioning engineers and engineers involved with servicing and fault finding.

Courses available

Our training facilities offer a number of courses suitable for the installer and commissioning engineers, and a more in-depth course for the servicing and fault finding engineers.



Training Centres throughout the UK

Worcester's network of regional training centres are strategically located across the country and include the 'A' Rated Training Academy at the company's headquarters. This facility has recently been extended to include an oil-fired appliance workshop and a renewable energies workshop in addition to the extensive gas-fired training facilities.

In addition to these outstanding facilities there are centres at Clay Cross in Derbyshire and Bangor in Northern Ireland. Further 'A' Rated Academies are open at West Thurrock in Essex and Bradford in West Yorkshire as well as additional training opportunities available throughout the UK. Please phone 01905 752526 for more information about a course near you. Each course is run by specialist trainers and is superbly equipped to deliver a combination of classroom theory and practical hands-on experience that's second to none.

College-linked Learning

A number of the UK's leading proactive technical colleges are equipped with Worcester products and offer excellent practical tuition on a more local level.

Distance Learning/Web Based Learning

Worcester has produced a selection of Distance Learning CD ROMs/DVDs which are packed with information. Call 01905 752556 for your copies, or visit www.worcester-bosch.co.uk for information on Web Based Learning.

Mobile training

Our 7.5 tonne mobile oil training vehicle with working boilers, is now available throughout the country for hands-on oil training and OFTEC courses.

Courses on Air to Water and Air to Air are now available please check with your local Technical Sales Manager and the Worcester website www.worcester-bosch.co.uk. Phone 01905 752526 to book your place.

Get on course for a more profitable future now.

Call now for more information
01905 752526



www.worcester-bosch.co.uk



Worcester training courses

Worcester training courses	
Greenstar CDi and Highflow CDi gas-fired condensing combi boilers	
Models covered	Greenstar 27/30/37/42CDi Greenstar Highflow 440/550CDi
Duration	1 day
Greenstar i Junior and Si gas-fired condensing combi boilers	
Models covered	Greenstar 24/28i Junior Greenstar 25/30Si
Duration	1 day
Greenstar system and regular gas-fired condensing boilers	
Models covered	Greenstar 12/15/18/24Ri Greenstar 30/40CDi Conventional Greenstar FS 30/42CDi Regular Greenstar 30CDi System Greenstar 12/24i System
Duration	1 day
Greenstar Camray high efficiency condensing oil-fired boilers	
Models covered	Greenstar Camray (kitchen) Greenstar Camray (kitchen) System Greenstar Camray Utility Greenstar Camray Utility System Greenstar Camray External
Duration	1 day
Greenstar Danesmoor & Heatslave high efficiency condensing oil-fired boilers	
Models covered	Greenstar Danesmoor Greenstar Utility Greenstar Heatslave Greenstar Heatslave External
Duration	1 day
OFTEC Training	
OFTEC 101	
Covering	Domestic/Light Commercial Pressure Jet Commissioning and Servicing
Duration	3 day course (2 days training plus 1 days assessment)
OFTEC 105e	
Covering	Domestic/Light Commercial Pressure Jet Boiler Installation
Duration	1 day assessment
OFTEC 101 & 105e	
Covering	Domestic/Light Commercial Pressure Jet Installation, Commissioning and Servicing
Duration	3 day course (2 days training plus 1 days assessment comprising 2 theory and 1 practical)
OFTEC 600a	
Covering	Oil Tank Installation and Associated Controls
Duration	1 day assessment course
OFTEC 101/105e/600e	
Covering	Domestic/Light Commercial Pressure Jet Boiler Installation, Commissioning, Servicing and Oil Tank Installation and Associated Controls
Duration	4 days (2 days training and 2 days assessment)
Mobile OFTEC	
All above covered throughout the country on the mobile training vehicle as well as in all our centres.	

Certificate in Energy Efficiency for Domestic Heating Course	
Covering	Key elements of energy-efficient heating and hot water systems and products, compliance with the latest Building Regulations, how condensing boilers work and how they differ to non condensing products.
Duration	1 day
Unvented Cylinder Course	
Covering	All G3 Regulations for the Installation, Servicing and Commissioning of Unvented Cylinders. The course includes recognised accreditation by Logic Certification.
Duration	1 day
Greenskies Solar System	
Covering	Installation, Commissioning and Servicing The course includes recognised accreditation by Logic Certification for eligibility of low carbon buildings programme funding.
Duration	2 days
Greenstore Ground Source Heat Pumps	
Covering	Installation, Commissioning and System Design
Duration	2 days
Greenstore Heat Pumps – Air to Water	
Covering	Installation, Commissioning and System Design
Duration	2 days
Greenstore Heat Pumps – Air to Air	
Covering	Installation, Commissioning and System Design
Duration	1 day



Useful numbers

Sales

Tel: 01905 752640

Fax: 01905 456445

Renewables Phone Team

Tel: 01905 752780

Email: renewable.energy@uk.bosch.com

Spares Parts

Tel: 01905 752576

Fax: 01905 754620

Technical (Pre & Post Sales)

Tel: 08705 266241

Fax: 01905 752741

Service

Tel: 08457 256206

Fax: 01905 757536

Livingston (Scotland)

Fax: 01506 441687

Training

Tel: 01905 752526

Fax: 01905 752535

Literature Line

Tel: 01905 752556

or download instantly

from our website

www.worcester-bosch.co.uk



The Council for
Registered Gas
Installers



Member



In partnership with



energy saving trust™



Worcester, Bosch Group is a brand name of Bosch Thermotechnology Ltd.

This leaflet is accurate at the date of printing, but may be superseded and should be disregarded if specification and/or appearances are changed in the interest of continued improvement. The statutory rights of the consumer are not affected.

Part No. 8 716 115 438 A 09/08



BBT1646



Worcester, Bosch Group,
Cotswold Way, Warndon,
Worcester, WR4 9SW

Tel: 01905 754624 Fax: 01905 754619