



Greenstar system gas-fired condensing wall mounted boiler range

NEW
Greenstar
Comfort
controls



Worcester and you. Making a difference.

As part of the Bosch Group, Worcester products are designed and manufactured to provide customers with the highest levels of quality and reliability which are synonymous with the Bosch name throughout the world.

As part of Europe's largest supplier of heating products, Worcester, Bosch Group has the UK-based resources and support capability to offer you the value-added solutions you deserve. Worcester employs a nationwide network of Service Engineers and technically trained Field Sales Managers

supported by an experienced technical services team which is able to provide comprehensive support and advice from designing system layouts through to installation.

Worcester is dedicated to providing energy efficient gas- and oil-fired condensing boilers, as well as an extensive range of renewable technologies. All of our products have been developed and introduced with the aim of helping the UK to achieve the Government's efficiency targets.



BOSCH
Invented for life



The reception and main entrance at our Worcester headquarters

“At Worcester we recognise the vital role you play in the specification and installation of energy efficient appliances in homes across the UK. We will continue to invest in our products, people, facilities and added-value services to ensure you have all you require in order to deliver only the best solutions to your customers’ requirements.”

Carl Arntzen,
Managing Director,
Bosch Thermotechnology Ltd.

Contents

Page

The Greenstar system boiler range	4 - 5
Key features of the range	6 - 7
Greenstar CDi Classic System features and benefits	8 - 9
Inside story – Greenstar CDi Classic System	10 - 11
Greenstar i System features and benefits	12 - 13
Inside story – Greenstar 12i - 24i System	14 - 15
Inside story – Greenstar 27i & 30i System	16 - 17
The Greenstore unvented cylinder series	18 - 19
Controls	20 - 21
Wave – smart heating control	22 - 23
Site preparations and guidance	24 - 29
Installation requirements	30 - 31
Greenstar System Filter	32 - 33
Condensate pipework	34 - 35
The Worcester CondenseSure auxiliary siphon	36 - 37
Horizontal and vertical flue terminal positioning	38 - 39
Horizontal fluing options	40 - 42
Vertical fluing options	43 - 45
Plume management positioning and system options	46 - 49
Accessories	50 - 53
Training	54 - 56
After-sales	57



The Greenstar system boiler range



The Greenstar system range is part of a market-leading range of energy-saving condensing wall-mounted gas-fired boilers.

Higher efficiency, highly cost-effective

The Greenstar system boilers have an annual efficiency (SEDBUK 2005 value) of over 90%, efficiently producing heat for your heating and/or hot water system. Non-condensing boilers achieve around 78% efficiency.

To these major benefits you can add yet more: renowned Worcester quality and reliability; a range of outputs to satisfy the heating demands of a variety of households; and truly exceptional all-round value for money.

Why choose a system boiler?

A system boiler heats the central heating system directly and produces hot water that is stored in a hot water cylinder. When used in combination with a high performance Worcester Greenstore unvented cylinder rather than a vented cylinder, the result is fast hot water response times at the taps, more powerful showers and faster-filling baths – all with more economical running costs.

A system boiler and unvented hot water cylinder removes the feed, expansion and cold water storage cisterns needed in the roof space, creating a 'dry loft'. This reduces the risk of leaks or freezing and frees up the loft for other uses.



Greenstar 27i System

The Greenstar system range at a glance

		30CDi Classic System	35CDi Classic System	12i System	15i System	18i System	24i System	27i System	30i System
Part No.	NG	7 738 100 244	7 738 100 236	7 716 130 143	7 716 130 168	7 716 130 170	7 716 130 144	7 716 130 240	7 716 130 242
	LPG	7 738 100 233	7 738 100 237	7 716 130 150	7 716 130 169	7 716 130 171	7 716 130 149	7 716 130 241	7 716 130 243
Output kW to central heating (CH)	Min	7.7kW	7.7kW	3kW	5kW	6kW	7.2kW	7.03kW	7.03kW
	Max	30kW	34kW	12kW	15kW	18kW	24kW	27kW	30kW
CH temperature control		✓	✓	✓	✓	✓	✓	✓	✓
DHW temperature control		✓*	✓*	✓*	✓*	✓*	✓*	✓*	✓*
Modulating gas control		✓	✓	✓	✓	✓	✓	✓	✓
Natural gas		✓	✓	✓	✓	✓	✓	✓	✓
LPG boiler		✓	✓	✓	✓	✓	✓	✓	✓
Electronic ignition		✓	✓	✓	✓	✓	✓	✓	✓

*When a Worcester optional control and internal diverter valve kit is used.

Key features of the range

Why choose a Worcester Greenstar system boiler?

Worcester's extensive range of system boilers, now with Central Heating (CH) outputs from 12kW to 35kW, deliver high energy-efficiency and lower running costs for homeowners. They also achieve higher SAP or NHER ratings for new build properties when used in conjunction with a Greenstore unvented cylinder.



The Greenstar System range

In well-insulated new homes, where hot water performance is more of a factor than heating, the combination of a Greenstar boiler and Greenstore unvented cylinder may enable a system boiler with a lower CH output to be used. This reduces energy consumption even further while reducing the need for larger diameter gas pipes to allow for an easier installation.

All boilers in the range feature reduced electrical consumption in stand-by mode, along with anti-cycling and modulation control. Most models are compact enough to be installed in a standard kitchen cupboard without the need for ventilation.

Winner of Which? Best Buy awards in 2011, 2012, 2013 and 2014

For four consecutive years, in a survey of Which? members, the Worcester Greenstar gas-fired condensing boiler range has been presented with Best Buy awards.* In the latest survey, no other manufacturer scored higher for reliability and customer satisfaction.

Staying in control

All Greenstar system boilers are compatible with S and Y plan systems or can be used with a full range of Worcester intelligent plug-in controls when installed with an optional Worcester diverter valve kit. As well as enhancing energy efficiency, this arrangement means the boiler controls the pump directly, reducing the need to install additional valves and cabling.

Optional plug-in controls

A wide choice of optional controls is available with the Greenstar system series to enable your customers to select the type of control which best suits their individual requirements. The choice ranges from a simple-to-operate digital programmer to sophisticated wireless programmers, room thermostats and intelligent controls. These controls employ the latest digital technology and deliver high levels of functionality to maximise energy savings without compromising on comfort. By using low voltage power and wireless technology, the optional controls avoid the need to comply with Part P of the Building Regulations.

The complete system solution

Our Greenstore unvented and solar compatible unvented hot water cylinders provide fast re-heat times with excellent heat retention properties. The combination of a Greenstar system boiler and a Greenstore unvented cylinder delivers hot water to the taps at mains pressure, filling baths quickly and ensuring that showers are powerful and invigorating. For more information on our Greenstore unvented cylinder range, see pages 18-19.



NEW Worcester Greenstore unvented cylinder range



Solar water heating

When used in conjunction with a Greenstore solar compatible unvented cylinder, Greenstar system boilers can be fully integrated with a Greenskies solar water heating system, which has the potential to provide up to 60% of annual hot water requirements. Even if solar water heating is not required at the time of installation, installing a solar compatible unvented cylinder will enable the system to be upgraded easily in the future.



Greenskies Solar-Lux, Solar-Lifestyle, Solar-Lito and Greenstore solar compatible unvented cylinder

Fluing options

The Greenstar system range features 2 different sizes of multi-directional room sealed flue (RSF) systems, 100mm or 125mm diameter. Flues can be run horizontally or vertically with additional 90° or 45° in-line bends allowing changes of direction to provide an extremely flexible and versatile fluing system. This enables the appliance to be sited virtually anywhere. More details are shown on pages 38-49.

Gas and LPG options

Greenstar system boilers are manufactured in both natural gas and Liquid Petroleum Gas (LPG) variants. This gives a full range of fuel options and eliminates the need for fuel conversion.

5 year guarantee

All Worcester Greenstar system boilers are offered with a full 5 year guarantee* on parts and labour as well as 10 year guarantee* on the primary heat exchanger*.



The Greenstar condensing system range – features and benefits at a glance

Energy-saving & environmental

- SEDBUK A rating of 90.1% and above (2005 value)
- Simple and intelligent control options are available to optimise boiler efficiency
- Low electrical consumption in standby mode
- Aluminium-silicon heat exchangers deliver high efficiency and reliability
- Anti-cycle control
- The Greenstar CDi Classic System, 27 and 30i System models and 12i System deliver NOx values below 40mg/kWh – achieving 3 credits under The Code for Sustainable Homes.

Time- & labour-saving installation

- Wall frames and jig allow space for pipes behind the boiler as standard
- Vertical pre-piping assembly available as an accessory
- 12i - 30i System models come pre-wired
- All models come pre-plumbed
- Full range of Condensfit II™ flue options
- Multi-directional fluing means boiler can be sited in a wider variety of places
- Optional diverter valve accessory
- Earth bonding strip as standard with CDi Classic System boilers.

End user comfort and convenience

- Full 5 year guarantee on parts and labour as well as a 10 year guarantee on the primary heat exchanger*
- Boiler protection plans available for both new and out-of-guarantee Worcester Greenstar boilers
- Bosch renowned quality and reliability
- Built-in boiler frost protection
- Compact dimensions – Greenstar i System models
- Controls behind flap – aesthetically pleasing and minimises the risk of tampering with controls.

Greenstar CDi Classic System

Features and benefits

The award-winning Greenstar CDi Classic System is now available in 2 outputs, 30kW and the new 35kW. Our top-of-the-range system boilers are suitable for larger properties that demand high outputs – typically with more than three bedrooms.

The Greenstar CDi Classic System range uses the proven Worcester WB5 aluminium-silicon heat exchanger which features an extra-large surface area to optimise combustion efficiency. Other energy-saving features include low electrical consumption in standby mode, anti-cycle control and a modulating pump.

The Greenstar CDi Classic System range can be combined with our Greenskies solar thermal panels to provide efficient heating comfort and reducing the property's carbon footprint.

Greenstar CDi Classic System boilers are compatible with the full range of Worcester digital wireless and intelligent controls*.



Greenstar CDi Classic System now also available in a 35kW output

Installation benefits

- Boiler design and wall-mounting bracket allows space for pipes behind boiler
- Vertical pre-piping assembly accessory providing pre-formed copper pipe lengths allows top exit from the boiler
- Earth bonding strip supplied as standard
- Remote PRV option that can be positioned higher in the system for cellar installations
- Compatible with S and Y plan systems
- A rigid 22mm compression gas connection, eliminating the need for pre-fabricating the gas pipe onto the isolating valve
- Multi-directional fluing enables boiler to be located in a wider variety of places
- Full range of Condensfit II™ flue options in both 60/100mm and 80/125mm diameters with optional plume management kit available
- Clear display on fascia for temperature and commissioning settings
- Short-circuit proof PCB design that removes the need for fuses in the low voltage circuits.

Environmental benefits

- SEDBUK A rating of up to 90.3% (2005 value)
- WB5 heat exchanger delivers high efficiency
- Digital and intelligent control options available, optimising boiler efficiency and fuel consumption*
- Modulating pump uses less electricity than a fixed speed pump
- Low electrical consumption when the boiler is in standby mode
- Lead-free components
- Compatible with Worcester Greenskies solar thermal
- Electronic ignition which eliminates the need for the pilot light to be on at all times
- Anti-cycle and modulation control
- All boilers and components are 100% recyclable.

NEW features based on installer feedback

Following on from your feedback new features have been added to the CDi Classic System including a larger condensate siphon which reduces the risk of frozen condensate and in most cases means an external CondenseSure will not be required. The CDi Classic System range includes a paper wall mounting template to aid installation.

The pump has also been upgraded to a more efficient model which meets the forthcoming ErP legislation. In addition, as an optional accessory, Worcester now offers a remote PRV that can be positioned higher in the system for basement installations.

WB5 heat exchanger

The Worcester WB5 heat exchanger has been designed to optimise clean burning combustion over an extra-large surface area. Each heat exchanger is factory set and 100% tested so, as long as the gas inlet pressure is correct, commissioning is straightforward. The heat exchanger requires minimal servicing which means fewer spare parts during its lifetime.



WB5 Heat Exchanger

On the primary heat exchanger†



End user benefits

- Condenses in heating modes for optimum efficiency during operation
- Highly reliable heat exchanger
- Simple and intelligent control options* for improved boiler efficiency and user comfort
- Modulation control reduces electrical consumption
- Built-in frost protection of the boiler and surrounding pipes
- All models are available as natural gas and LPG
- Full 5 year guarantee on parts and labour†
- 10 year guarantee on Worcester primary heat exchanger†
- Boiler protection plans available
- Bosch renowned quality and reliability
- Which? Best Buy award-winning quality.



The Greenstar CDi Classic System boiler is recommended by the Energy Saving Trust (EST). The Energy Saving Trust is a non-profit organisation that provides free and impartial advice on how to save energy.



Inside story – Greenstar CDi Classic System condensing boiler

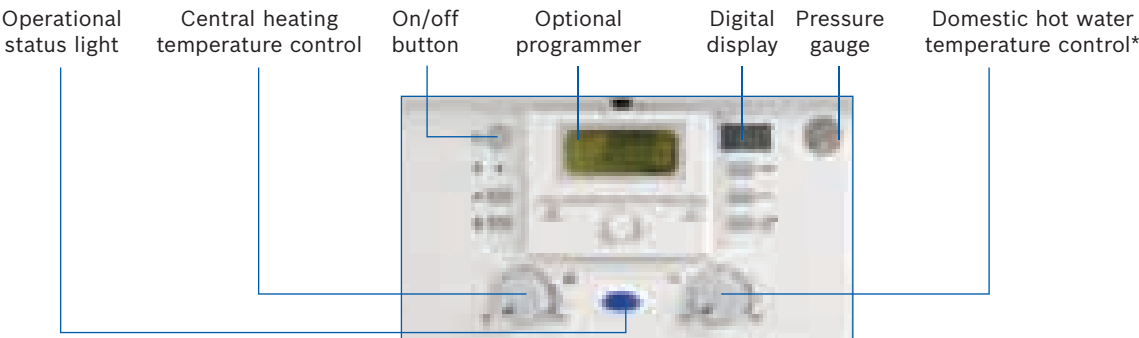
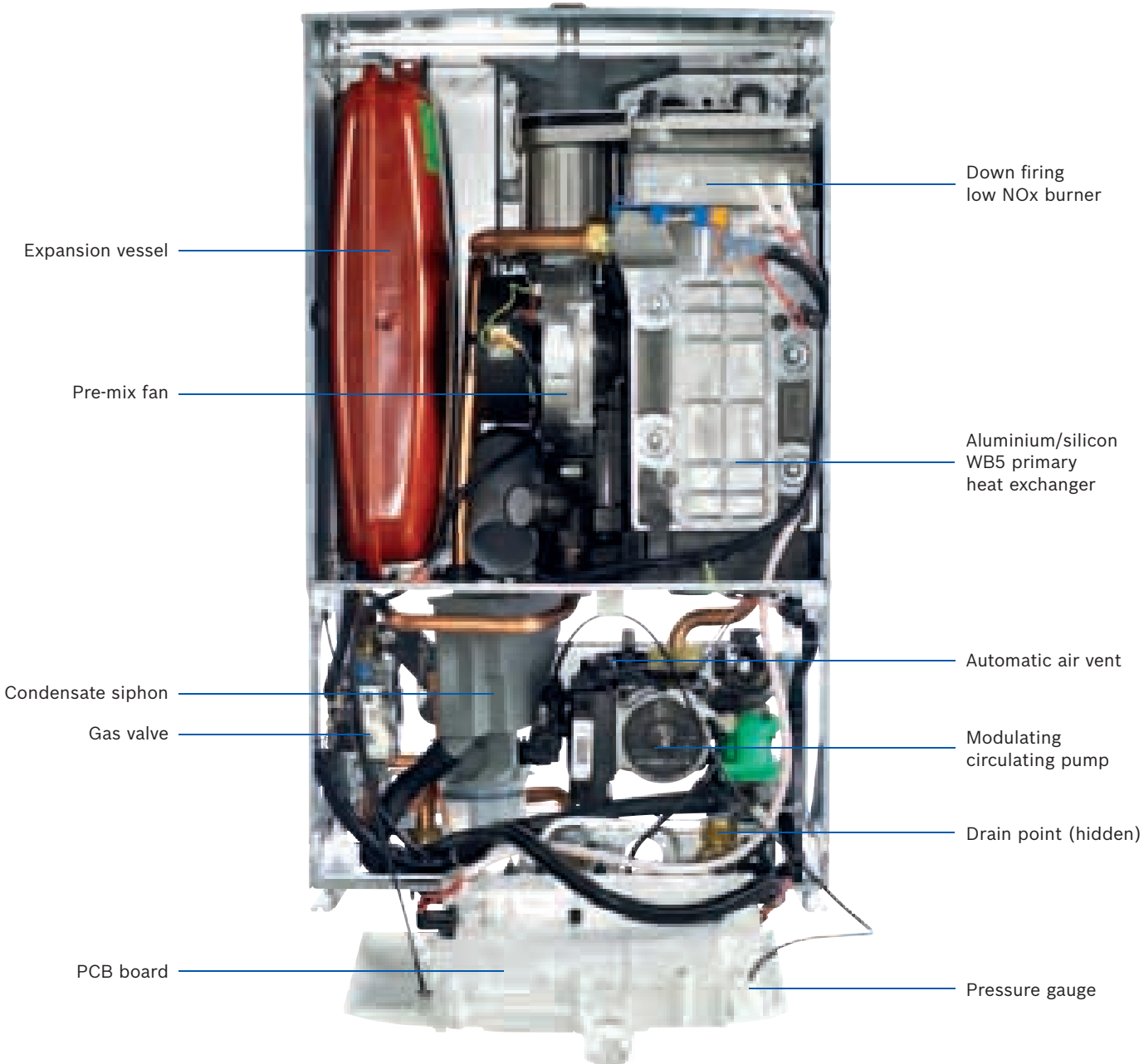

Greenstar CDi Classic System fascia with optional FW100 weather compensation controller fitted

*Only used with installation of optional integral diverter valve.

Technical data

Boiler	Greenstar 30CDi Classic System	Greenstar 35CDi Classic System
Height	760mm (max)*	760mm (max)*
Width	440mm	440mm
Depth	360mm (max)	360mm (max)
Weight – dry	46.5kg	46.5kg
2005 SEDBUK value – natural gas	90.2% / A rated	90.1% / A rated
2005 SEDBUK value – LPG	92.1% / A rated	92.0% / A rated
2009 SEDBUK value – natural gas	89.2%	89.2%
2009 SEDBUK value – LPG	90.2%	90.2%
Heating flow / return connections	22mm compression	22mm compression
Condensate connection	22mm plastic pipe	22mm plastic pipe
Gas connection	22mm compression	22mm compression
PRV connection	15mm compression	15mm compression
Primary water content	3.75 ltr	3.75 ltr
Output to central heating	7.7 - 30kW	7.7 - 34kW
Wall mounting jig	✓	✓
Diverter valve kit	✓ (optional)	✓ (optional)
Plug-in timers	✓ (optional)	✓ (optional)
Optimising room temperature controller	✓ (optional)	✓ (optional)
Intelligent controls	✓ (optional)	✓ (optional)
Modulating pump	✓	✓
Fault diagnostic display	✓	✓
Maximum vertical flue (100mm dia.) inc. terminal	9,400mm	8,000mm
Maximum vertical flue (125mm dia.) inc. terminal	18,500mm	16,000mm
Maximum horizontal flue (100mm dia.)	7,900mm	7,000mm
Maximum horizontal flue (125mm dia.)	18,500mm	16,000mm
NOx classification – natural gas	33.3mg/kWh	33.3mg/kWh
NOx class	5	5
Ingress protection (IP)	X4D	X4D

*Measured to the top or front of the curve height.

Greenstar i System

Features and benefits

The popular Worcester Greenstar i System range has been enhanced with the addition of two new higher output models. Complementing current CH outputs of 12kW, 15kW, 18kW and 24kW are new 27kW and 30kW models. This means Worcester Greenstar i System boilers are now suitable for an even wider range of properties with heating systems which include stored hot water.

Greenstar i System models have a robust, steel wall-mounting jig that allows sufficient space for pipes to go behind the boiler. This, along with the ability to pre-pipe all of the pipework before the boiler is sited, makes the i System quick and easy to install.

Despite the higher outputs, the new Greenstar 27i & 30i System boilers can be installed in a standard kitchen cabinet and can be used with a choice of Worcester simple and intelligent controls* for maximum end user flexibility and comfort, as well as reducing environmental impact.

The Greenstar i System can be used with our range of Greenstore unvented and solar compatible unvented cylinders for boiler-only and boiler/solar water heating systems respectively.

All boilers feature reduced electrical consumption in stand-by mode, anti-cycling and modulation control.

Installation benefits

- Robust, steel wall-mounting jig allows space for pipes behind boiler
- One man lift
- Pre-piping of all pipework before hanging the boiler
- 2m mains cable pre-wired to control box
- Boiler comes pre-wired and pre-plumbed for a time and labour-saving installation
- Compatible with S and Y plan systems
- Does not require compartment ventilation so long as minimum installation and service clearances are maintained (27 and 30kW)
- Full range of Condensifit II™ flue options in both 60/100mm and 80/125mm diameters
- Pre-set combustion settings for fast commissioning checklist data available on the boiler display (27 and 30kW)
- The expansion vessel has a simple drop lock mechanism that connects directly onto the hydraulic unit (27 and 30kW).

Environmental benefits

- SEDBUK A rating over 90% (2005 values) for all models
- Simple and intelligent control options available, optimising boiler efficiency and fuel consumption*
- Low electrical consumption when the boiler is in standby mode
- Heat exchangers deliver high efficiency and reliability
- Compatible with Worcester Greenskies solar thermal
- Electronic ignition which eliminates the need for the pilot light to be on at all times
- Integrated boiler bypass
- Anti-cycle and modulation control
- 27 and 30kW models have low NOx emissions – 3 credits under Code for Sustainable Homes.



New high output Greenstar i System 27 and 30kW models

WB3 heat exchanger

Greenstar i System 12, 15, 18 and 24kW boilers use the proven WB3 aluminium/silicon heat exchanger. The heat cell has an extra-large surface area for enhanced heat exchange efficiency.

WB7 heat exchanger

Greenstar i System 27 and 30kW models use the new WB7 heat exchanger which uses advanced friction stir welding* manufacturing technology to create more passageways than traditional heat exchangers. As a result, the WB7 heat exchanger delivers high outputs relative to its size.

Quality guaranteed

As part of our Total Quality Initiative programme, Worcester tests its boilers and heat exchangers using its own formula to replicate contaminated heating system water. This contains iron dust, quartz sand, hemp fibre and other contaminants found in such system water samples. This testing procedure ensures that all our heat exchangers are proven to be robust and efficient over the boiler's lifetime.



WB3 Heat Exchanger WB7 Heat Exchanger On the primary heat exchanger**



The Greenstar i System 12 to 24kW models

End user benefits

- Extremely reliable and efficient heat exchangers
- Compact dimensions – can be installed in a standard-sized kitchen cupboard (27 and 30kW)
- Option of simple and intelligent controls for higher efficiency and user comfort†
- Built-in frost protection of the boiler and the surrounding pipes
- All models available as natural gas and LPG
- Full 5 year guarantee on parts and labour**
- 10 year guarantee on Worcester primary heat exchanger**
- Boiler protection plans available
- Which? Best Buy award-winning quality.



The Greenstar i System boilers are recommended by the Energy Saving Trust (EST). The Energy Saving Trust is a non-profit organisation that provides free and impartial advice on how to save energy.



*The friction stir welding process is used under license from The Welding Institute. **Terms and conditions apply.

†With installation of optional integral diverter valve.

Inside story – Greenstar 12i - 24i System condensing boilers

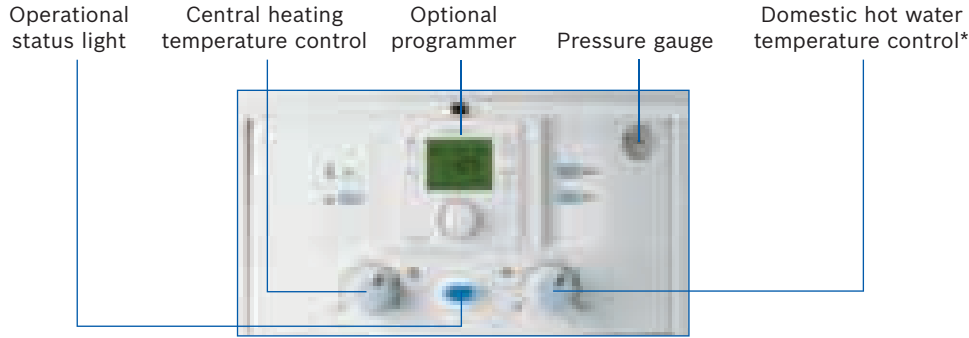
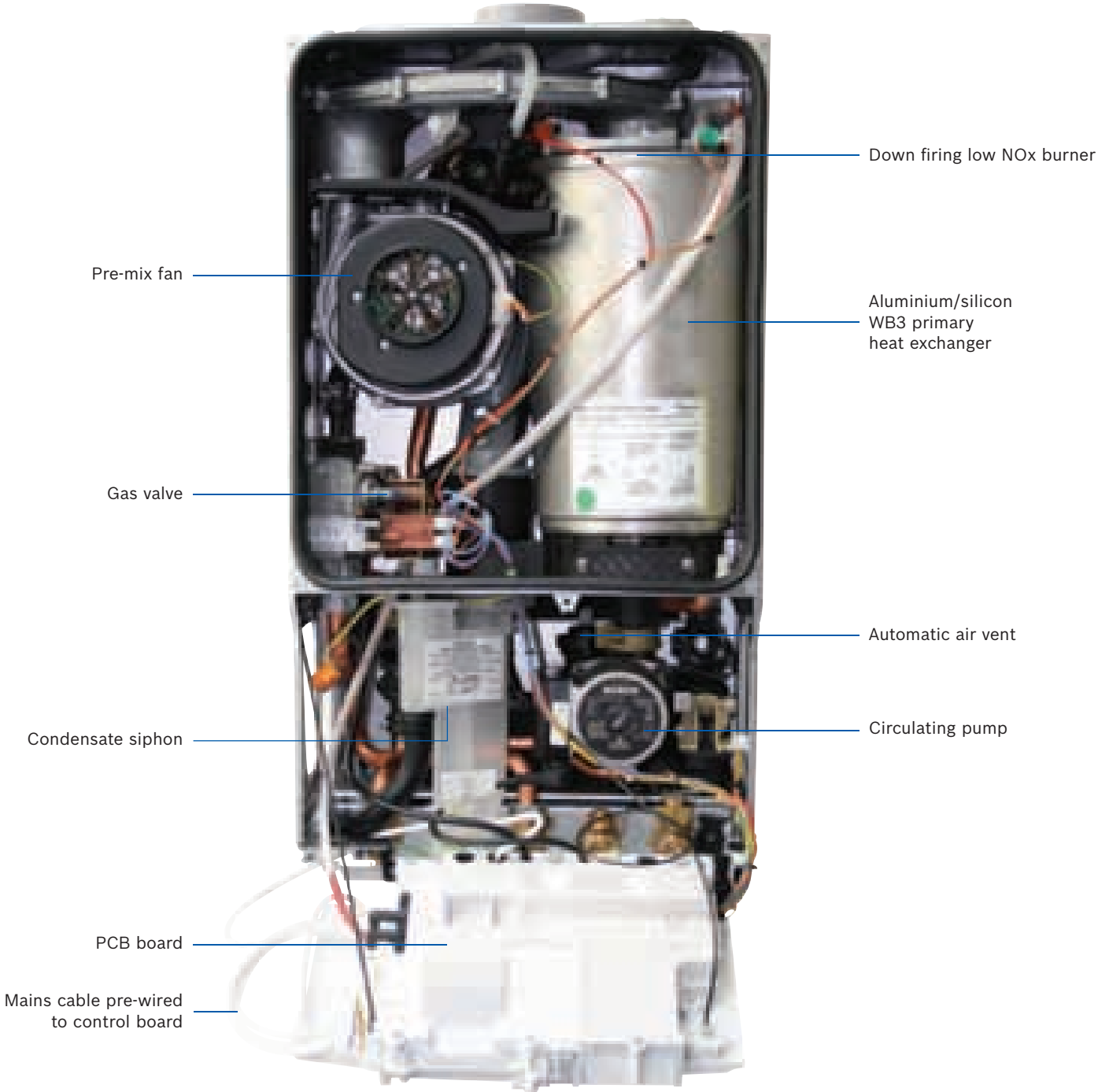

Greenstar 12i - 24i System fascia Comfort plug-in twin channel programmer fitted

**Only used with installation of optional integral diverter valve.*

Technical data

Boiler	Greenstar 12i System	Greenstar 15i System	Greenstar 18i System	Greenstar 24i System
Height	710mm (max)*	710mm (max)*	710mm (max)*	710mm (max)*
Width	400mm	400mm	400mm	400mm
Depth	330mm (max)*	330mm (max)*	330mm (max)*	330mm (max)*
Weight – lift	27.1kg	27.1kg	27.1kg	27.1kg
2005 SEDBUK value – natural gas	90.1% / A rated	90.1% / A rated	90.1% / A rated	90.2% / A rated
2005 SEDBUK value – LPG	91.4% / A rated	91.4% / A rated	91.4% / A rated	92% / A rated
2009 SEDBUK value – natural gas	88.8%	88.8%	88.8%	89.2%
2009 SEDBUK value – LPG	89.8%	89.8%	89.8%	90.2%
Heating flow / return connections	22mm compression	22mm compression	22mm compression	22mm compression
Pressure relief valve	15mm dia.	15mm dia.	15mm dia.	15mm dia.
Condensate connection	22mm plastic pipe	22mm plastic pipe	22mm plastic pipe	22mm plastic pipe
Gas connection	22mm compression	22mm compression	22mm compression	22mm compression
Primary water content	3.9 ltr	3.9 ltr	3.9 ltr	3.9 ltr
Output to central heating	3 - 12kW	5 - 15kW	6 - 18kW	7.2 - 24kW
Wall mounting jig	✓	✓	✓	✓
Plug-in timers	✓ (optional)	✓ (optional)	✓ (optional)	✓ (optional)
Diverter valve kit	✓ (optional)	✓ (optional)	✓ (optional)	✓ (optional)
Maximum vertical flue (100mm dia.) inc. terminal	6,400	6,400	6,400	6,400
Maximum vertical flue (125mm dia.) inc. terminal	15,000	15,000	15,000	15,000
Maximum horizontal flue (100mm dia.)	4,600	4,600	4,600	4,600
Maximum horizontal flue (125mm dia.)	13,000	13,000	13,000	13,000
NOx classification – natural gas	39mg/kWh	60mg/kWh	84mg/kWh	66mg/kWh
NOx class	5	5	4	5
Ingress protection (IP)	X4D	X4D	X4D	X4D

*Measured to the top or front of the curve height.

Inside story – Greenstar 27 & 30i System condensing boilers

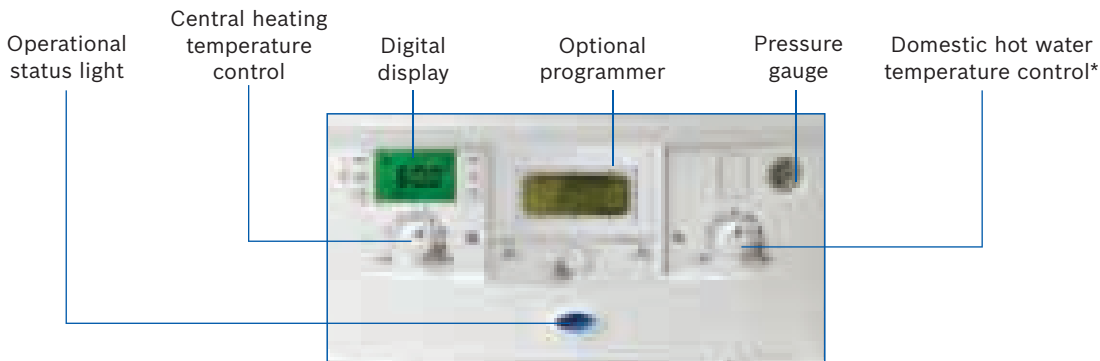
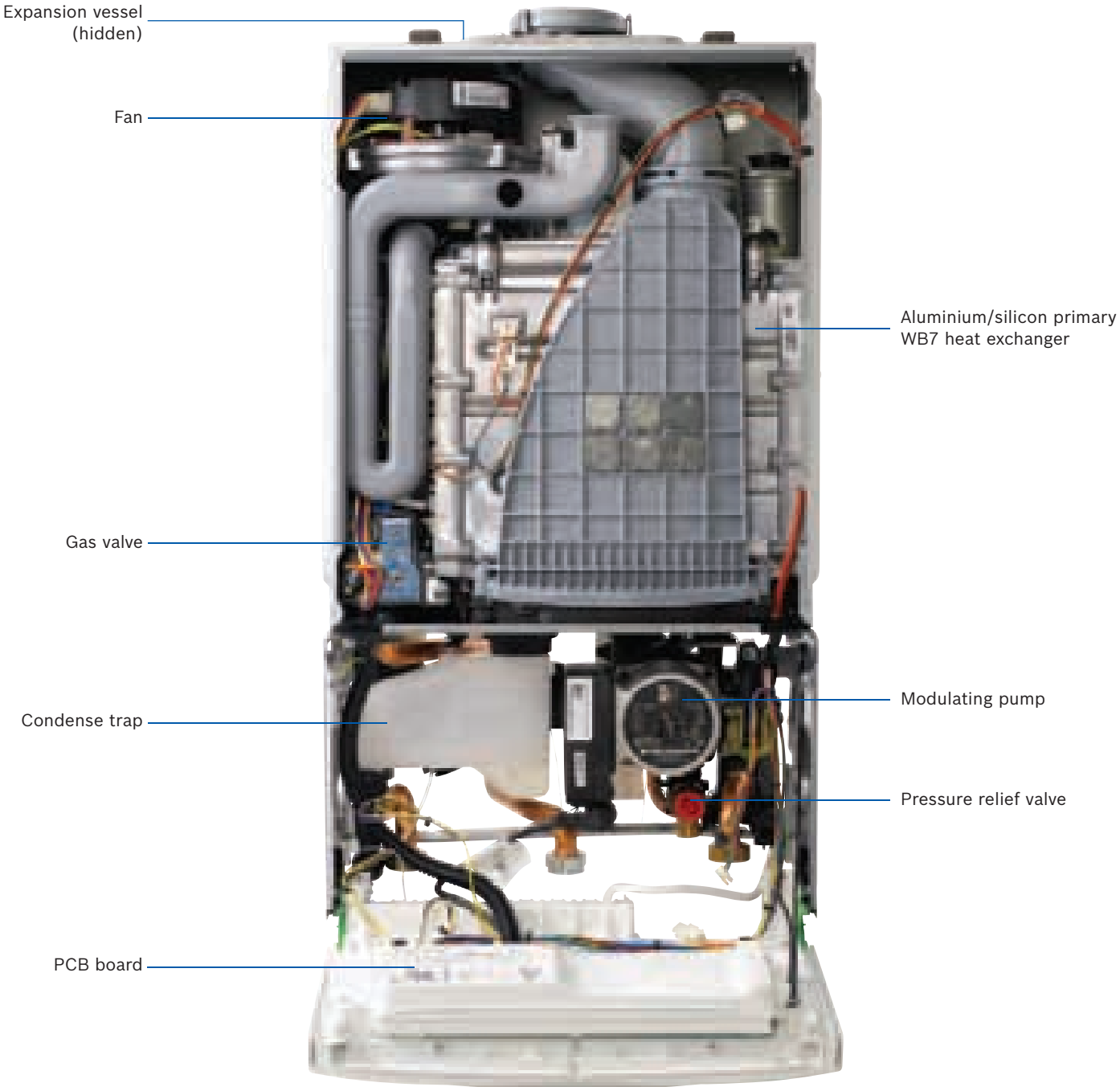

Greenstar 27i & 30i System fascia with optional FW100 fitted

*Only used with installation of optional integral diverter valve.

Technical data

Boiler	Greenstar 27i System	Greenstar 30i System
Height	690mm (max)*	690mm (max)*
Width	390mm	390mm
Depth	280mm (max)	280mm (max)
Weight – lift	27.3kg	27.3kg
2005 SEDBUK value – natural gas	90.3% / A rated	90.3% / A rated
2005 SEDBUK value – LPG	91.8% / A rated	91.8% / A rated
2009 SEDBUK value – natural gas	89.0%	89.0%
2009 SEDBUK value – LPG	90.0%	90.0%
Heating flow / return connections	22mm compression	22mm compression
Condensate connection	22mm plastic pipe	22mm plastic pipe
Gas connection	22mm compression	22mm compression
PRV valve connection	15mm compression	15mm compression
Primary water content	2.1 ltr	2.1 ltr
Output to central heating	7.03 - 27kW	7.03 - 30kW
Wall mounting jig	✓	✓
Plug-in timers	✓ (optional)	✓ (optional)
Diverter valve kit	✓ (optional)	✓ (optional)
Maximum vertical flue (100mm dia.) inc. terminal	6,000mm	6,000mm
Maximum vertical flue (125mm dia.) inc. terminal	15,000mm	15,000mm
Maximum horizontal flue (100mm dia.)	6,000mm	6,000mm
Maximum horizontal flue (125mm dia.)	15,000mm	15,000mm
NO _x classification – natural gas	35mg/kWh	35mg/kWh
NO _x class	5	5
Ingress protection (IP)	X4D	X4D

*Measured to the top or front of the curve height.



The Greenstore unvented cylinder series

Developed by Worcester. Built by Bosch.

Worcester offers a range of Greenstore high-efficiency unvented cylinders which provide excellent hot water comfort for properties with a stored DHW supply. They are available in both an unvented and solar compatible unvented option. The Greenstore unvented cylinder is available in seven different models ranging from 93L to 292L. The Greenstore solar compatible unvented cylinders are available in five options ranging from 158L to 287L.

The Worcester Greenstore unvented cylinder series is fully compatible with a wide range of non-Worcester boilers and solar panels, although to achieve the optimum system solution, it is recommended that a Greenstore unvented cylinder is coupled with either a Greenstar high-efficiency boiler or Greenskies solar panel installation.

The Greenstore unvented series

The Greenstore unvented cylinder benefits consumers who do not require solar compatibility, but are looking for a cylinder which offers high levels of insulation, excellent flow rate and outstanding re-heat performance. The Greenstore unvented range is also ideal for consumers who require a smaller capacity of hot water storage, with the unvented series being available in SC-90 and SC-120 variants.

The Greenstore solar compatible unvented series

All of the models in the solar compatible unvented cylinder series feature high levels of insulation and dedicated solar volumes in compliance with current Building Regulations, SAP 2012 and the Microgeneration Certification Scheme (MCS). Worcester's Greenstore solar compatible unvented stainless steel cylinders have been specifically designed for use with solar heating installations, combined with boiler back-up.



Features and benefits

Energy efficiency – high levels of heat retention

A critical factor that affects the performance and the overall efficiency of any hot water storage cylinder is the level of insulation that it can provide. Greenstore unvented cylinders feature extremely high heat retention levels, made possible by the 65mm of factory-fitted EPS (Expanded Polystyrene) insulation.

As well as satisfying the new-build requirements of SAP, the benefits could include lower energy consumption and heating bills for the end user.



Outstanding re-heat performance

When supplying large volumes of hot water to multiple outlets simultaneously, a cylinder's re-heat performance is crucial to providing a continuous flow.

Worcester Greenstore unvented cylinders feature high-quality heat exchange coils maximising heat transfer and providing quick hot water replenishment.

Cost-effective hot water solution

Everything you need with Greenstore unvented cylinder models can be ordered via a single part number. You will receive a full G3 accessory kit including:

- Tundish (15/22mm)
- Inlet control group
- 2-port motorised valve
- Expansion vessel
- Dual thermostat
- Connection set
- Solar high limit thermostat (solar compatible series only).

All of the G3 accessories are pre-adjusted. These high quality controls have been specifically selected to ensure a high flow rate performance with a minimum pressure drop, allowing the Greenstore unvented cylinders to perform well even in low pressure areas.

Greenstore unvented cylinder series at a glance

Unvented	Greenstore SC-90 Cylinder	Greenstore SC-120 Cylinder	Greenstore SC-150 Cylinder	Greenstore SC-180 Cylinder	Greenstore SC-210 Cylinder	Greenstore SC-250 Cylinder	Greenstore SC-300 Cylinder
Part no.	7 716 842 027	7 716 842 028	7 716 842 029	7 716 842 030	7 716 842 031	7 716 842 032	7 716 842 033
Height	835mm	1,035mm	1,285mm	1,490mm	1,665mm	1,860mm	2,155mm
Diameter	570mm	570mm	570mm	570mm	570mm	570mm	570mm
Weight – dry	26kg	31kg	36kg	40kg	44kg	48kg	54kg
Volume domestic hot water	93 litres	123 litres	161 litres	191 litres	216 litres	246 litres	292 litres
Standing heat loss – 24hr	0.72kWh/24hrs	1.06kWh/24hrs	1.35kWh/24hrs	1.54kWh/24hrs	1.67kWh/24hrs	1.93kWh/24hrs	2.17kWh/24hrs

Solar compatible	Greenstore TC-150 Cylinder	Greenstore TC-180 Cylinder	Greenstore TC-210 Cylinder	Greenstore TC-250 Cylinder	Greenstore TC-300 Cylinder
Part no.	7 716 800 542	7 716 800 543	7 716 842 042	7 716 842 043	7 716 842 044
Height	1,285mm	1,490mm	1,665mm	1,860mm	2,155mm
Diameter	570mm	570mm	570mm	570mm	570mm
Weight – dry	41kg	45kg	50kg	54kg	60kg
Volume domestic hot water	158 litres	187 litres	211 litres	241 litres	287 litres
Standing heat loss – 24hr	1.27kWh/24hrs	1.31kWh/24hrs	1.42kWh/24hrs	1.52kWh/24hrs	1.93kWh/24hrs
Dedicated solar volume	65 litres	65 litres	105 litres	115 litres	115 litres

Controls

5 year guarantee

When purchased and installed at the same time, the guarantee period for a Worcester control will match that of a Greenstar gas-fired boiler*.



Optional diverter valve required

System boilers using a Worcester control option are compatible with Y or S plan systems provided the optional diverter valve kit is fitted.

Advanced intelligent controls

FW100 – Weather compensation controller – Part no. 7 716 192 067

- Boiler output automatically adjusts to precisely meet the heat demands of the property according to outside temperature conditions at maximum efficiency
- Programmable unit with six switching points a day for control of both central heating and hot water pre-heat
- Choice of six selectable weekly programmes
- Can be integral to the boiler or wall-mounted
- Has factory-set heatcurves for various different heating systems (radiators, underfloor etc.)
- Manual-override that can boost or reduce heating if required.

FR110 – Programmable room thermostat – Part no. 7 716 192 066

- Intelligent programmable room thermostat
- Load compensation
- Choice of six selectable weekly programmes
- Six switching points a day for central heating and hot water pre-heat
- Boiler output automatically adjusted to precisely meet the heat demand of the property at maximum efficiency
- Maximises the condensing boiler's operation.

FR10 – Intelligent room thermostat – Part no. 7 716 192 065

- Load compensation
- Boiler output automatically adjusted to precisely meet the heat demand of the property at maximum efficiency
- Maximises the condensing boiler's operation
- For use with a 230V programmer. Not compatible with Worcester Comfort controls.

Greenstar Comfort controls



Comfort plug-in twin channel programmer – Part no. 7 733 600 003

- Simple menu navigation
- 7-day time control for heating and hot water
- Heating programme visualisation bar.

Comfort I RF wireless room thermostat and plug-in twin channel programmer – Part no. 7 733 600 001

- All the features of Comfort **PLUS**...
- Enhanced load compensation for increased efficiency
- No wiring required
- Extremely reliable RF signal.

Comfort II RF wireless programmable room thermostat and plug-in RF receiver – Part no. 7 733 600 002

- All the features of Comfort and Comfort I **PLUS**...
- 6 adjustable heating temperatures per day
- Set programme at the room thermostat
- Remote access to boiler diagnostic codes
- Back lit display.

Controls at a glance

Control option	TYPE			MOUNT		TIME CONTROL				TEMPERATURE CONTROL				CONNECTION TYPE			MODEL			
	Digital	Intelligent	Internet	Fascia mounted	Wall mounted	Central heating	Hot water	24 hour	7 day	Auto switch – BST/GMT	Room thermostat	Programmable room thermostat	Optimum start	Boiler flow temp compensation	Plug-in	Radio frequency	Hard wired	CDi Classic System	12i-24i System	27i & 30i System
Comfort	✓			✓		✓	✓		✓	✓				✓				✓ ¹	✓ ²	✓
Comfort I RF		✓		✓	✓	✓	✓		✓	✓			✓		✓			✓ ¹	✓ ²	✓
Comfort II RF		✓			✓	✓	✓		✓	✓			✓		✓			✓ ¹	✓ ²	✓
FR10		✓			✓						✓		✓				✓			✓
FR110		✓			✓	✓	✓		✓	✓		✓	✓				✓	✓ ¹	✓ ²	✓
FW100		✓		✓	✓	✓	✓		✓	✓			✓	✓			✓	✓ ¹	✓ ²	✓
ISM1																	✓	✓ ¹	✓ ²	✓
Wave		✓	✓		✓	✓	✓		✓	✓		✓	✓				✓	✓ ¹	✓ ²	✓

¹ Manufactured after 16th January 2007 with software version CF12.10 onwards.

² Manufactured after February 2011.

Worcester Wave – smart control for heating and hot water

The Wave is the first of a new generation of Worcester controls.

The Wave is a smart, internet-connected programmable control for central heating and hot water which can be operated using a smart device.

The Wave’s innovative programming enables it to have an ‘intelligent conversation’ with the boiler and take advantage of advanced control features such as weather and load compensation.

Enhanced energy efficiency

In the forthcoming ErP Directive (Energy-related Products Directive) coming out of Europe, smart controls like the Wave are recognised as improving the system efficiency by at least 4%, resulting in lower fuel bills.

The Wave’s energy efficiency features include:

- Charts of heating and hot water usage so the homeowner can easily identify where potential savings could be made.
- When the room temperature is turned down a leaf symbol will appear to indicate additional savings are being made.



Adapting to the homeowner’s needs

Each Wave unit is supplied with a pre-set programme that can then be easily modified to suit the user’s requirements.

The Wave’s advanced user features include:

- ‘Pairing’ with up to eight devices, automatically sensing when people are at home.
- Sensing to an individual device can be turned off if required.
- The Wave will remember preferred programme settings to make these easily available and features a ‘holiday programme’, requiring just a start and finish date.
- Unlike most other smart heating controls, the Wave can also programme the hot water settings, providing additional energy savings and comfort.
- For security and peace of mind, all of the Wave’s data is owned by the user, ensuring no information is shared with other parties.

Wave compatible devices:*

Apple® devices running iOS 5.1 and higher

Android™ devices running 2.2, 2.3 or 4.0 and higher

Features	Benefits
Only a low voltage 2-core wire connection between the controller and the boiler	Easy to install, all other connections are via the Wi-Fi network
Remote control of heating AND hot water via app	Programme the heating system from outside the home
Load and weather compensation via the internet (no outdoor sensor required)	Allows the boiler to modulate its performance to meet the needs of each household
Intuitive and modern design	Ensures easy programming and control of the boiler, resulting in a simple hand over with the end-user
Energy graphs, presence detection and many more features come as standard	Ensures increased comfort and energy savings
No subscription fees or chargeable app add-ons	One-off cost



Quick to install

The Wave is quick and easy to install:

- Only requires a 2-core wire connection between the control and the boiler.
- All other connections are via the Wi-Fi network.
- The Wave does not need an external wired sensor unlike standard weather compensation controls.
- The Wave uses online data which significantly reduces installation time and cost to the end user.

As with all room heating controls the Wave should be sited where it can monitor the overall temperature of the property.



Compatibility with Worcester Greenstar boilers

Ideal for homes and small businesses, the Wave is compatible with all current Worcester Greenstar gas-fired combination and system* boilers. It can also be retrofitted for use with previous Worcester EMS-bus appliances.

All you need is:

- Worcester Wave control
- Worcester compatible boiler[^]
- Wi-Fi enabled broadband router – 802.11 b/g
- Wave app on a compatible Apple® or Android™ device.

Part number	Description
7 716 192 072	Wave



Simple to use, providing an easy handover

The Wave's intuitive and modern design ensures it is very simple to operate using either its in-built touchscreen or via the Wave app.

- Users simply download the Wave app to their compatible device to take control of their heating system from anywhere in the world where an internet connection is available.
- There are no subscription fees or chargeable app add-ons, therefore updates to the app software are completely free of charge.
- An installation and operating manual is provided with each control and there are a number of helpful videos to provide further detail on specific functions.
- Should the Wave temporarily lose the internet connection, it will continue to operate as an intelligent heating and hot water control simply by using the last saved programme settings.



^{*}When installed with an optional Worcester Diverter Valve. [^]Correct at time of printing. For the latest list of compatible boilers see the Worcester website.

Site preparations and guidance

All system boilers are easier to install than conventional boilers and consequently require less time. The major benefits of the Greenstar system boiler are:

- Built-in pump, expansion vessel, pressure relief valve and pressure gauge
- There is less pipework
- There is no feed and expansion cistern in the loft space.

The System series also features:

- The boiler comes pre-wired and pre-plumbed
- The boiler can be connected to either low-pressure open-vent cylinders or mains pressure unvented units
- The boiler is compatible with S and Y plan systems
- The boilers come supplied with a wall-mounting jig
- A siphonic condensate trap is pre-plumbed within the boiler
- Automatic gas pressure adjustment
- Highly versatile multi-directional fluing system
- Combined ignition and control board means fewer connections.

Siting of appliance

The appliances are to only be installed internally within a property, at a suitable location onto a fixed, rigid surface, that is at least the same size as the appliance and is capable of supporting its weight.

Mounting on a combustible surface

All Greenstar wall-mounted boilers can be sited on a combustible surface without the need for surface protection. EN482, Section 6.4.1.3 states no means for protection of combustible surfaces is necessary if the temperature of the wall does not exceed the room temperature by more than 60°C. Testing of Greenstar gas-fired wall-mounted boilers has shown that this temperature is not exceeded.

However, if the appliance is to be fitted in a timber frame building, the guidelines laid down in BS 5440:Part 1 and the Gas Safe publication "Gas Installations in Timber Frame Buildings" should be adhered to.

The appliances may be installed into an airing cupboard if required. However, a non-combustible perforated material (max. hole sizes of 13mm) must be used to separate the boiler from the airing space. See section "Boiler location" on page 25.

Installation and service clearances

The minimum clearances shown below should be allowed for installation and servicing. Compartment ventilation would only be required at these clearances for the Greenstar 12-24i System range. The **Greenstar CDi Classic System and 27 & 30i System models do not require compartment ventilation so long as minimum installation and service clearances are maintained**, see below.

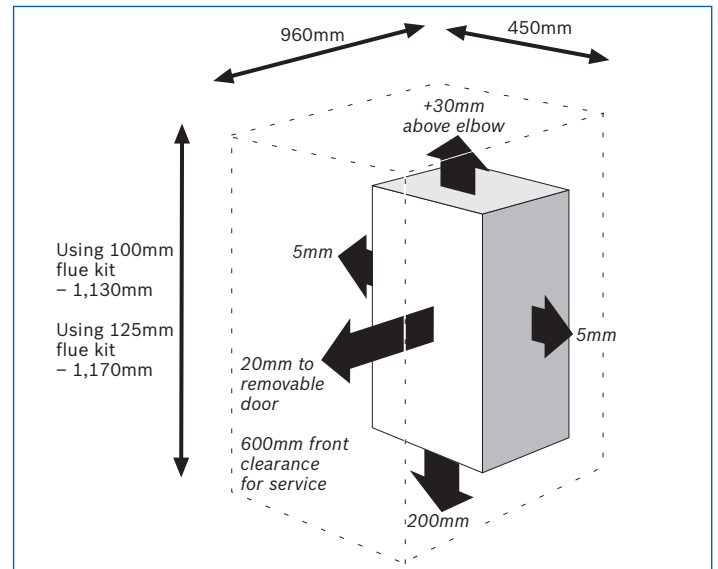

Clearances for Greenstar CDi Classic System

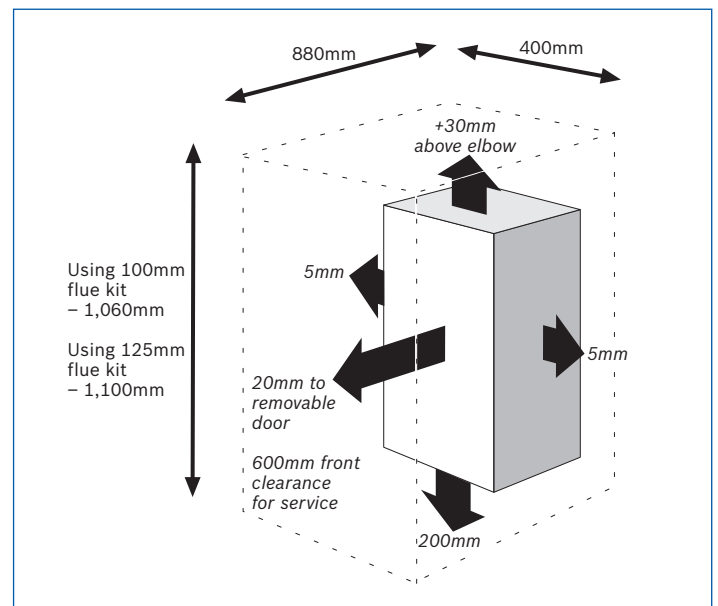

Clearances for Greenstar 27i & 30i System

Ventilated compartment installation – minimum clearances

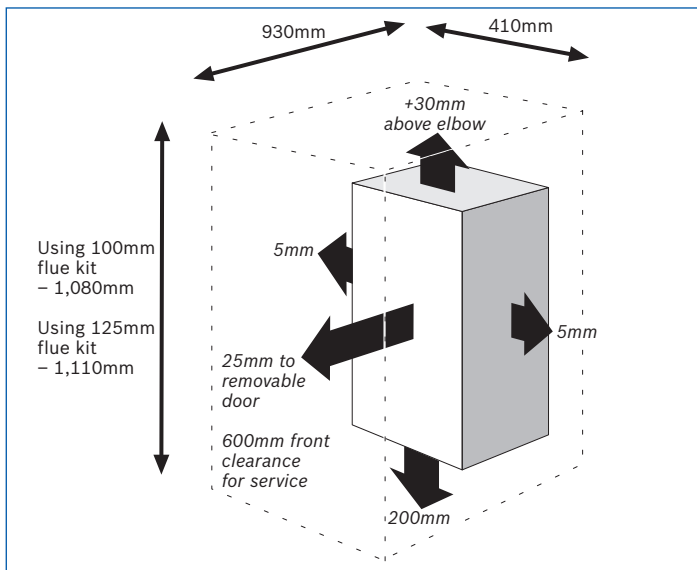

Clearances for Greenstar 12i-24i System

Ventilation-free compartment installation – minimum clearances

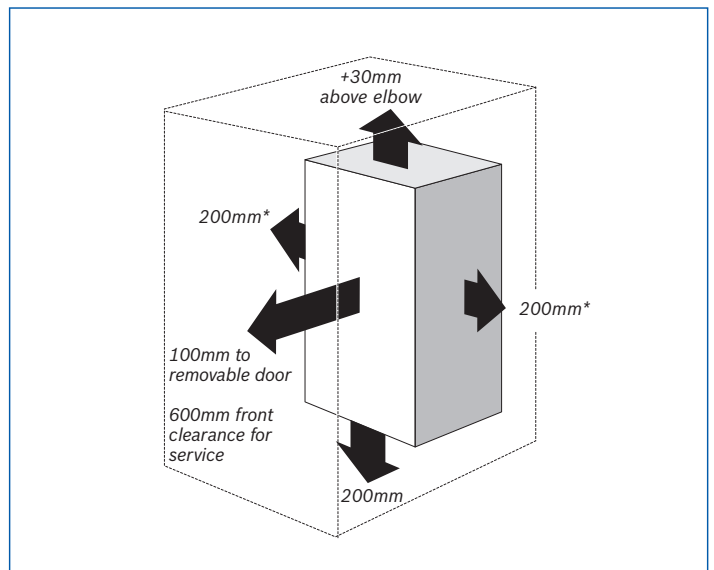

Greenstar 12i-24i System

*This can be reduced to 50mm for one side, provided that the total side clearances add up to 400mm or more.

Boiler location

The appliance may be installed in any room, although particular attention is drawn to the requirements of the IEE regulations applicable and, in Scotland, the electrical provisions with respect to installation in a room containing a bath or shower.

1. The room in which the appliance is installed does not require a purpose-provided air vent.
2. If the appliance is installed in a cupboard or compartment with dimensions that allow the following minimum clearances, then no ventilation is required:

Compartment installation			
Position of appliance	Min. unventilated clearance (to removable door)		
	Greenstar CDi Classic System	Greenstar 12i-24i System	Greenstar 27i & 30i System
In front	20mm	100mm	20mm
Below	200mm	200mm	200mm
Right side	5mm	200mm*	5mm
Left side	5mm	200mm*	5mm
Above flue elbow	30mm	30mm	30mm

*This can be reduced to 50mm for one side, provided that the total side clearances add up to 400mm or more.

Important: bathroom locations and clearances

- The boiler must not be installed in Zone 1
- Any switch or appliance control using mains electricity must not be within reach of a person using the bath or shower
- Electrical switches (other than pull cords), fused spurs and socket outlets must not be situated in the bathroom
- A boiler fitted with an FW100 controller may only be installed in the shaded area outside of zone 2. A boiler with any other timer fitted (or blanking panel for an optional programmer) can be installed in zone 2.
- Additional Residual Current Device (RCD) protection may be required.

Refer to the latest IEE wiring regulations.

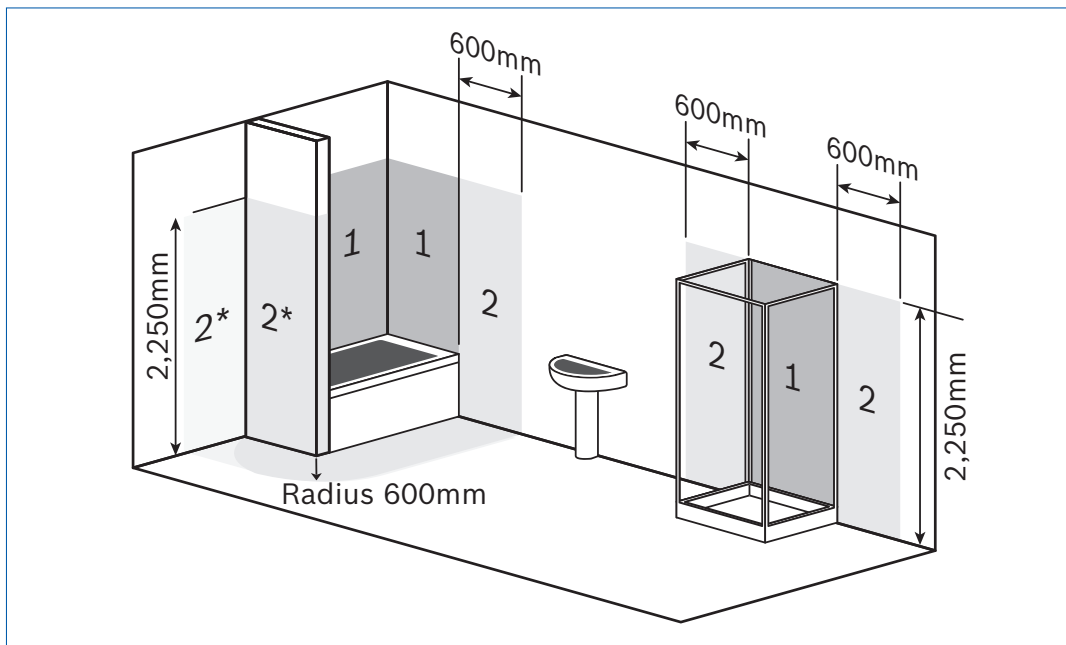

**Without the end wall, zone 2 must extend 600mm from the bath*

Wall preparation

The following diagrams show the wall-mounting jigs which enable a simple and straightforward method of attaching the boiler to the wall surface.

The new design wall-mounting jig for the Greenstar i System boiler is made from lightweight steel.

The Greenstar CDi Classic System boiler wall-mounting jig has additional optional fixing points and provides improved engagement. After fixing the jig to the wall, the boiler can be lifted onto the jig and the union connections tightened.

For all boilers, the pipework can be routed behind the boiler without the need for an additional wall-spacing frame.

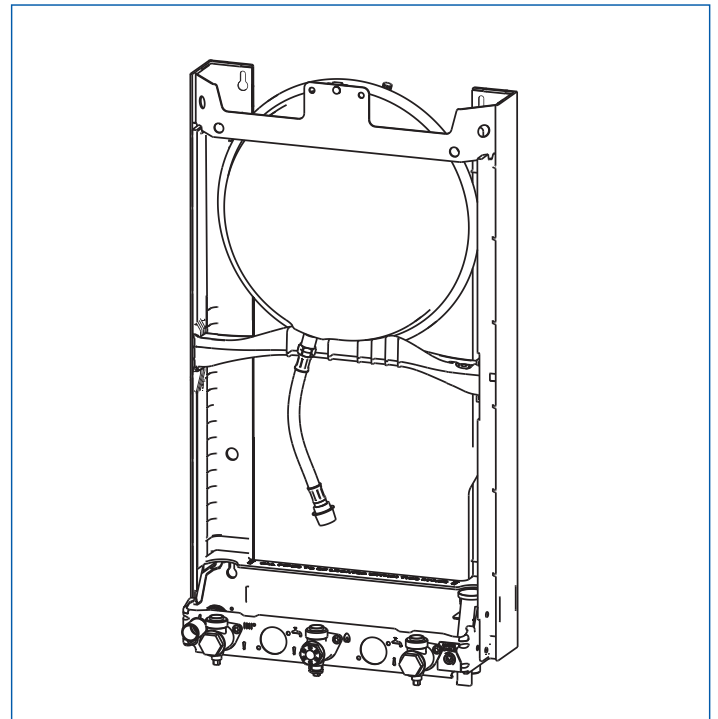

Greenstar 12i-24i System boiler wall-mounting jig

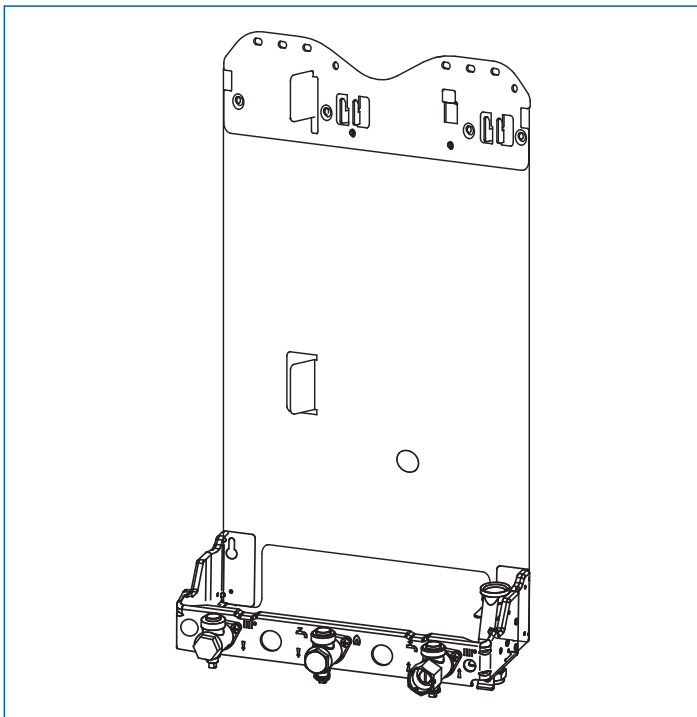

Greenstar CDi Classic System boiler wall-mounting jig

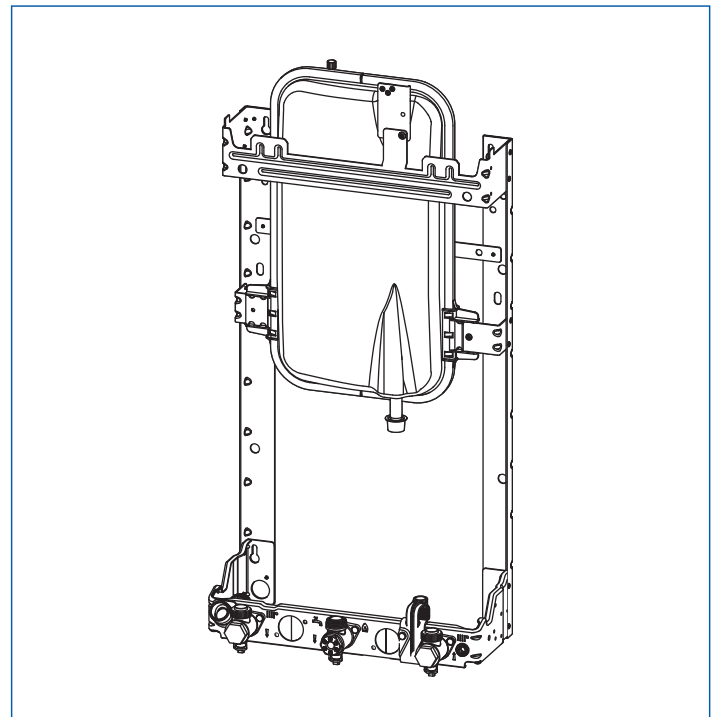

Greenstar 27i & 30i System boiler wall-mounting jig

Casing dimensions

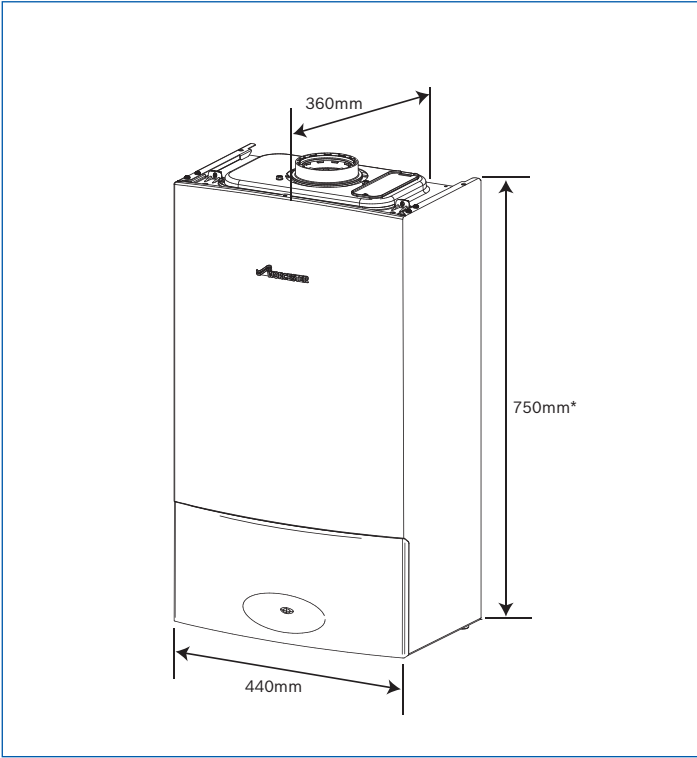

Greenstar CDi Classic System
*760mm to top of casing front.

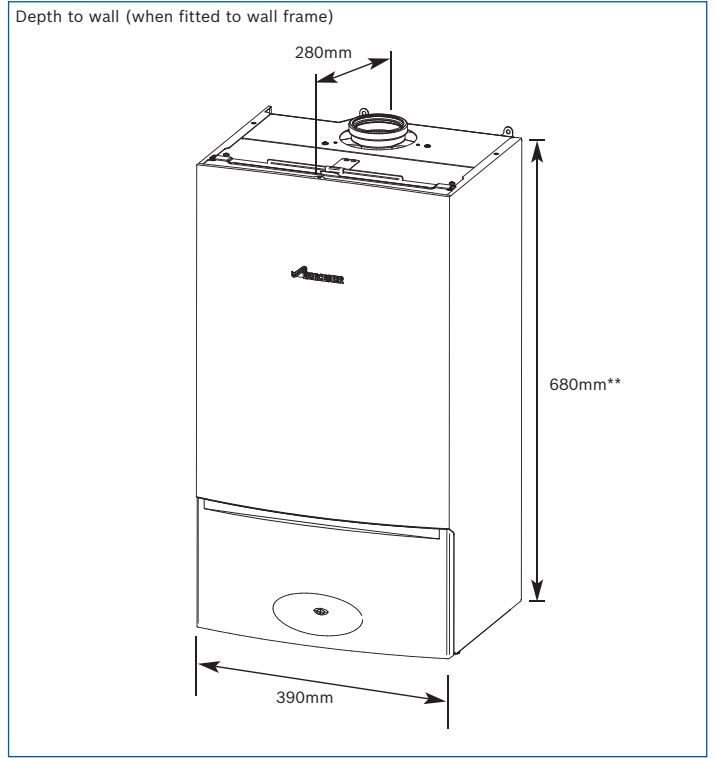

Greenstar 27i & 30i System
**690mm to top of casing front.

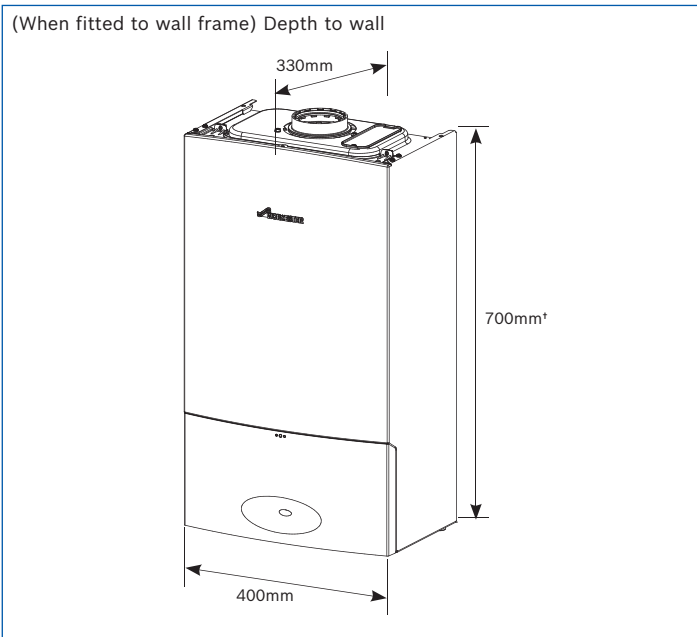

Greenstar 12i-24i System
*710mm to top of casing front.

Pipework connections

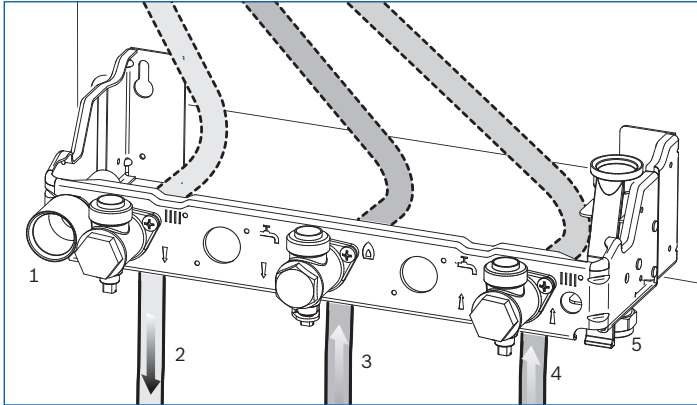

Greenstar CDi Classic System

Pipework connections – Greenstar CDi Classic System			
	Function	From left case edge	Diameter of pipe
1	Condensate drain	55mm	22mm
2	CH flow	85mm	22mm
3	Gas	212mm	22mm
4	CH return	343mm	22mm
5	Pressure relief valve	375mm	15mm

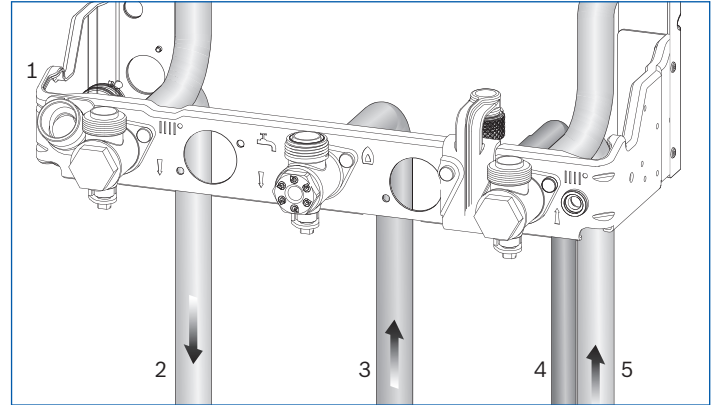

Greenstar 27i & 30i System

Pipework connections – Greenstar 27i & 30i System			
	Function	From left case edge	Diameter of pipe
1	Condensate drain	33mm	22mm
2	CH flow	65mm	22mm
3	Gas	195mm	22mm
4	Pressure relief valve	291mm	15mm
5	CH return	325mm	22mm

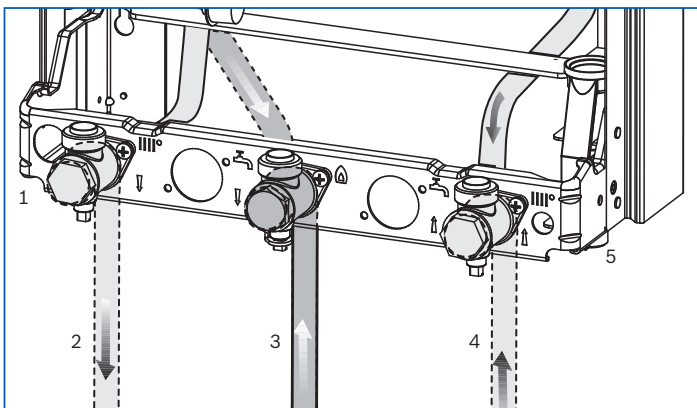

Greenstar 12i-24i System

Pipework connections – Greenstar 12i-24i System			
	Function	From left case edge	Diameter of pipe
1	Condensate drain	35mm	22mm
2	CH flow	70mm	22mm
3	Gas	200mm	22mm
4	CH return	330mm	22mm
5	Pressure relief valve	367mm	15mm

Optional accessory

The vertical pre-piping assembly kit (CDi Classic System 7 716 192 651, i System (12-24kW) 7 716 192 650, i System (27 & 30kW) 7 716 192 713) comprises a set of pre-formed copper pipes and an electrical cross-bonding strip*.

*The electrical cross bonding strip comes as standard with the CDi Classic System range and therefore is not included in the pre-piping kit 7 716 192 651.

Installation requirements

Installation of the Greenstar system boiler range must be in accordance with the relevant requirements of the Gas Safety (Installation Use) Regulations (as amended), current IEE Wiring Regulations, local Building Regulations, Building Standards (Scotland) regulations and bylaws of the local water company and Health and Safety Document No. 635 (Electricity at Work Regulations 1989). It should be in accordance with the relevant recommendations of the following British Standards:

BS 6798; BS 5449; BS 5546:1; BS 5440:1; BS 5440:2; BS 6891.

Gas Safety (Installation and Use) Regulations. All gas appliances must be installed by a Gas Safe registered person in accordance with the above regulations. Failure to install appliances correctly could lead to prosecution.

The manufacturer's notes must not be taken in any way as overriding statutory regulations.

Sealed primary systems

Worcester Greenstar System boilers are supplied complete with all the necessary components to form a sealed primary system. Included are an expansion vessel, a pressure relief valve (set at 3bar), an automatic air vent and a pressure gauge.

With an initial system pressure of 0.5bar a system capacity of approximately 83 litres can be accommodated. Refer to BS 7074:Part 1 for more information.

It is important with an aluminium heat exchanger that the pH level of the water does not exceed 8. Levels in excess of this could be detrimental to the heat exchanger.

The use of a suitable inhibitor will provide a resistance to this. Contact Sentinel (Tel: 0800 3894670 or visit www.sentinel-solutions.net) or Fernox (Tel: 0870 601 5000 or visit www.fernox.com) for further details.

Greenstar system boilers are fitted with a manual reset button and are suitable for use with a sealed primary system.

The system should be installed in compliance with the requirements of BS 5449: Part 1.

Manual air vents should be fitted at any high points in the system.

System filling and make-up

To comply with the Water Authority requirements, the system should be filled via a temporary hose connection to the mains cold water supply, with a double check valve assembly and test point fitted to the mains water side of a temporary circuit.

Valves and joints

It is very important that all valves and joints are able to sustain a working pressure of up to 3bar (45psi). Particular care should be exercised when fitting radiator valves and only those of high quality to BS 2767:10 should be used. All other valves and fittings should comply with BS 1010.

Loss of water pressure from a sealed system will require continuous recharging with fresh water and consequential introduction of air. Air is highly corrosive and will considerably reduce life-expectancy of radiators, pumps etc.

Greenstar system boiler diverter valve kit

Greenstar system boilers can be adapted to house an in-built diverter valve. The optional integral diverter valve kit allows the user to control the supply of heat to the hot water cylinder from the boiler. A choice of Worcester plug-in controls must be used.

Plastic pipework

The use of plastic pipework is acceptable. However, some plastics are permeable to oxygen and must be avoided. Only pipework with a polymeric barrier should be used. Please note that the first 600mm of pipework connected to the boiler must be of copper or steel.

Air supply

Worcester Greenstar system boilers are room-sealed appliances; the room in which it is installed does not therefore require a purpose-provided combustion air vent.

Natural gas supply

Gas supply pipework must be sized to ensure a maximum 1mbar pressure drop between the meter and appliance inlet, +1.5mbar across the appliance to the gas valve test point.

Listed below is a representative example. Figures for other appliances can be found in the relevant installation manuals.

Model	Gas rate
30CDi Classic System	3.2m ³ /hr
30i System	3.24m ³ /hr
24i System	2.67m ³ /hr

The gas meter and supply pipes must be capable of supplying this quantity of gas in addition to the demand from any other appliance being served. Particular consideration should be given to the resistance to gas flow created by elbows, bends etc.

Greenstar 12, 15, 18 and 24i System models

Provided that the correct gas supply working pressure and gas rate can be achieved (refer to BS 6891) then it may be possible to reduce the gas supply pipe diameter to 15mm.

Generally speaking, the appliance would need to be within 3 to 4 metres of the gas meter. However, this will depend on the distribution pipe size and route.

Liquid Petroleum Gas (LPG) supply

Listed below is a representative example. Figures for other appliances can be found in the relevant installation manuals.

Model	Gas rate
30CDi Classic System	2.4kg/hr
30i System	2.33kg/hr
24i System	1.91kg/hr

The gas tank or bottles must be capable of supplying this quantity of gas at a nominal pressure of 37mbar (14.8in wg) at the appliance.

Electricity supply

A 3amp fused three pin plug and unswitched shuttered socket outlet (both complying with BS 1362) or preferably a double pole isolator with a contact separation of 3mm in all poles supplying the appliance should be used.

The Greenstar CDi Classic System and Greenstar 12-24i System boilers' electrical circuits are also protected by an internal 2.5amp fuse, while the Greenstar 27i and 30i System models use a 5amp fuse. The appliance must be earthed.

Guarantee

Worcester Greenstar system appliances are offered with a full 5 year guarantee* on parts and labour and a 10 year guarantee* on the primary heat exchanger*. Ongoing service and maintenance contracts can be arranged through the Worcester Customer Service Department.

Please contact our guarantee registration advisors on 0330 123 2552 or visit www.worcester-bosch.co.uk/guarantee



On all Greenstar system appliances*



On the primary heat exchanger*

The Worcester Greenstar System Filter

Modern condensing boilers are precision-engineered and designed to run with a clean water heating system. Over time, dirty system water will damage a boiler and its components, causing failures and shortening the life of the overall system.

Damaged boiler and system components

- Blockages in primary heat exchanger
- Increased wear on pumps
- Blocked valves.

Reduced efficiency

- Energy efficiency loss equivalent to a boiler being reduced from A rated efficiency to D rated, resulting in fuel wastage
- Blocked radiators can reduce efficiency and heating comfort.

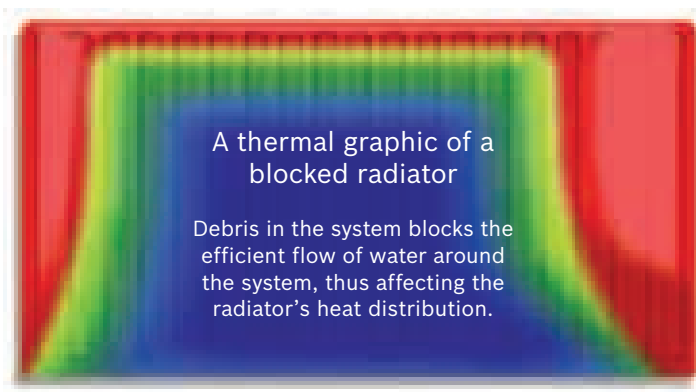

A highly effective solution from the brand you can trust

The Worcester Greenstar System Filter has been specifically designed to combat the damaging effects of system debris and pollutants, allowing homeowners to protect their boiler or heat pump for a fraction of its cost. The filter is suitable for 22mm piped heating systems.

At the centre of this innovative design is a highly powerful magnet that removes the magnetic debris (magnetite) that is present in the heating system water. The central location of the magnet ensures that magnetite is collected quickly and retained, maximising the overall protection. Any non-magnetic debris is caught by the twin-action cyclonic trap, a proven technology that offers a capacity to collect up to 200g of magnetite a year.



The Greenstar System Filter has been extensively tested in simulated systems, proving its effectiveness in removing iron oxide, magnetite, limescale particles, casting sand, welding debris, non-magnetic metal flakes, paint particles and other system pollutants.

How the Greenstar System Filter removes debris from the system water.

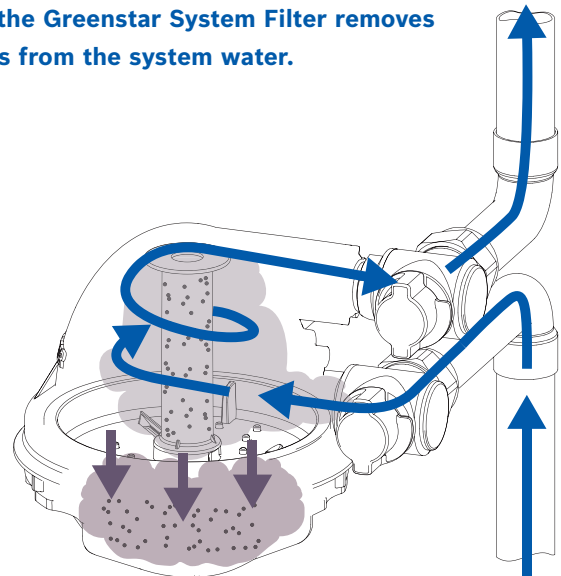

Installation

The filter can be installed almost anywhere in a heating system, however to maximise the effectiveness, it should be placed before the boiler and after the last radiator on the return pipework.



Features	Benefits
Highly effective filter	Safeguards the boiler against damage and protects the efficiency of the system. Saves up to 6% a year on energy bills*
Prevent blockages in radiators	A warmer home and quieter system
High powered internal magnet	Proven technology that can capture up to 200g of magnetite
Cylindrical design	Increased performance – better installation options
Twin-action – magnetic and non-magnetic filtration	Instantly effective against a wide range of system debris
No power consumption or moving parts	No electrical wiring connection or supply needed. Zero running costs and no failure of components
Can be installed under the boiler or away from the appliance	Flexibility
One-way valve for adding system chemicals	Removes the need to isolate a section of the system when carrying out servicing and maintenance
Worcester, Bosch Group specification and design	Reliability of components and filter

*Independent research carried out by GASTEC at CRE

Product info	
Part number	7 716 192 609

Condensate pipework

Important points to consider when siting a condensate drainage pipe:

- **Where a new or replacement boiler is being installed, access to an internal “gravity discharge” point should be one of the factors considered in determining boiler location**
- **The condensate pipe must be a minimum of 22mm dia. plastic pipe**
- **The condensate pipework must fall at least 52mm per metre towards the outlet and should take the shortest practicable route**
- **Ensure there are no blockages in the pipe run.**

Internal connections

In order to minimise the risk of freezing during prolonged cold spells, the following methods of installing a condensate drainage pipe should be adopted, **in order of priority**.

Wherever possible, the condensate drainage pipe should be routed and terminated so that the condensate drains away from the boiler, under gravity, to a suitable internal foul water discharge point, such as an internal soil and vent stack. A suitable permanent connection to the foul waste pipe should be used. (see fig. 1)

Alternatively, if the first option is not possible, an internal kitchen, bathroom or washing machine waste pipe etc. can be used. (see fig. 2)

Condensate pump

Where “gravity discharge” to an internal termination is not physically possible, or where very long internal runs would be required to reach a suitable discharge point, condensate should be removed using a proprietary condensate pump of a specification recommended by the boiler or condensate pump manufacturer.

The pump outlet pipe should discharge to a suitable internal foul water discharge point such as an internal soil and vent stack, internal kitchen, bathroom or washing machine waste pipe, etc. A suitable permanent connection to the foul waste pipe should be used. (see fig. 3)

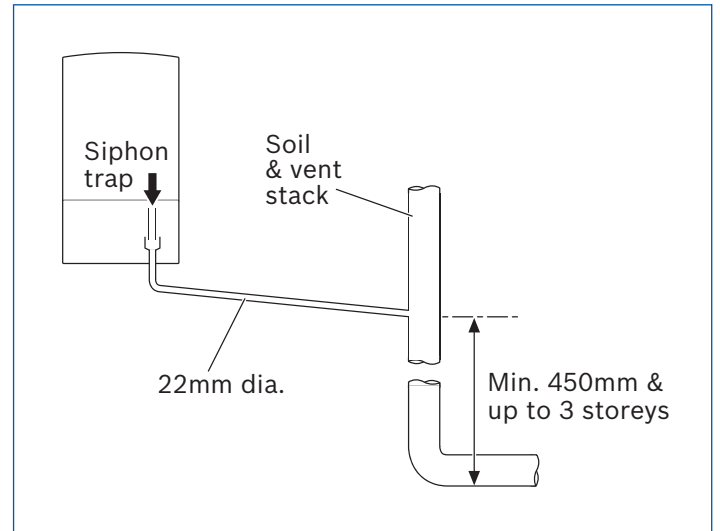

Fig. 1 Disposal to soil vent stack

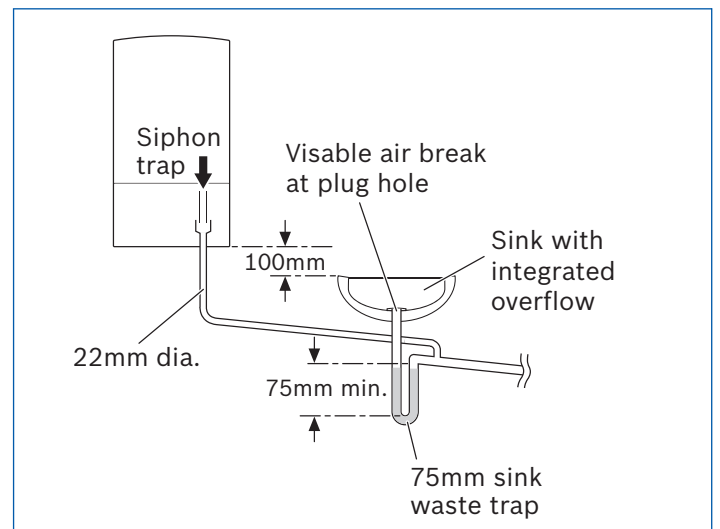

Fig. 2 Disposal to a waste pipe

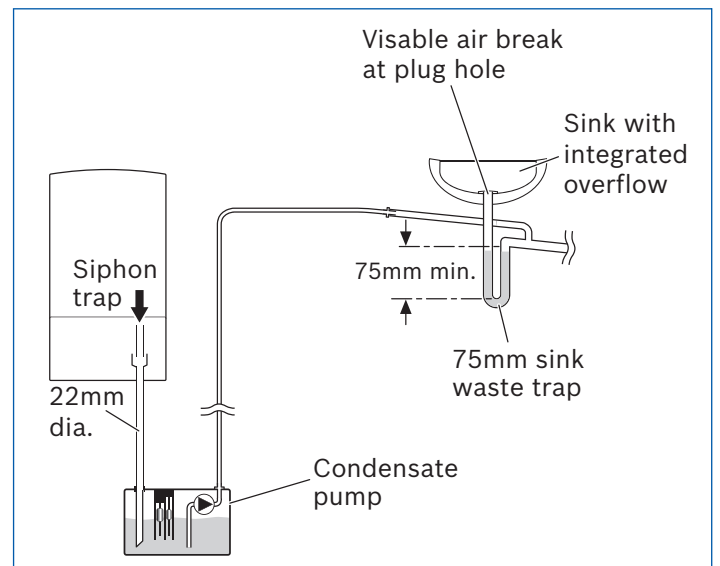

Fig. 3 Condensate pump disposal

External connections

Freezing conditions

- When the position of the boiler prevents internal routing, we recommend installing a Worcester CondenseSure siphon to minimise the risk of freezing
- Pipework length should be kept to a minimum and the route as vertical as possible
- Weather-proofing insulation must be sized when not using a CondenseSure siphon.

Condensate waste

- Care should be taken when siting a soak away to avoid obstructing existing services.

If no other discharge method is possible, then the use of an externally-run condensate drainage pipe terminating at a suitable foul water discharge point (fig. 4), or purpose-designed soak away (fig. 6), may be considered. Please see installation and servicing instructions for more details.

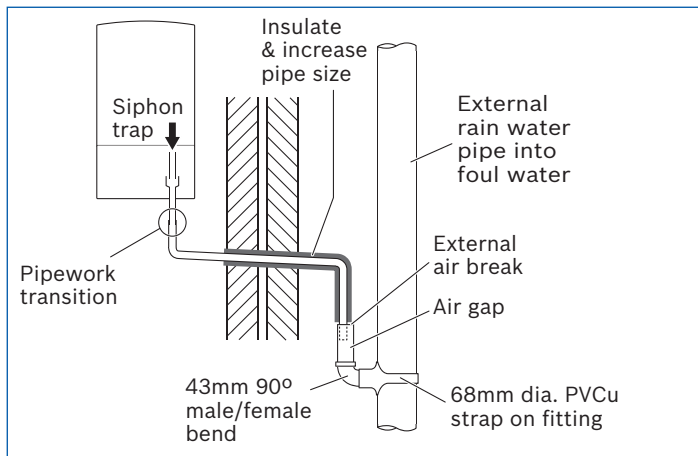

Fig. 4 Disposal into a rainwater down pipe

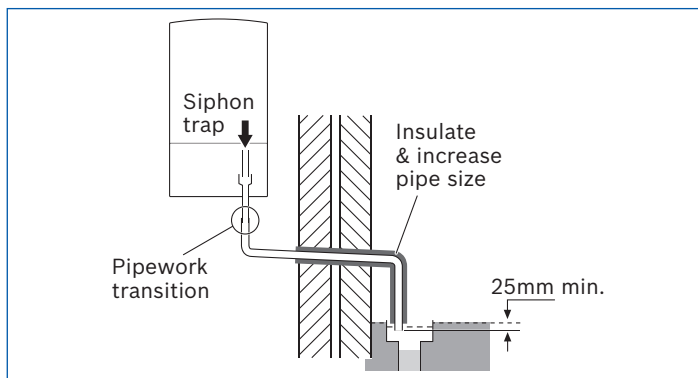

Fig. 5 External disposal

Condensate soak away (see fig. 6)

- The condensate drainage pipe may be run above or below the ground to the soak away
- The examples shown run above ground
- The soak away must use a 100mm dia. plastic tube with two rows of three 12mm holes on 25mm centres and 50mm from the bottom of the tube. The holes must face away from the house
- The tube must be surrounded by at least 100mm of limestone chippings to a depth of 400mm
- Minimum hole size for the condensate soak away must be 400mm deep by 300mm dia.

In situations where there are likely to be extremes of temperature or exposure, the use of a proprietary trace heating system for external pipework (that incorporates an external frost thermostat) should be considered. If such a system is used, the requirement to use 32mm pipe does not apply, however all other guidance above, and the instructions for the trace heating system, should be closely followed.

Unheated internal areas

Internal pipe runs in unheated areas such as lofts, basements and garages should be treated as external runs, with consideration given to using a CondenseSure siphon.

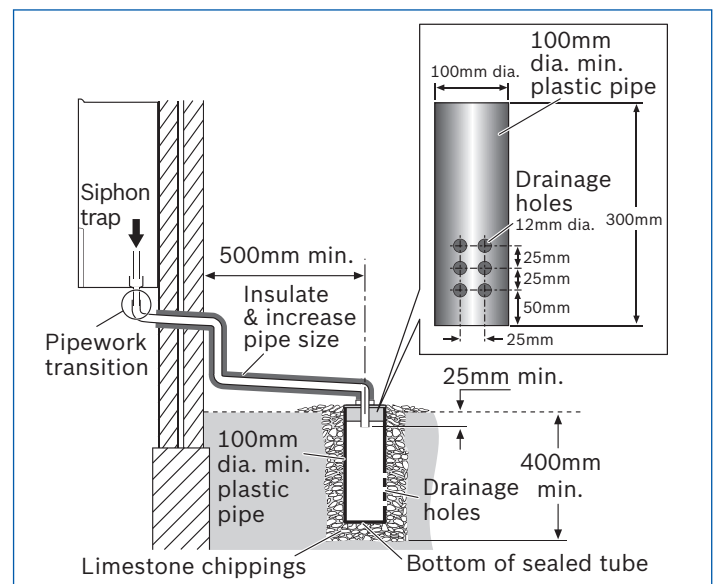

Fig. 6 Soak away

In addition to the condensate discharge options illustrated on these pages and in the Installation, Commissioning and Servicing Instruction Manual, the new Worcester CondenseSure auxiliary siphon provides an innovative alternative for the prevention of freezing for externally-run discharge condensate (see over for details).

For full technical information on pipe size, insulation and different condensate pipework methods, please see Installation, Commissioning and Servicing Instruction Manual.

The Worcester CondenseSure

With climate change and extreme weather variations becoming increasingly common, and very cold winters with temperatures as low as -20°C being experienced, practices such as externally-run condensate discharge pipework are now being questioned.

The CondenseSure auxiliary siphon has been designed to allow a more flexible approach to boiler siting.

Tested to extreme temperatures

The CondenseSure has been extensively tested under simulated extreme weather conditions and proved its effectiveness in preventing frozen condensate at -15°C for a sustained period of 48 hours.

CondenseSure principle of operation

Within most condensing boilers, there is an internal siphon which holds around 100ml of condensate before being released down the condensate discharge pipe. A typical high-efficiency condensing boiler will generate up to 2 litres of condensate an hour (dependant on output and temperature) and this will result in the in-built siphon discharging approximately every 3 minutes. With this frequency of discharge, it is unlikely that the condensate pipework is ever empty of condensate, consequently increasing the potential for freezing of the pipework in prolonged sub-zero temperatures.

The CondenseSure siphon connects to the boiler condensate discharge outlet and collects the condensate into a larger volume before releasing it into the discharge pipe.

With this expanded siphonic operation, the discharge from the CondenseSure is every 15 to 20 minutes, resulting in:

- Increased velocity and flow rate
- With only 3 to 4 siphonic actions per hour, the condensate pipework is empty for longer
- Significantly decreased or even eliminated freezing potential.



The CondenseSure insulating jacket helps to retain the temperature of the condensate.

A universal fitting for new and existing installations

Although developed specifically for Worcester Greenstar gas- and oil-fired boilers, the Worcester CondenseSure can also be fitted to any make of condensing boiler for both new and retrofit installations. The CondenseSure can provide a simple solution which eliminates the need for re-siting both the new boiler and the system pipework when replacing an existing non-condensing appliance. The CondenseSure can easily be fitted to existing installations to provide peace of mind in extreme weather conditions.

Features	Benefits
No power consumption	No electrical wiring connection or supply needed, meaning zero running costs
No moving parts	No failure of components
Can be installed on new or existing installations	Suitable for any gas- or oil-fired condensing boilers
Can be attached to 22mm heating flow pipework	Uses 'free' energy from the pipe to heat the condensate
Under boiler or remote installation	Flexibility
No electrical connections	No electrician needed
No pipe insulation needed	Cost-saving and aesthetically pleasing

Ease of installation

The CondenseSure has been designed with ease of installation in mind and is suitable for most boiler applications. For maximum effectiveness, it should be installed immediately beneath the boiler where it is clipped on to the boiler's heating flow pipe and connected to its siphonic trap. If this is not practical, the CondenseSure can be wall-mounted away from the boiler and connected to a 32mm condensate discharge pipe. However, this will sacrifice the benefit of warming the condensate prior to discharge and therefore slightly reduce its performance.

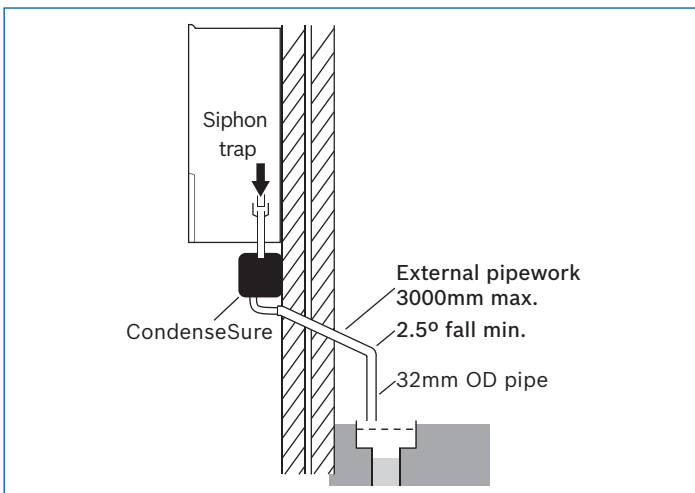

A typical installation using CondenseSure

The CondenseSure installation parameters

The CondenseSure will protect an externally-run condensate discharge pipe from freezing for 48 hours at -15°C providing the following installation parameters are met:

- The externally-run pipe length does not exceed 3 metres
- There is a fall on the discharge pipe of at least 2.5 degrees
- The discharge pipe diameter is not less than 32mm in diameter.

Whilst it is not necessary to insulate the pipework, it may be a consideration if longer lengths or if lower external temperatures are expected.



The CondenseSure clips onto the 22mm heating flow pipe using the 'free' heat to raise the condensate temperature.

Fitting to a system boiler

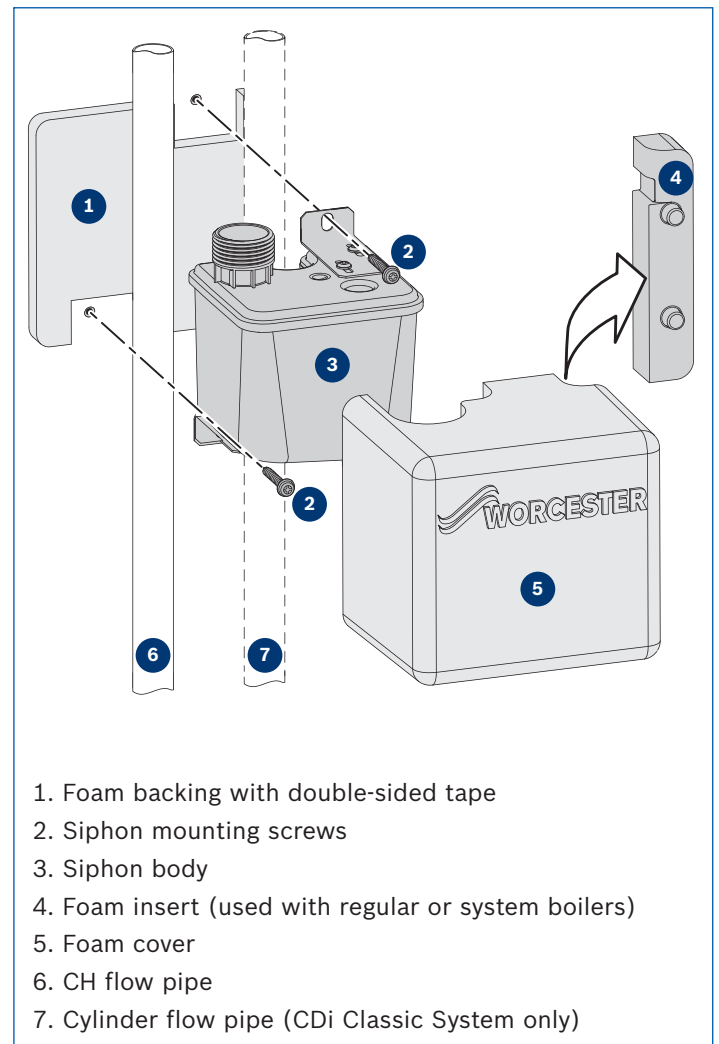

1. Foam backing with double-sided tape
2. Siphon mounting screws
3. Siphon body
4. Foam insert (used with regular or system boilers)
5. Foam cover
6. CH flow pipe
7. Cylinder flow pipe (CDi Classic System only)

Additional installation considerations include:

- Keeping any external pipework as short as possible
- Minimising the number of bends and connections
- Removal of burrs after cutting pipe
- Removal of surplus solvent from the interior of the pipe.

The CondenseSure has no working parts to breakdown, does not use any energy and has no electrical connections, so there is no Part P requirement.

Product info

Part number	7 716 192 746
-------------	---------------

Horizontal and vertical flue terminal positioning

All measurements in millimetres

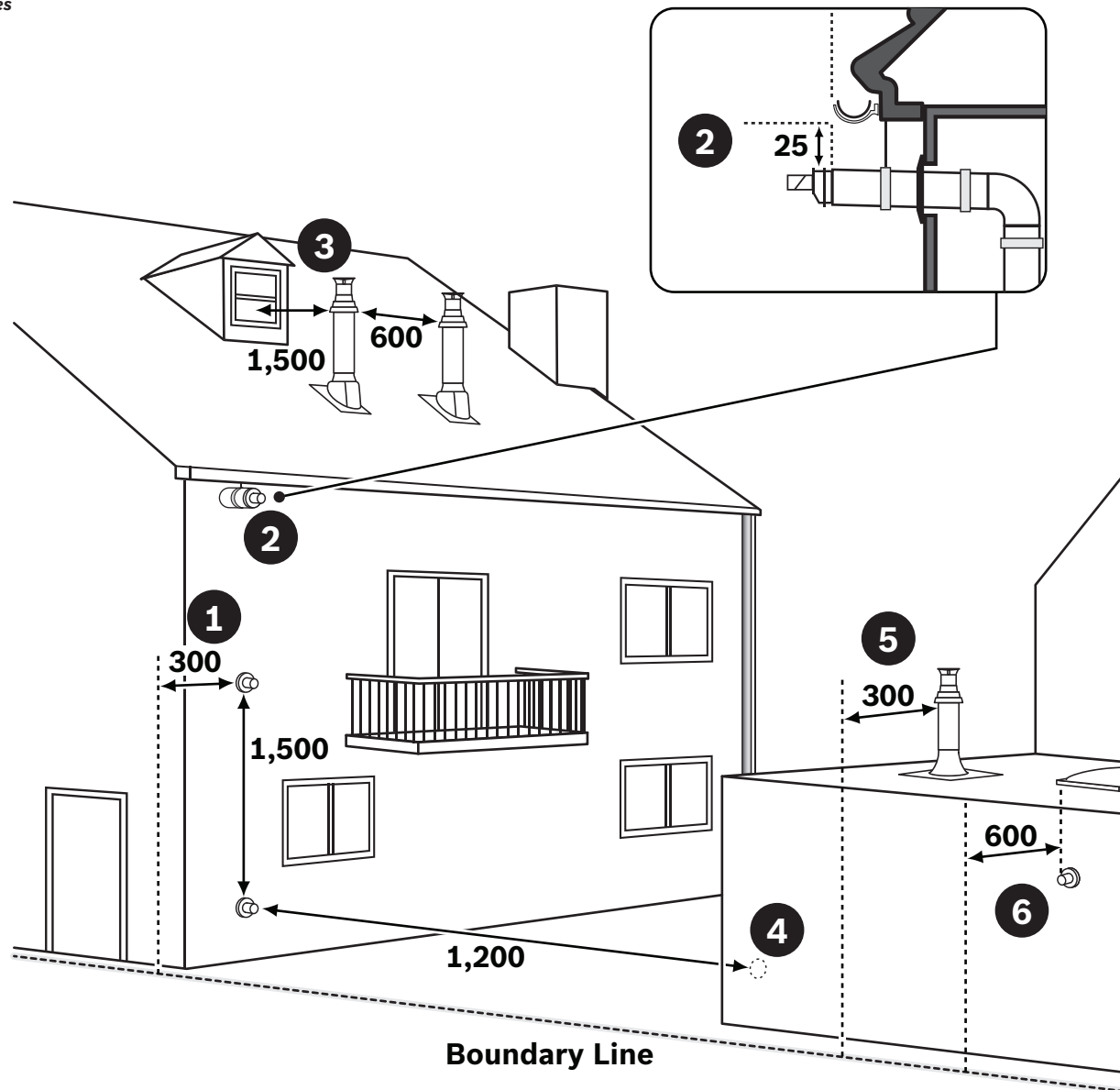

Note

- All measurements are the minimum clearances required
- Terminals must be positioned so as to avoid combustion products entering the building
- Support the flue at approximately one metre intervals and at a change of direction, use suitable brackets and fittings.

Flue bracket part numbers:

7 716 191 092 (100mm dia.)

7 716 191 173 (100mm dia. x 6)

7 716 191 174 (125mm dia.)

7 716 191 177 (100mm dia.) – 27i & 30i System only

7 716 191 178 (100mm dia. x 6) – 27i & 30i System only

7 716 191 179 (125mm dia.) – 27i & 30i System only

Key to illustration

1. 300mm adjacent to a boundary line.
2. The dimension below eaves, balconies and car ports can be reduced to 25mm, as long as the flue terminal is extended to clear any overhang. External flue joints must be sealed with suitable silicon sealant.
3. 1,500mm between a vertical flue terminal and a window or dormer window.
4. 1,200mm between terminals facing each other.
5. Vertical flue clearance, 300mm adjacent to a boundary line.
6. 600mm distance to a boundary line, unless it will cause a nuisance. BS 5440:Part 1 recommends that care is taken when siting terminal in relation to boundary lines.
7. 600mm minimum clearance from a skylight to a vertical flue.
8. Vertical flue clearance, 500mm to non-combustible building material, and 1,500mm clearance to combustible building material.

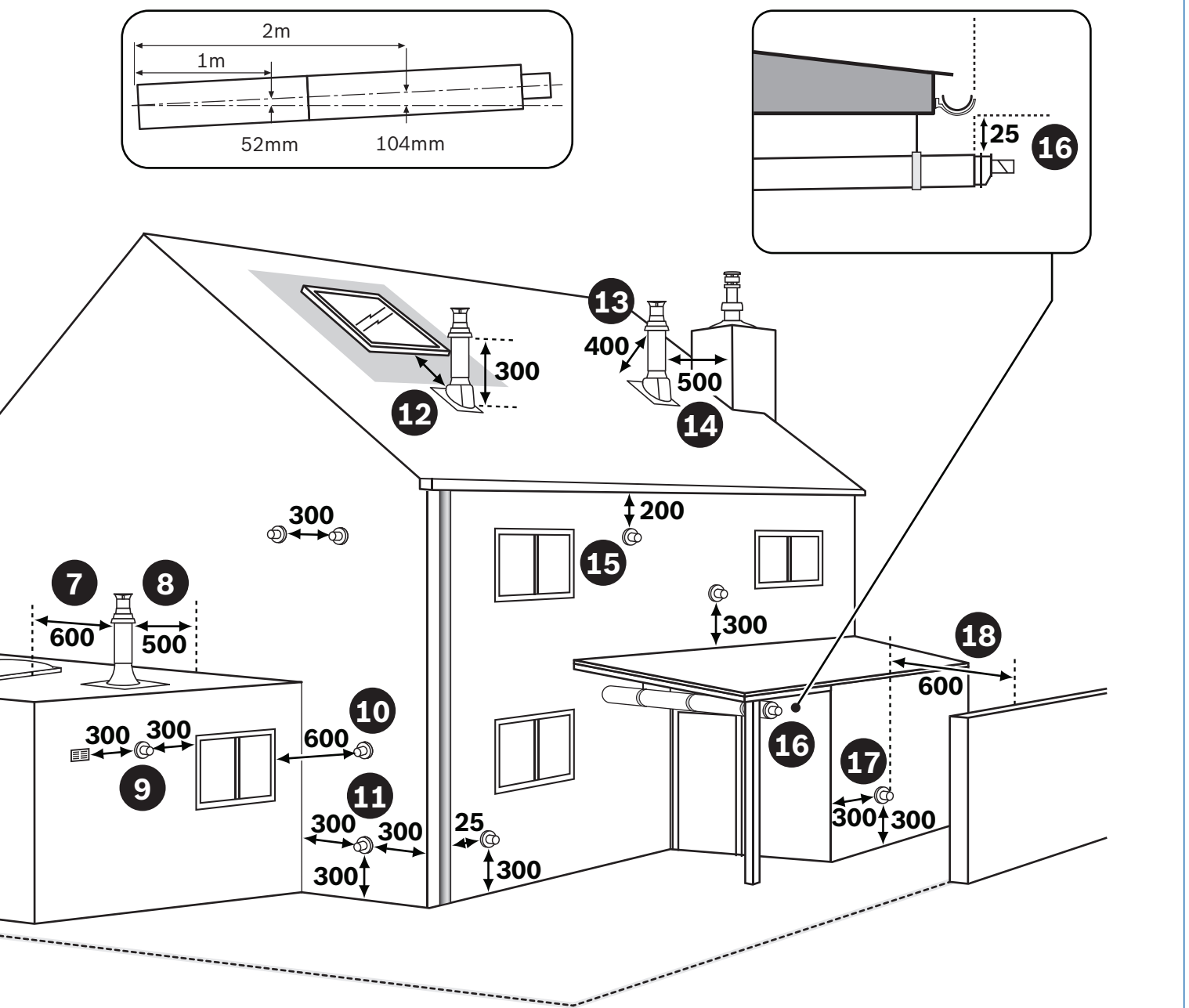

9. 300mm above, below and either side of an opening door, air vent or opening window.
 10. 600mm diagonally to an opening door, air vent or opening window.
 11. 300mm to an internal or external corner.
 12. 2,000mm below a Velux window, 600mm above or to either side of the Velux window.
 13. 400mm from a pitched roof or 500mm in regions with heavy snowfall.
 14. 500mm clearance to any vertical structure on a roof, 600mm to room sealed flue or 1,500 to an open flue.
 15. 200mm below eaves and 75mm below gutters, pipe and drains.
 16. The dimension below eaves, balconies and car ports can be reduced to 25mm, as long as the flue terminal is extended to clear any overhang. External flue joints must be sealed with suitable silicon sealant.
 17. Flue clearance must be at least 300mm from the ground. Terminal guards must be fitted if the flue is less than 2 metres from the ground or if a person could come into contact with the flue terminal.
 18. 600mm distance to a surface facing a terminal, unless it will cause a nuisance. BS 5440: Part 1 recommends that care is taken when siting terminals in relation to surfaces facing a terminal.
- **Installations in car ports are not recommended**
 - **The flue cannot be lower than 1,000mm from the top of a light well due to the build-up of combustion products**
 - **Dimensions from a flue terminal to a fanned air inlet to be determined by the ventilation equipment manufacturer.**

Greenstar system boiler range horizontal fluing options

The Greenstar system boiler range offers the choice of 2 differently sized horizontal RSF flue systems, a 100mm diameter telescopic flue kit including a plume management kit, and a 125mm diameter telescopic flue kit. Both systems have different maximum lengths. The following diagrams detail the permissible lengths.

Horizontal RS flue



Flue diameter	100mm	125mm
Greenstar 30CDi Classic System model		
Minimum flue length	350mm*	405mm
Maximum flue length	7,900mm	18,500mm
Greenstar 35CDi Classic System model		
Minimum flue length	30mm	30mm
Maximum flue length	7,000mm	16,000mm
Greenstar 12i-24i System models		
Minimum flue length	350mm*	405mm
Maximum flue length	4,600mm	13,000mm
Greenstar 27i & 30i System models		
Minimum flue length	350mm*	405mm
Maximum flue length	6,000mm	15,000mm

*Can be cut to 130mm. Please refer to instructions.

100mm dia. standard telescopic flue kit

- 1 x flue turret elbow
- 570mm (100mm dia.) of flue duct
- 1 x weather sealing ring
- 1 x internal collar

Part No. 7 716 191 082

125mm dia. standard telescopic flue kit

- 1 x flue turret elbow
- 600mm (125mm dia.) of flue duct including terminal (as measured from centre of flue outlet)
- 1 x weather sealing plate
- 1 x internal plate

Part No. 7 719 003 702

Accessories



Components	Part No.	Description
100mm diameter		
	7 716 191 082	Standard telescopic flue kit (350 - 570mm)
	7 716 191 171	Long telescopic flue kit (570 - 790mm)
	7 716 191 083	Extension flue kit (960mm*)
	7 716 191 172	2m flue extension*
	7 716 191 133	Short flue extension (220mm*)
	7 716 191 084	90° bend
	7 716 191 085	45° bend
	7 719 002 432	High level horizontal flue adaptor
	7 716 191 092	Support bracket kit
	7 716 191 173	Support bracket kit (6 pack)
	7 716 191 177	Support bracket kit (27i & 30i System)
	7 716 191 178	Support bracket kit (6 pack) (27i & 30i System)

*Dimensions when fitted

125mm diameter		
	7 719 003 702	Standard telescopic flue kit (405 - 600mm)
	7 719 003 666	Extension flue kit (960mm*)
	7 719 003 664	90° bend
	7 719 003 665	45° bend
	7 719 002 433	High level horizontal flue adaptor
	7 716 191 174	Support bracket kit
	7 716 191 179	Support bracket kit (27i & 30i System)

*Dimensions when fitted

The following criteria should be noted when planning the installation:

- The concentric flue system must be inclined at 3° (52mm per metre) from the appliance, to allow condensate to drain back into the boiler
- A white plume of condensation will be emitted from the terminal because the appliance operates at high efficiency. Care must be taken when selecting the flue terminal position
- To achieve a maximum flue length, one of the extension flue kits will need to be cut so that the permitted maximum flue length is not exceeded
- Horizontal flue options 1-6 illustrate common flue installations. Other configurations of the flue system are possible up to, and not exceeding, the stated maximum flue lengths.

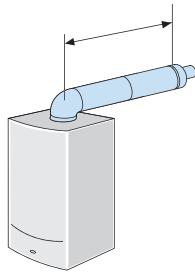

Option 1: Standard horizontal flue assembly

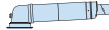

Components		
Part No. 100mm		7 716 191 082
Part No. 125mm		7 719 003 702
Maximum lengths (mm) & no. of components required		
Greenstar 30CDi Classic System		
100mm	570	1
125mm	600	1
Greenstar 35CDi Classic System		
100mm	30	1
125mm	30	1
Greenstar 12i-24i System		
100mm	570	1
125mm	600	1
Greenstar 27i & 30i System		
100mm	570	1
125mm	600	1

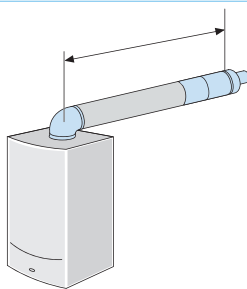

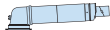
Option 2: Extension flue horizontal

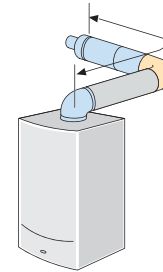

Components			
Part No. 100mm		7 716 191 082	7 716 191 083
Part No. 125mm		7 719 003 702	7 719 003 666
Maximum lengths (mm) & no. of components required			
Greenstar 30CDi Classic System			
100mm	7,900	1	up to 8
125mm	18,500	1	up to 18
Greenstar 35CDi Classic System			
100mm	7,000	1	up to 7
125mm	16,000	1	up to 16
Greenstar 12i-24i System			
100mm	4,600	1	up to 5
125mm	13,000	1	up to 13
Greenstar 27i & 30i System			
100mm	6,000	1	up to 6
125mm	15,000	1	up to 15

Option 3: Extension flue horizontal using a second 90° bend



Components				
Part No. 100mm		7 716 191 082	7 716 191 083	7 716 191 084
Part No. 125mm		7 719 003 702	7 719 003 666	7 719 003 664
Maximum lengths (mm) & no. of components required				
Greenstar 30CDi Classic System				
100mm	6,400	1	up to 6	1
125mm	16,500	1	up to 16	1
Greenstar 35CDi Classic System				
100mm	5,500	1	up to 6	1
125mm	14,000	1	up to 14	1
Greenstar 12i-24i System				
100mm	2,600	1	up to 3	1
125mm	11,000	1	up to 11	1
Greenstar 27i & 30i System				
100mm	4,000	1	up to 4	1
125mm	13,000	1	up to 13	1

Note: The 100mm dia. short flue extension (Part No. 7 716 191 133) and 100mm dia. 2m flue extension (Part No. 7 716 191 172) may be used as an alternative to the standard extension as required up to the maximum flue lengths stated.

Note: The maximum flue length must be reduced by the following amounts for each bend used.

	45° bend	90° bend
Greenstar CDi Classic System 60/100mm flues	750mm	1,500mm
Greenstar CDi Classic System 80/125mm flues	1,000mm	2,000mm
Greenstar i System – all size flues	1,000mm	2,000mm

Option 4: Extension flue horizontal and upwards

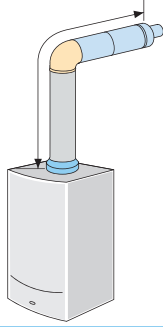

Components					
Part No. 100mm	7 716 191 082	7 716 191 083	7 716 191 084	7 719 002 432	
Part No. 125mm	7 719 003 702	7 719 003 666	7 719 003 664	7 719 002 433	
Maximum lengths (mm) & no. of components required					
Greenstar 30CDi Classic System					
100mm	7,900	1	up to 8	1	1
125mm	18,500	1	up to 18	1	1
Greenstar 35CDi Classic System					
100mm	7,000	1	up to 7	1	1
125mm	16,000	1	up to 16	1	1
Greenstar 12i-24i System					
100mm	4,600	1	up to 5	1	1
125mm	13,000	1	up to 13	1	1
Greenstar 27i & 30i System					
100mm	6,000	1	up to 6	1	1
125mm	15,000	1	up to 15	1	1

Option 5: Extension flue upwards and horizontal using a second 90° bend

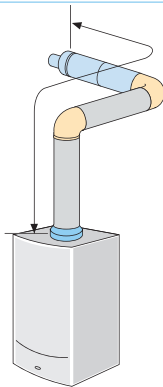

Components					
Part No. 100mm	7 716 191 082	7 716 191 083	7 716 191 084	7 719 002 432	
Part No. 125mm	7 719 003 702	7 719 003 666	7 719 003 664	7 719 002 433	
Maximum lengths (mm) & no. of components required					
Greenstar 30CDi Classic System					
100mm	6,400	1	up to 7	2	1
125mm	16,500	1	up to 16	2	1
Greenstar 35CDi Classic System					
100mm	5,500	1	up to 6	2	1
125mm	14,000	1	up to 14	2	1
Greenstar 12i-24i System					
100mm	2,600	1	up to 2	2	1
125mm	11,000	1	up to 11	2	1
Greenstar 27i & 30i System					
100mm	4,000	1	up to 4	2	1
125mm	13,000	1	up to 13	2	1

Option 6: Extension flue upwards and horizontal using a third 90° bend

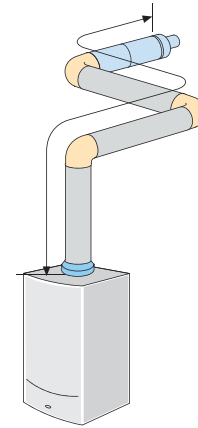

Components					
Part No. 100mm	7 716 191 082	7 716 191 083	7 716 191 084	7 719 002 432	
Part No. 125mm	7 719 003 702	7 719 003 666	7 719 003 664	7 719 002 433	
Maximum lengths (mm) & no. of components required					
Greenstar 30CDi Classic System					
100mm	4,900	1	up to 5	3	1
125mm	14,500	1	up to 14	3	1
Greenstar 35CDi Classic System					
100mm	4,000	1	up to 4	3	1
125mm	12,000	1	up to 12	3	1
Greenstar 12i-24i System					
125mm	9,000	1	up to 9	3	1
Greenstar 27i & 30i System					
100mm	2,000	1	up to 2	3	1
125mm	11,000	1	up to 11	3	1

45° options available

Note: The 100mm dia. short flue extension (Part No. 7 716 191 133) and 100mm dia. 2m flue extension (Part No. 7 716 191 172) may be used as an alternative to the standard extension as required up to the maximum flue lengths stated.

Note: The maximum flue length must be reduced by the following amounts for each bend used.

	45° bend	90° bend
Greenstar CDi Classic System 60/100mm flues	750mm	1,500mm
Greenstar CDi Classic System 80/125mm flues	1,000mm	2,000mm
Greenstar i System – all size flues	1,000mm	2,000mm

Greenstar system boiler range vertical fluing options

The Greenstar system boiler range offers the choice of 2 differently sized vertical RSF flue systems, 100mm and 125mm. Both systems have different maximum lengths. The following diagrams detail the permissible lengths.

Vertical RSF flue



Flue diameter	100mm	125mm
Greenstar 30CDi & 35CDi Classic System		
Minimum flue length	1,090mm	1,365mm
Maximum flue length (inc. adaptor)	9,400mm	18,500mm
Greenstar 12i-24i System models		
Minimum flue length	1,090mm	1,365mm
Maximum flue length (inc. adaptor)	6,400mm	15,000mm
Greenstar 27i & 30i System models		
Minimum flue length	1,090mm	1,365mm
Maximum flue length (inc. adaptor)	6,000mm	15,000mm

100mm dia. vertical balanced flue kit

- 1 x flue terminal assembly
- 1 x weather sealing collar
- 1 x fire stop spacer
- 1 x vertical adaptor

Part No. 7 719 002 430

125mm dia. vertical balanced flue kit

- 1 x flue terminal assembly
- 1 x weather sealing collar
- 1 x fire stop spacer
- 1 x vertical adaptor

Part No. 7 719 002 431

Accessories



Components	Part No.	Description
100mm diameter		
	7 719 002 430	Vertical 1,090mm balanced flue kit (inc. adaptor)
	7 716 191 083	Extension flue kit (960mm*)
	7 716 191 172	2m flue extension*
	7 716 191 133	Short flue extension (220mm*)
	7 716 191 084	90° bend
	7 716 191 085	45° bend
	7 716 191 090	Flashing – flat roof
	7 716 191 091	Flashing – pitched roof

*Dimensions when fitted

125mm diameter		
	7 719 002 431	Vertical 1,365mm balanced flue kit (inc. adaptor)
	7 719 003 666	Extension flue kit (960mm*)
	7 719 003 664	90° bend
	7 719 003 665	45° bend
	7 716 191 090	Flashing – flat roof
	7 716 191 091	Flashing – pitched roof

*Dimensions when fitted

The following criteria should be noted when planning the installation:

- Because the appliance operates at high efficiency, a white plume of condensation will be emitted from the terminal. Care must be taken when selecting the flue terminal position
- To achieve a maximum flue length, one of the extension flue kits will need to be cut so that the permitted maximum flue length is not exceeded
- Vertical flue options 1-4 illustrate common flue installations. Other configurations of the flue system are possible up to, and not exceeding, the stated maximum flue lengths.

Option 1: Minimum height

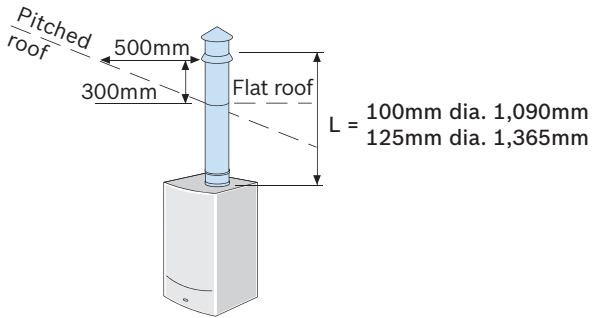

Components		
Part No. 100mm		7 719 002 430
Part No. 125mm		7 719 002 431
Maximum lengths (mm) & no. of components required		
Greenstar 30CDi Classic System		
100mm	1,090	1
125mm	1,365	1
Greenstar 35CDi Classic System		
100mm	1,090	1
125mm	1,365	1
Greenstar 12i-24i System		
100mm	1,090	1
125mm	1,365	1
Greenstar 27i & 30i System		
100mm	1,090	1
125mm	1,365	1

Option 2: Vertical balanced flue system maximum height

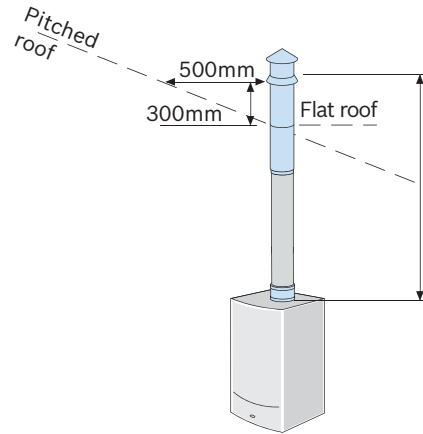

Components			
Part No. 100mm		7 719 002 430	7 716 191 083
Part No. 125mm		7 719 002 431	7 719 003 666
Maximum lengths (mm) & no. of components required			
Greenstar 30CDi Classic System			
100mm	9,400	1	up to 9
125mm	18,500	1	up to 18
Greenstar 35CDi Classic System			
100mm	8,000	1	up to 8
125mm	16,000	1	up to 16
Greenstar 12i-24i System			
100mm	6,400	1	up to 6
125mm	15,000	1	up to 14
Greenstar 27i & 30i System			
100mm	6,000	1	up to 5
125mm	15,000	1	up to 14

Note: The 100mm dia. short flue extension (Part No. 7 716 191 133) and 100mm dia. 2m flue extension (Part No. 7 716 191 172) may be used as an alternative to the standard extension as required up to the maximum flue lengths stated.

Note: The maximum flue length must be reduced by the following amounts for each bend used.

	45° bend	90° bend
Greenstar CDi Classic System 60/100mm flues	750mm	1,500mm
Greenstar CDi Classic System 80/125mm flues	1,000mm	2,000mm
Greenstar i System – all size flues	1,000mm	2,000mm

Option 3: Vertical balanced flue system with two 45° bends

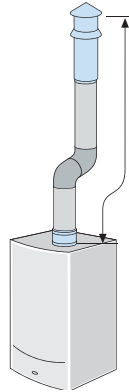

Components			
Part No. 100mm	7 719 002 430	7 716 191 083	7 716 191 085
Part No. 125mm	7 719 002 431	7 719 003 666	7 719 003 665
Maximum lengths (mm) & no. of components required			
Greenstar 30CDi Classic System			
100mm	7,900	1	up to 8
125mm	16,500	1	up to 16
Greenstar 35CDi Classic System			
100mm	6,500	1	up to 6
125mm	14,000	1	up to 14
Greenstar 12i-24i System			
100mm	4,400	1	up to 4
125mm	13,000	1	up to 13
Greenstar 27i & 30i System			
100mm	4,000	1	up to 3
125mm	13,000	1	up to 12

Note: The 100mm dia. short flue extension (Part No. 7 716 191 133) and 100mm dia. 2m flue extension (Part No. 7 716 191 172) may be used as an alternative to the standard extension as required up to the maximum flue lengths stated.

Option 4: Vertical balanced flue system with two 90° bends

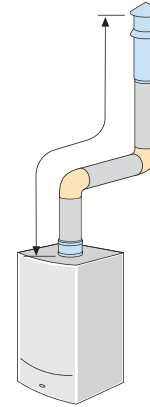

Components			
Part No. 100mm	7 719 002 430	7 716 191 083	7 716 191 084
Part No. 125mm	7 719 002 431	7 719 003 666	7 719 003 664
Maximum lengths (mm) & no. of components required			
Greenstar 30CDi Classic System			
100mm	6,400	1	up to 6
125mm	14,500	1	up to 14
Greenstar 35CDi Classic System			
100mm	5,000	1	up to 5
125mm	12,000	1	up to 12
Greenstar 12i-24i System			
100mm	2,400	1	up to 2
125mm	11,000	1	up to 11
Greenstar 27i & 30i System			
100mm	2,000	1	1
125mm	11,000	1	up to 10

Note: The maximum flue length must be reduced by the following amounts for each bend used.

	45° bend	90° bend
Greenstar CDi Classic System 60/100mm flues	750mm	1,500mm
Greenstar CDi Classic System 80/125mm flues	1,000mm	2,000mm
Greenstar i System – all size flues	1,000mm	2,000mm

Plume management terminal positioning

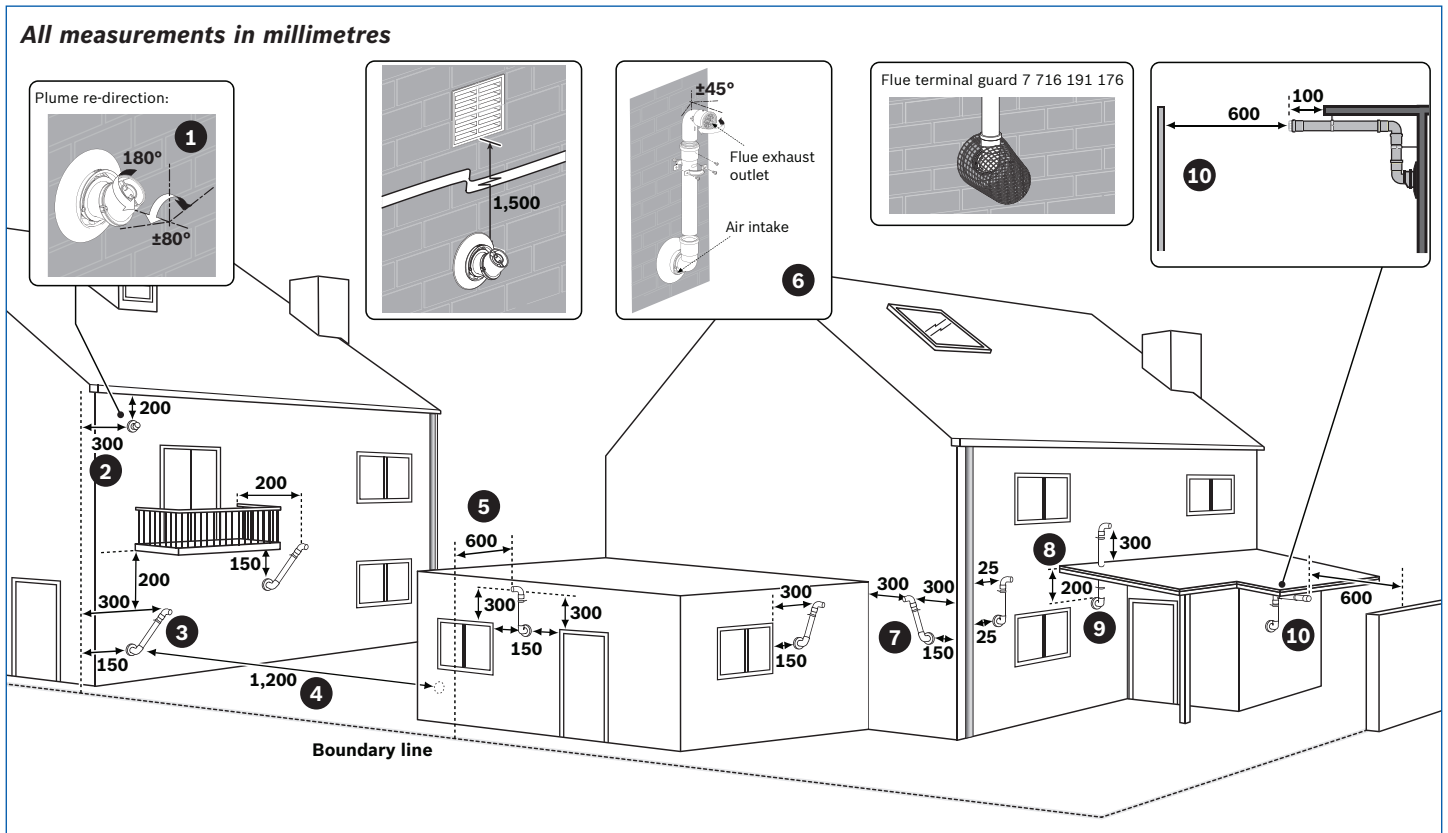

Note

- All measurements are the minimum clearances required
- Refer to pages 38-39 for all concentric flue terminal positions unless the flue position is specified on the figure above “Plume terminal positions”
- Terminals must be positioned so as to avoid combustion products entering the building
- Support the flue at approximately one metre intervals and at a change of direction, use suitable brackets and fittings.

Key to illustration

1. This feature allows some basic plume re-direction options on a standard telescopic horizontal flue terminal. 300mm minimum clearances to an opening, e.g. window. However the minimum clearances to an opening in the direction that the plume management is facing, must be increased to 1,500mm. Where the flue is less than 150mm to a drainpipe, and plume re-direction is used, the deflector should not be directed towards the drainpipe.
2. 300mm adjacent to a boundary line.
3. Plume Management Kit air intake can be reduced to 150mm providing the flue exhaust outlet is no less than 300mm adjacent to a boundary line.
4. 1,200mm between terminals facing each other.
5. 600mm distance to a boundary line, unless it will cause a nuisance. BS 5440:Part 1 recommends that care is taken when siting terminal in relation to boundary lines.

6. Using a Plume Management Kit, the air intake measurement can be reduced to 150mm providing the flue exhaust outlet has a 300mm clearance. Plume kits running horizontally must have a 10° fall back to the boiler for proper disposal of condensate. For details on specific lengths see relevant boiler Technical & Specification information.
7. Internal/external corners. The air intake clearance can be reduced to 150mm providing the flue exhaust outlet has a 300mm clearance.
8. Clearances no less than 200mm from the lowest point of the balcony or overhang.
9. 1,200mm from an opening in a car port on the same wall e.g. door or window leading into the dwelling.
10. 600mm distance to a surface facing a terminal, unless it will cause a nuisance. BS 5440: Part 1 recommends that care is taken when siting terminals in relation to surfaces facing a terminal.

- Installations in car ports are not recommended
- The flue cannot be lower than 1,000mm from the top of a light well due to the build up of combustion products
- Dimensions from a flue terminal to a fanned air inlet to be determined by the ventilation equipment manufacturer.

Plume management system options

Plume management system

60mm dia. plume management kit

- 1 x terminal bend
- 1 x extension 500mm
- 1 x outlet assembly
- 1 x clamp pack

Part No. 7 716 191 086

Accessories



Components	Part No.	Description
60mm diameter		
	7 716 191 086	Plume management kit
	7 716 191 087	Extension (1,000mm)
	7 716 191 088	90° bend
	7 716 191 089	45° bend (pair)
	7 716 191 176	Plume management terminal guard round

Standard plume management system

The flue terminal outlet has built-in stops which limits the rotation for horizontal fluing, allowing the condensate to run back into the boiler for safe disposal. Do not attempt to force beyond the limit stops.

All plume management sections must rise by at least 173mm per metre (10°) from the terminal to ensure that condensate flows back into the boiler.

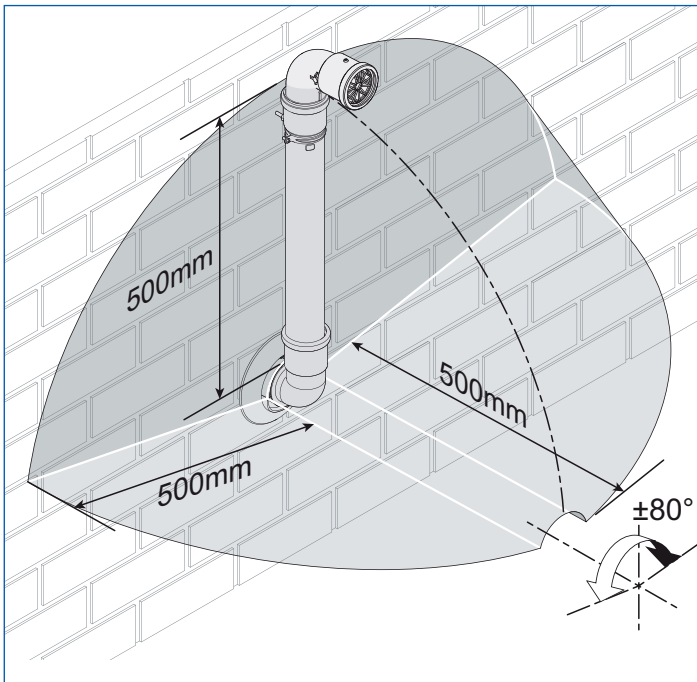

Terminal exclusion zone

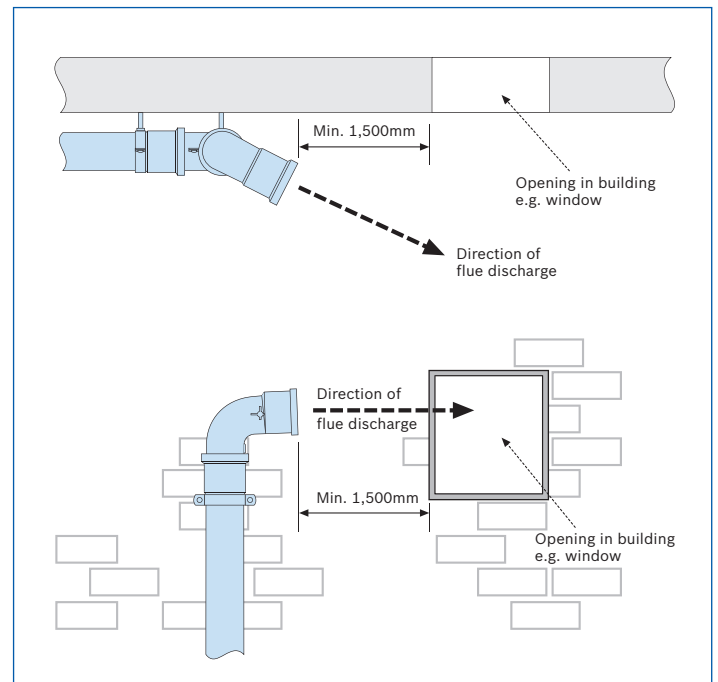

Re-directing flue discharge from a 60mm dia. plume management outlet

For Greenstar CDi Classic System boilers, the 100mm dia. internal flue length is immediately reduced by 2,000mm when the minimum plume management of 500mm is used.

For the Greenstar 27i & 30i System boilers, the 100mm dia. internal flue is immediately reduced by 1,000mm when the minimum plume management of 500mm is used.

Greenstar 12i-24i System boilers are able to use the maximum 100mm dia. internal flue length of 4,600mm regardless of the amount of plume management selected.

External plume management bends still need to be allowed for. For more information, see below.

Furthermore, for both the Greenstar CDi Classic System, and 27i & 30i System boilers, the internal flue length must be reduced by 700mm for every additional 1,000mm of plume management, refer to the table below.

60mm dia. plume management system

To ensure that the maximum total straight flue length along the plume management route is not exceeded, the following should be added to dimension (M):

- 1,500mm for each extra 90° bend
- 750mm for each extra 45° bend

For plume management options with 60mm dia. extensions, please refer to page 49.

The effective 100mm dia. internal flue length can be determined by adding together all the straight flue lengths and the effective lengths of the bends used. Allowances for 90° and 45° bends are detailed on pages 41-42.

Condensfit II™ telescopic flue and plume management system measuring

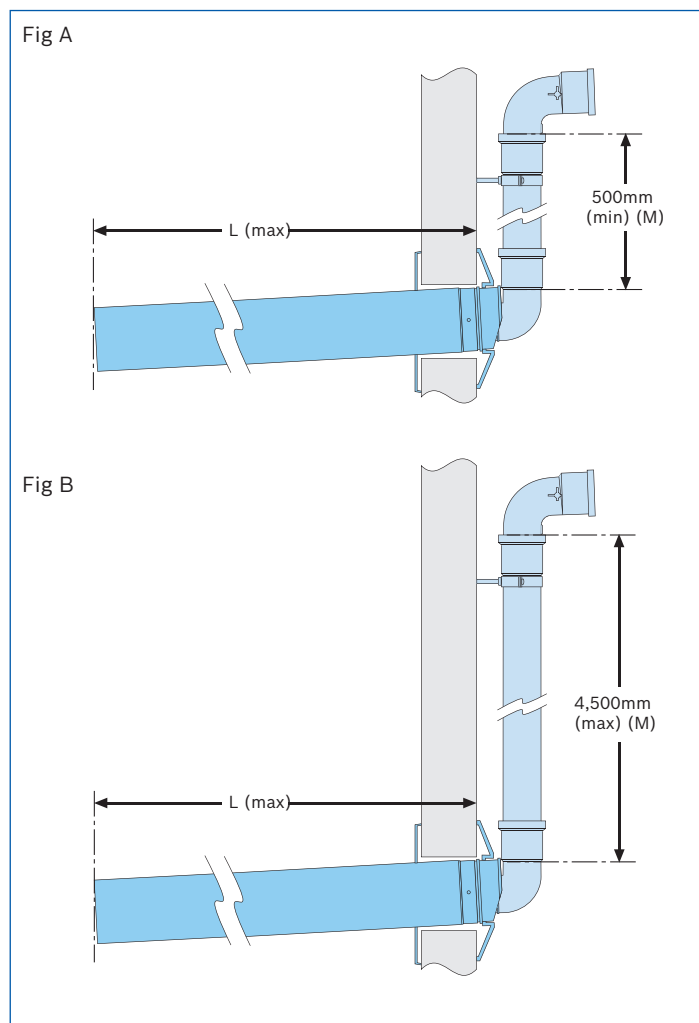

Effective straight flue lengths for telescopic flue with plume management

Boiler	Fig. A Maximum straight flue length (L) with minimum plume management length 500mm (M)	Fig. B Maximum straight flue length (L) with maximum plume management length 4,500mm (M)
30CDi Classic System	5,900mm	3,100mm
35CDi Classic System	5,000mm	2,200mm
12i-24i System models	4,600mm	4,600mm
27i & 30i System models	5,000mm	2,200mm

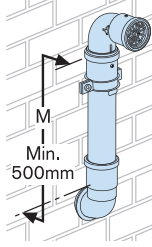

Plume management system



Components			
Part No. 60mm		7 716 191 086	
Maximum lengths (mm) & no. of components required			
Greenstar CDi Classic System* and i System series			
60mm	500	1	

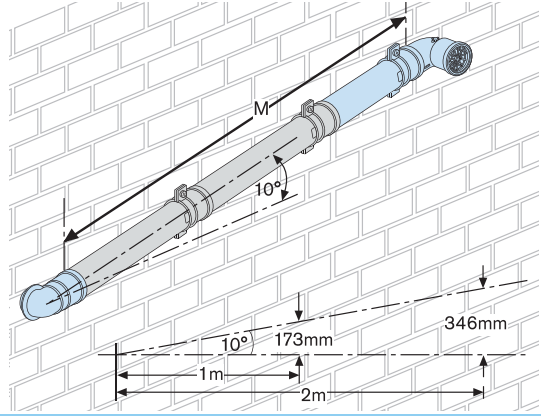

Plume management system with angled termination



Components					
Part No. 60mm		7 716 191 086		7 716 191 087	
Maximum lengths (mm) & no. of components required					
Greenstar CDi Classic System* and i System series					
60mm	4,500	1		up to 4	

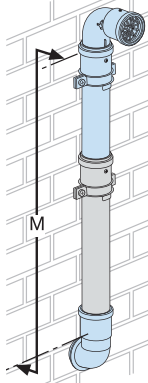

Plume management system with extensions



Components					
Part No. 60mm		7 716 191 086		7 716 191 087	
Maximum lengths (mm) & no. of components required					
Greenstar CDi Classic System* and i System series					
60mm	4,500	1		up to 4	

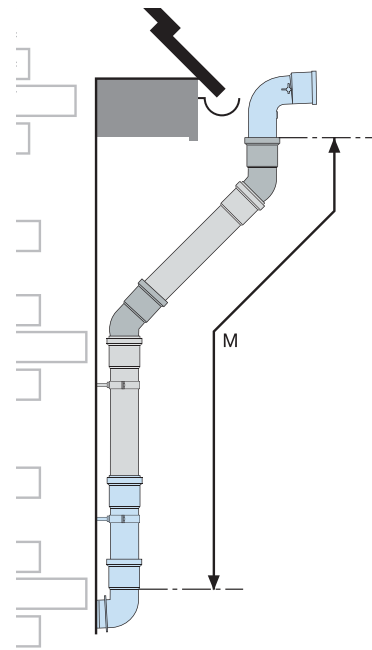

Plume management system with extensions and 45° bends

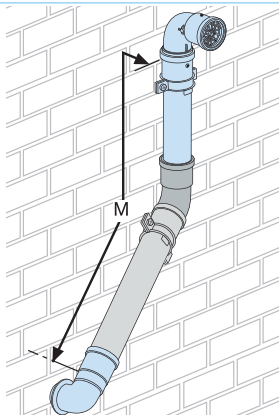

Components							
Part No. 60mm		7 716 191 086		7 716 191 087		7 716 191 089	
Maximum lengths (mm) & no. of components required							
Greenstar CDi Classic System* and i System series							
60mm	3,000	1		up to 3		2	

Plume management system with extensions and 45° bend



Components							
Part No. 60mm		7 716 191 086		7 716 191 087		7 716 191 089	
Maximum lengths (mm) & no. of components required							
Greenstar CDi Classic System* and i System series							
60mm	3,750	1		up to 4		1	

***NOTE: For CDi Classic System and i System (27 and 30kW) you must refer to the table on page 48 to calculate your horizontal flue lengths and plume management lengths.**

Greenstar system boiler range accessories

Comfort plug-in twin channel programmer



**Worcester Part No.
7 733 600 003**

Comfort I RF wireless room thermostat and plug-in twin channel programmer



**Worcester Part No.
7 733 600 001**

Comfort II RF wireless programmable room thermostat and plug-in RF receiver



**Worcester Part No.
7 733 600 002**

Intelligent system package*



**Worcester Part No.
7 719 002 824**

FR10 intelligent room thermostat



**Worcester Part No.
7 716 192 065**

FR110 programmable room thermostat



**Worcester Part No.
7 716 192 066**

FW100 weather compensation controller



**Worcester Part No.
7 716 192 067**

ISM1 intelligent solar module



**Worcester Part No.
7 716 192 068**

Wave



**Worcester Part No.
7 716 192 072**

RS telescopic flue kit (100mm dia.)



**Worcester Part No.
7 716 191 082**

Long telescopic flue kit (100mm dia.)



**Worcester Part No.
7 716 191 171**

Standard telescopic horizontal flue kit (125mm dia.)



**Worcester Part No.
7 719 003 702**

Vertical BF kit (100mm dia.)



**Worcester Part No.
7 719 002 430**

Vertical BF kit (125mm dia.)



**Worcester Part No.
7 719 002 431**

1,000mm extension kit (100mm dia.)



**Worcester Part No.
7 716 191 083**

2m flue extension (100mm dia.)



**Worcester Part No.
7 716 191 172**

**Short flue extension
220mm (100mm dia.)**



**Worcester Part No.
7 716 191 133**

**1,000mm extension
(125mm dia.)**



**Worcester Part No.
7 719 003 666**

**45° bend
(100mm dia.)**



**Worcester Part No.
7 716 191 085**

**45° bend
(125mm dia.)**



**Worcester Part No.
7 719 003 665**

**90° bend
(100mm dia.)**



**Worcester Part No.
7 716 191 084**

**90° bend
(125mm dia.)**



**Worcester Part No.
7 719 003 664**

**High level horizontal
flue adaptor (100mm dia.)**



**Worcester Part No.
7 719 002 432**

**High level horizontal
flue adaptor (125mm dia.)**



**Worcester Part No.
7 719 002 433**

**Support bracket kit
(100mm dia.)**



**Worcester Part No.
7 716 191 092**

**Support bracket kit
(125mm dia.)**



**Worcester Part No.
7 716 191 174**

**Support bracket kit
6 pack (100mm dia.)**

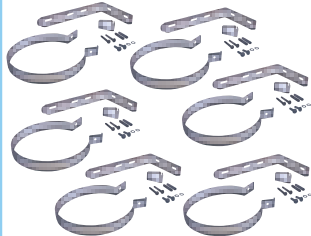

**Worcester Part No.
7 716 191 173**

**Support bracket kit-
27i & 30i System only
(100mm dia.)**



**Worcester Part No.
7 716 191 177**

**Support bracket kit-
27i & 30i System only
(125mm dia.)**



**Worcester Part No.
7 716 191 179**

**Support bracket kit
6 pack - 27i & 30i System
only (100mm dia.)**



**Worcester Part No.
7 716 191 178**

**Optional 30kW CDi Classic
System diverter valve kit**













**Worcester Part No.
7 719 002 746**

**Optional 35kW CDi Classic
System diverter valve kit**

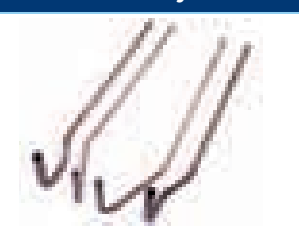

**Worcester Part No.
7 738 112 011**

Greenstar system boiler range accessories

<p>Optional 12kW i System diverter valve kit</p>  <p>Worcester Part No. 7 716 192 566</p>	<p>Optional 15kW i System diverter valve kit</p>  <p>Worcester Part No. 7 716 192 567</p>	<p>Optional 18kW i System diverter valve kit</p>  <p>Worcester Part No. 7 716 192 568</p>	<p>Optional 24kW i System diverter valve kit</p>  <p>Worcester Part No. 7 716 192 409</p>
<p>Optional 27kW i System diverter valve kit</p>  <p>Worcester Part No. 7 716 192 758</p>	<p>Optional 30kW i System diverter valve kit</p>  <p>Worcester Part No. 7 716 192 759</p>	<p>Vertical pre-piping assembly for CDI Classic System</p>  <p>Worcester Part No. 7 716 192 651</p>	<p>Vertical pre-piping assembly for 12, 15, 18 & 24i System</p>  <p>Worcester Part No. 7 716 192 650</p>
<p>Vertical pre-piping assembly for 27i & 30i System*</p>  <p>Worcester Part No. 7 716 192 713</p>	<p>Earth bonding strip#</p>  <p>Worcester Part No. 7 716 192 686</p>	<p>Below boiler pipe cover</p>  <p>Worcester Part No. 7 716 192 608</p>	<p>Plume management kit (60mm dia.)</p>  <p>Worcester Part No. 7 716 191 086</p>
<p>Extension (60mm dia., 1,000mm)</p>  <p>Worcester Part No. 7 716 191 087</p>	<p>90° bend (60mm dia.)</p>  <p>Worcester Part No. 7 716 191 088</p>	<p>45° bend (60mm dia.)</p>  <p>Worcester Part No. 7 716 191 089</p>	<p>Flat roof flashing kit (100mm & 125mm dia.)</p>  <p>Worcester Part No. 7 716 191 090</p>

**Pitched roof flashing kit
(100mm & 125mm dia.)**

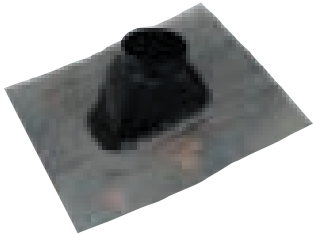

**Worcester Part No.
7 716 191 091**

**Plume management
terminal guard round
(60mm dia.)**

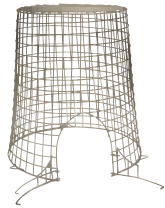

**Worcester Part No.
7 716 191 176**

Greenstore SC Cylinders



Worcester Part No.	
SC-90	7 716 842 027
SC-120	7 716 842 028
SC-150	7 716 842 029
SC-180	7 716 842 030
SC-210	7 716 842 031
SC-250	7 716 842 032
SC-300	7 716 842 033

Greenstore TC Cylinders



Worcester Part No.	
TC-150	7 716 800 542
TC-180	7 716 800 543
TC-210	7 716 842 042
TC-250	7 716 842 043
TC-300	7 716 842 044

Greenstar System Filter



**Worcester Part No.
7 716 192 609**

**Worcester
CondenseSure siphon**



**Worcester Part No.
7 716 192 746**

WB3 cleaning tool



**Worcester Part No.
7 716 192 312**

WB5 cleaning tool



**Worcester Part No.
7 719 001 996**

WB7 cleaning tool



**Worcester Part No.
7 746 901 479**

Remote PRV kit**



**Worcester Part No.
7 716 161 071**

Total training experience from Land's End to John O'Groats

Worcester has always been committed to setting the industry standard for expert professional training and this is reflected in the scope and content of the courses, venues and options available.

We offer training on our entire range of domestic and commercial heating technologies as well as industry-led courses. All tuition is handled by expert heating specialists, combining classroom theory with, practical hands-on experience. Keep up-to-date with legislation and experience hands-on-training with our new technologies.

To increase your skills, expertise and value in the market place, trust Worcester's unique and proven total training concept.

Training centres throughout the UK

Worcester

Worcester's award-winning, state-of-the-art Training Academy is an innovative and spacious high tech training arena at our headquarters in Worcester. Facilities include open-plan domestic training areas with life-size single-storey brick buildings. Here installers can get to grips with Greenskies solar thermal systems working with Greenstar gas appliances, clearly demonstrating the importance of system design and operation.

Wakefield

Opened in Summer 2013, the Wakefield Training and Assessment Academy boasts a large gas laboratory which features our entire range of Greenstar gas-fired appliances, a flushing area, wet and dry boilers and a light commercial area with a cascade of Worcester GB162 boilers. It also contains a heat pump room with a full range of Greenstore ground source, Greensource air source and Greenstar Plus hybrid heat pumps with a courtyard for all external components. There is a solar room with fully working components from our entire Greenskies solar range and a pitched roof for practical training, as well as a large commercial training room.

West Thurrock and Clay Cross

Further academies are located at West Thurrock in Essex and Clay Cross in Derbyshire, both of which offer a comprehensive choice of courses.

College-linked Learning

As well as offering training at our own centres, Worcester has established close partnerships with many colleges around the UK, equipping them with our latest products.

Worcester has worked closely with leading colleges and independent training centres for more than 20 years – a successful enterprise which in 2007 was enhanced further with the launch of the College Links Learning Scheme.

Mobile training

We can also bring training to you. We have mobile vehicles fully equipped with operational Greenstar gas-fired boilers, dry strip-down models and even a Greensource air to air heat pump. Our 7.5 tonne mobile oil vehicle is also available for hands-on oil product training and OFTEC assessments.

Call now for more information 0330 123 0166.



Gas-fired product courses

As a market leader in gas-fired condensing boilers, we aim to ensure the highest levels of competence and expertise in the installation of all Worcester Greenstar gas-fired products. We run intensive training courses for installers, commissioning engineers and operatives involved with servicing and fault finding.

Our comprehensive gas-fired condensing boiler training courses include product overview, inspection and cleaning of components, CO and CO₂ analysis of flue gas, removal of compact hydraulics, service mode functions and fault finding on 'live and demo' appliances.

Gas-fired condensing boiler courses

- **Greenstar CDi Classic gas-fired condensing combi boilers.**
- **Greenstar CDi Compact and Greenstar Si Compact gas-fired condensing combi boilers.**
- **Greenstar i Junior gas-fired condensing combi boilers.**
- **Greenstar system & regular gas-fired condensing boilers.**
- **Greenstar Highflow CDi & FS CDi Regular floor standing gas-fired condensing combi and regular boilers.**
- **Greenstar Controls** (covers MT10, MT10RF, NEW Greenstar Comfort range, NEW Wave internet connected room thermostat, FR10, FR110, FW100, and ISM1).

	Greenstar Overview	CDi Classic	CDi Compact & Si Compact	i Junior	System & Regular	Highflow CDi & FS CDi Regular	Controls
Duration	1 Day	1 Day	1 Day	1 Day	1 Day	1 Day	1 Day
Cost	Free*	Free*	Free*	Free*	Free*	Free*	Free*
Training course covers							
Specification	✓	✓	✓	✓	✓	✓	Guide to the varied range of control options that are available
Installation	✓	✓	✓	✓	✓	✓	
Commissioning	✓	✓	✓	✓	✓	✓	
Servicing	✓	✓	✓	✓	✓	✓	
Maintenance	✓	✓	✓	✓	✓	✓	
Course locations							
Worcester	✓	✓	✓	✓	✓	✓	✓
Clay Cross	✗	✗	✗	✗	✗	✗	✓
Wakefield	✓	✓	✓	✓	✓	✓	✓
West Thurrock	✓	✓	✓	✓	✓	✗	✗
College Links†	✓	✓	✓	✓	✓	✗	✓
Mobile†	✓	✓	✓	✓	✗	✗	✓

*A holding fee of £65 applies to free courses and is refunded on attendance of the course. If a booking is cancelled more than 10 working days before the course date, the fee will be fully refunded. The fee is non-refundable if a cancellation is made less than 10 working days before the course date.
 †Please contact Worcester Training for specific colleges and mobile dates.



Additional product and industry training courses

The diversity of products in today's heating industry gives you the opportunity to expand your expertise, whilst offering more choice to your customers. Worcester provides comprehensive training from all its academies on its entire range of technologies. Call us on **0330 123 0166** to order a full course training brochure or to book yourself onto a training course, alternatively, you can visit www.worcester-bosch.co.uk/training

Oil-fired product courses

- Greenstar Danesmoor & Heatslave II high efficiency condensing oil-fired boilers.
- Oil advanced fault finding.
- OFTEC 50.
- OFTEC 101/105e, OFTEC 600a and OFTEC 101/105e/600a.

Renewable product courses

- Renewables overview.
- Greenskies solar.
- Greenskies advanced solar.
- Introduction to heat pumps.
- Greenstore LECP ground source heat pumps.
- Greensource air to air heat pumps.
- Greensource air to water heat pumps.
- Greensource split air to water heat pumps.

Worcester commercial product courses

- Greenspring CWi47 water heater.
- GB162 overview.
- GB162 domestic.
- GB162 commercial.
- Greenstar Heat Distribution Unit.
- Commercial ACS training and assessment – CODNCO1.

Bosch commercial product courses

- GB312 & GB402 overview.
- Solar thermal product overview.
- GWPL Gas Absorption Heat Pumps overview.
- CHP overview.
- Commercial controls overview.

Industry focused courses

- Hot water systems & safety.
- Chemical water treatment.
- Construction skills F-Gas training/assessment certification.
- IDHEE domestic heating design.
- Domestic ACS training and assessment – reassessment. CCN1 + 3 appliances.
- QCF Level 3 Award
 - Air source and ground source heat pumps.
 - Air to water and split air to water heat pumps.
 - Solar thermal.
- MCS Made Easy.
- Green Deal.
- LPG Changeover.
- WRAS Water Regulations.



A complete after-sales service

As part of the worldwide Bosch Group, Worcester strives to maintain the highest possible standards of after-sales care.

Worcester Contact Centre

Should you require support, our award winning Contact Centre team, based at our head office in Worcester, are ready to take your calls. Whatever your query our contact centre operators along with our nationwide team of engineers are ready to help you.

Tel: 0330 123 9559

Opening times

Monday – Friday: 7.00am – 8.00pm

Saturday: 8.00am – 5.00pm

Sunday: 9.00am – 12 noon

Bank Holidays: 8.00am – 4.30pm



Spares

Genuine replacement parts for all supported Worcester products are readily available from stock, or on a next day delivery basis. Visit www.worcester-bosch.co.uk/spares to find your local stockist.

Customer Technical Support

The Worcester Technical Helpline is a dedicated phone line – committed to providing a comprehensive service to complement the brand name and quality of our products. Our experienced team of technical experts provides answers to queries of a technical nature across the entire Worcester range.

Technical Support

Tel: 0330 123 3366

Fax: 01905 752 741

Email: technical-advice@uk.bosch.com

Opening times

Monday – Friday: 7.00am – 8.00pm

Saturday: 8.30am – 4.00pm

Bank Holidays: 8.00am – 4.30pm

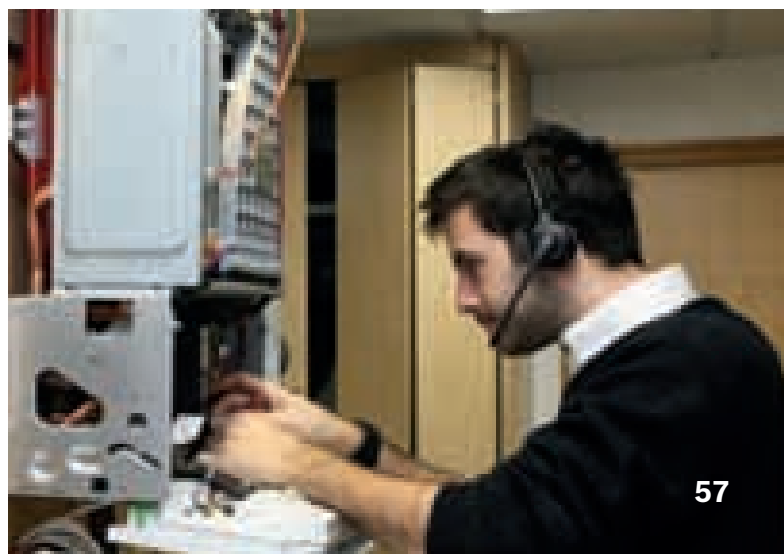
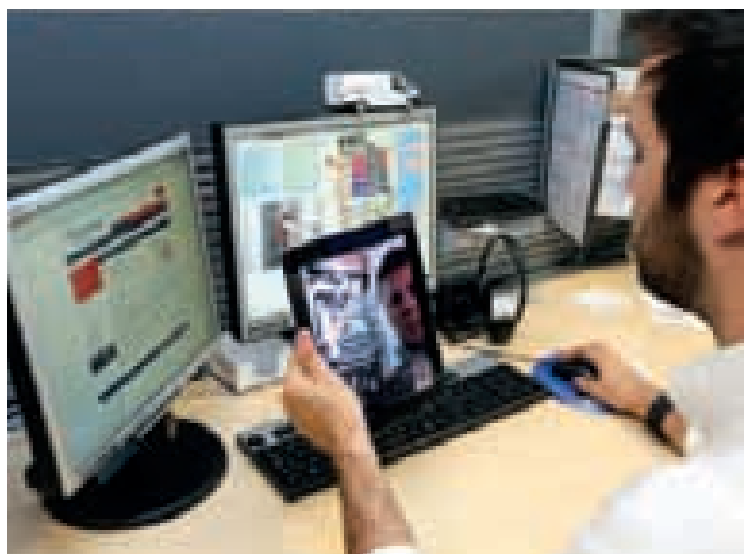

Notes

Useful numbers

Sales

Tel: 0330 123 9669
sales.mailbox@uk.bosch.com

Spare Parts

Tel: 0330 123 9779
spares.mailbox@uk.bosch.com

Technical Helpline (Pre & Post Sales)

Tel: 0330 123 3366
technical-advice@uk.bosch.com

Renewables Technical Helpline

Email: renewable-advice@uk.bosch.com
or telephone 0330 123 9229

Training

Tel: 0330 123 0166
training@uk.bosch.com

Literature

Email: brochure-request@uk.bosch.com
or download instantly from our website
or telephone 0330 123 9119

Customer Service

Engineer Appointments

Email: service-appointment@uk.bosch.com
or telephone 0330 123 9339

Service Enquiries

Email: service-enquiries@uk.bosch.com
or telephone 0330 123 9559

Guarantee Registration

To register your Worcester guarantee,
please visit our website
www.worcester-bosch.co.uk/registration
or telephone 0330 123 2552

Calls to 03 numbers cost no more than a national rate call to an 01 or 02 number and must count towards any inclusive minutes in the same way as 01 and 02 calls.
These rules apply to calls from any type of line, including mobile, BT, other fixed phone line or payphone. Calls from mobiles and some other networks may vary.
Calls to and from Bosch Thermotechnology Ltd may be recorded for training and quality assurance purposes.

worcester-bosch.co.uk



Worcester, Bosch Group is a brand name of Bosch Thermotechnology Ltd.

This leaflet is accurate at the date of printing, but may be superseded and should be disregarded if specification and/or appearances are changed in the interest of continued improvement. The statutory rights of the consumer are not affected. Apple is a trademark of Apple Inc., registered in the U.S. and other countries. App Store is a service mark of Apple Inc. Google Play and Android are trademarks of Google Inc.

Part No. 8 716 116 715 D 01/15



Worcester, Bosch Group,
Cotswold Way, Warndon,
Worcester, WR4 9SW